

Pressure Reducing Valve HON 210



PRODUCT INFORMATION

**Serving the Gas Industry
Worldwide**

Honeywell

Pressure Reducing Valve HON 210

Application, characteristics, technical data

Application

- for industrial and laboratory applications; also suitable for small flowrate regulating lines within large volume gas pressure regulating stations
- suitable for natural gas and all non-corrosive gaseous media; special version on demand

Characteristics

- only small setpoint deviations due to inlet pressure variations
- easy operation and maintenance
- electric remote control of outlet pressure as a special and optional feature
- can be provided with internal or external measuring impulse connection

TECHNICAL DATA	
max. inlet pressure P_{emax}	100 bar
pressure range W_h (see table page 3) - outlet pressure stage - intermediate pressure stage	0,020 bar to 3,5 bar 0,100 bar to 5,0 bar
valve seat diameter	6 mm
flow rate coefficient K_G (for natural gas $\rho_n = 0,83 \text{ kg/m}^3$)	18 m ³ /h
connections	screw connection without brazing with compression fitting acc. to DIN 2353 inlet pressure line for pipe outside dia. 12 mm outlet pressure line for pipe outside dia. 16 mm ext. measuring line for pipe outside dia. 12 mm
function and strength	acc. to EN 334
CE-Registration, DIN-DVGW reg. no.	approved
temperature class 2	-20°C to +60°C
weight	measuring unit MN approx. 9 kg, measuring unit MM approx. 5 kg
materials	body aluminium alloy internal parts brass, stainless steel diaphragms and gaskets NBR
filter	HON 905 (see leaflet 905.00)
special version	single stage version

TECHNICAL DATA					
intermediate pressure stage			outlet pressure control stage		
measuring unit type	pressure range W_a (bar)	spring wire-Ø (mm)	measuring unit type	pressure range W_a (bar)	spring wire-Ø (mm)
M	0.1 to 0.5	3.3	N	0.020 to 0.040	2.5
				0.030 to 0.060	3.0
0.050 to 0.120	3.5				
0.080 to 0.200	4.0				
0.150 to 0.500	5.0				
	0.5 to 5.0	4.7	M	0.3 to 1.5	3.3
				1.0 to 2.5	4.0
				2.0 to 3.5	4.5

Remark:

For $q_n > 9 \cdot p_a$ a separate outlet pressure measuring impulse line has to be connected to the pipe section expansion downstream of the regulator (external measuring impulse connection)

Flowrate:

A supercritical pressure drop is reached at

$$\frac{p_a}{p_e} \leq 0,5$$

flowrate calculation at supercritical pressure drop:

$$q_n = KG \cdot \frac{p_z}{2} \quad (\text{m}^3/\text{h})$$

A subcritical pressure drop is reached at

$$\frac{p_a}{p_e} > 0,5$$

flowrate calculation at subcritical pressure drop:

$$q_n = KG \cdot \sqrt{p_a (p_z - p_a)} \quad (\text{m}^3/\text{h})$$

Attention! Pressures for the above formulas to be inserted in absolute values (bar absolute).

p_z = chosen intermediate pressure

Pressure Reducing Valve HON 210

Design and operation

4

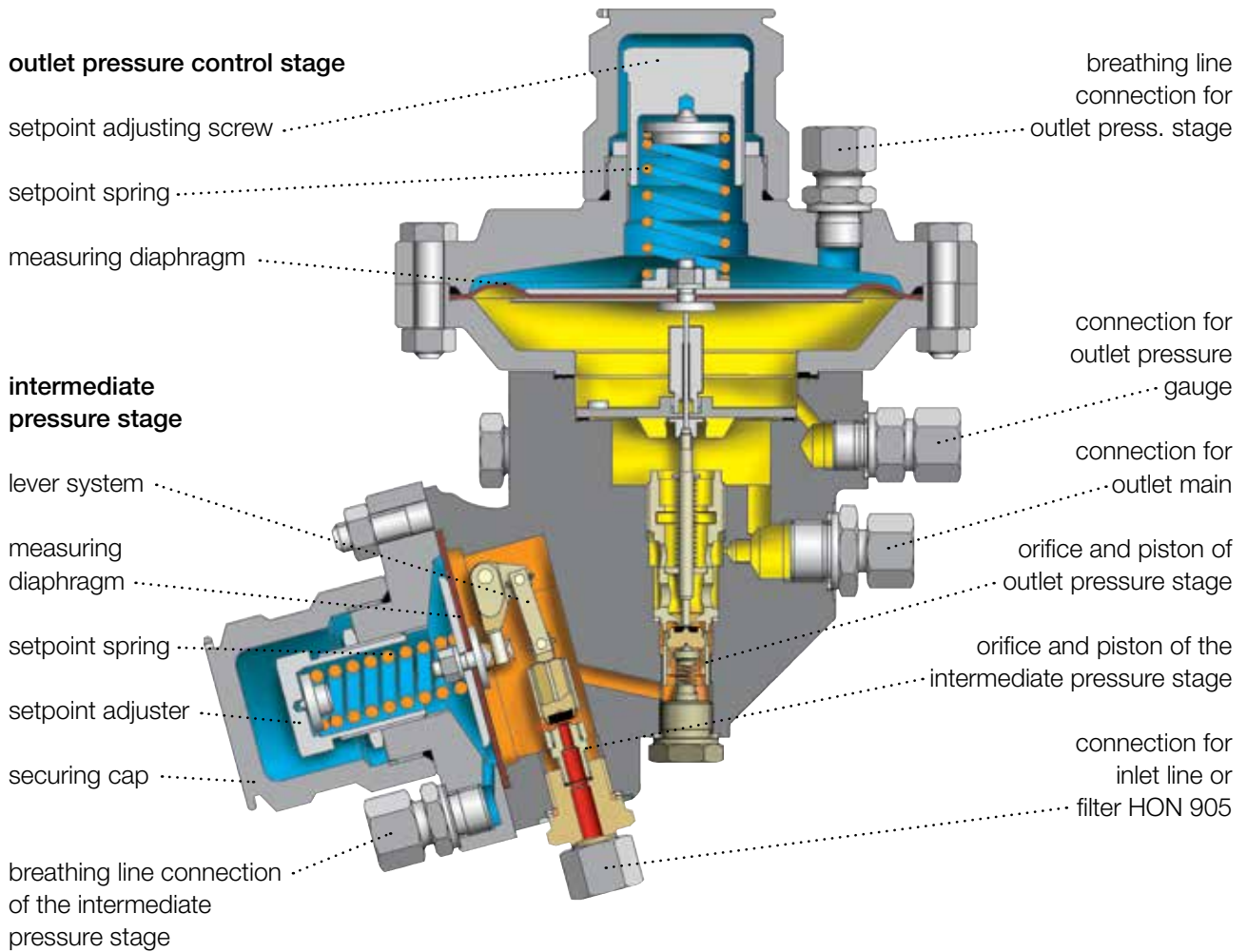

This two-stage regulator was designed to keep the outlet pressure of a gaseous medium constant in the main and independent of disturbing influences like inlet pressure or flowrate changes. Due to the intermediate pressure unit integrated into this spring-loaded regulator the negative influence of inlet pressure changes upon the regulating accuracy is reduced to a negligible minimum and practically excluded.

This two-stage regulator was designed to keep the outlet pressure of a gaseous medium constant in the main and independent of disturbing influences like inlet pressure or flowrate changes. Due to the intermediate pressure unit integrated into this spring-loaded regulator the negative influence of inlet pressure changes upon the regulating accuracy is reduced to a negligible minimum and practically excluded.

This two-stage regulator was designed to keep the outlet pressure of a gaseous medium constant in the main and independent of disturbing influences like inlet pressure or flowrate changes. Due to the intermediate pressure unit integrated into this spring-loaded regulator the negative influence of inlet pressure changes upon the regulating accuracy is reduced to a negligible minimum and practically excluded.

Pressure Reducing Valve HON 210

Dimensions

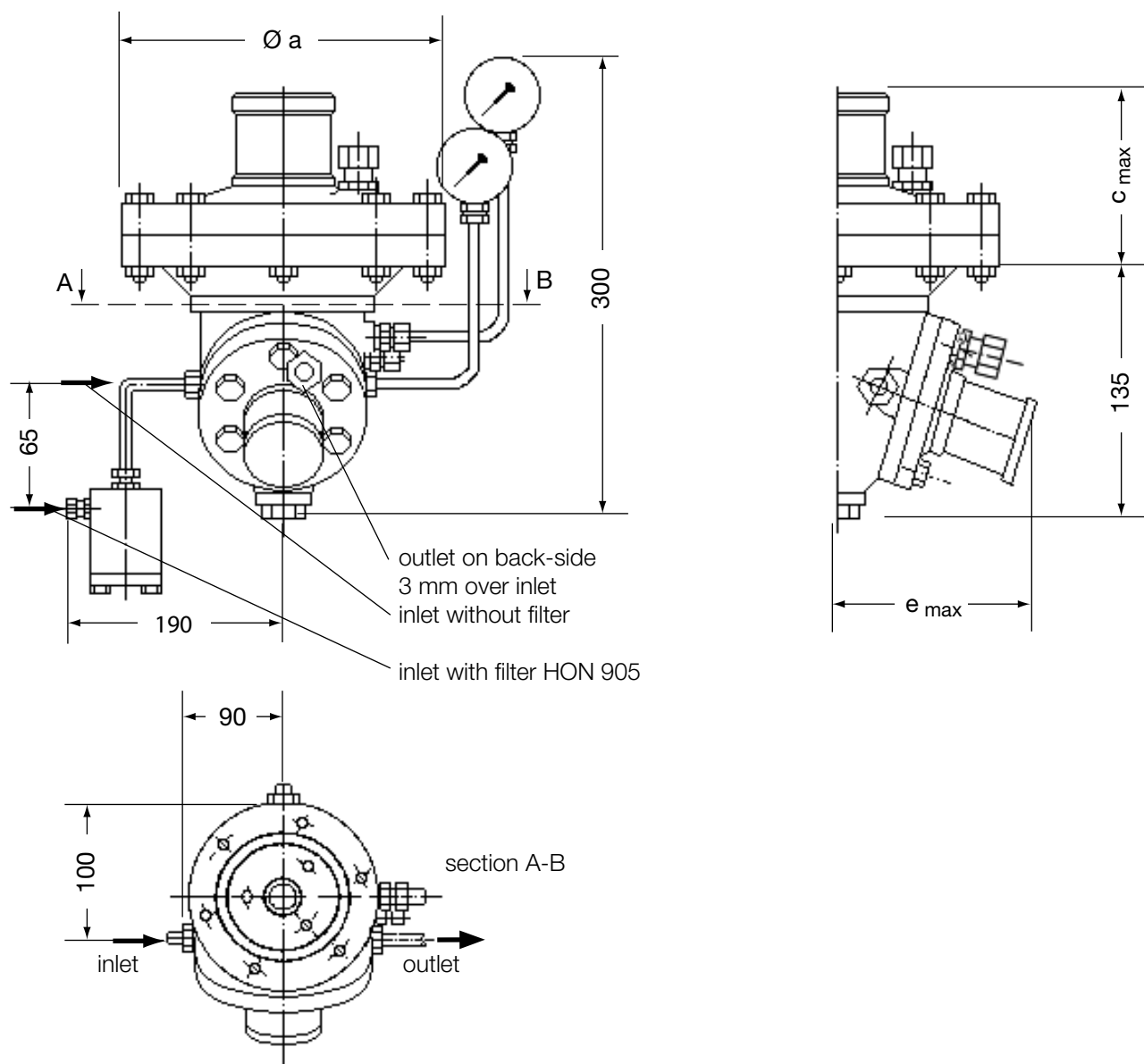

DIMENSIONS IN MM			
measuring unit	$\varnothing a$	c_{max}	e_{max}
N	200	95	130
M	125	70	

example:

HON 210 - 12 / 16 - M / N - 1 - 905 - So

TYPE DESCRIPTION	
intermediate pressure stage	
measuring unit M	M
outlet pressure control stage	
measuring unit N	N
spec. outlet pressure range W_a (bar)	0.020 to 0.040 0.030 to 0.060 0.050 to 0.120 0.080 to 0.200 0.150 to 0.500
measuring unit M	M
spec. outlet pressure range W_a (bar)	0.3 to 1.5 1.0 to 2.5 2.0 to 3.5
measuring impulse connection	
internal connection	1
external connection	2
filter	
without filter in inlet line	0
with filter HON 905 in inlet line	905
special feature (to be specified in detail)	So



For More Information

To learn more about Honeywell's
Advanced Gas Solutions, visit
www.honeywellprocess.com or contact
your Honeywell account manager

GERMANY**Honeywell Process Solutions**

Honeywell Gas Technologies GmbH
Osterholzstrasse 45
34123 Kassel, Deutschland
Tel: +49 (0)561 5007-0
Fax: +49 (0)561 5007-107

HON 210.00
2017-01
© 2017 Honeywell International Inc.

Honeywell