

# Flow Control Valve HON 530-E-WG



PRODUCT INFORMATION

**Serving the Gas Industry  
Worldwide**

**Honeywell**

## HON 530-E-WG flow control valve

Applications, characteristics, technical specifications

### Applications

- For feeding gas into and/or withdrawing gas from gas storage facilities and important gas mains
- For all tasks in connection with optimising gas supply
- For all tasks of flow-rate or gas pressure control with slow valve adjustment
- Suitable for gases according to DVGW Worksheet G 260 and neutral, non-aggressive gases, for other gases on enquiry
- Bi-directional operation

2

### Characteristics

- Main valve with electric actuator
- In-line flow guarantees very high flow rates
- Valve sleeve with full compensation of static inlet and outlet pressures
- Noise attenuation devices as a standard feature
- Linear performance curve with equal percentages – or customized according to operating conditions
- In case of a current failure → valve stays put in last position (function: fail position (FP))
- Electric actuator for three-step control with PI behaviour in combination with electric pilots
- Frequency-dependent valve control speeds are possible – setting by means of a frequency converter depending on operating conditions
- Explosion-proof design

TECHNICAL DATA					
Actuator unit					
Max. admissible pressure PS	Depending on flange pressure stage up to 100 bar				
Max. operating pressure pmax; bi-directional operation possible	Depending on flange pressure stage up to 100 bar				
	Inlet	Outlet	Valve seat	Valve stroke (mm)	Valve travel time (s)
Pipe size DN* Valve seat diameter and stroke:	200	200	200	114	57
		250			
		300			
	250	250	200		
		300			
	300	300	200		
	300	300	300		
400	400	400	189	95	
Type of connection	DIN flange PN 40 and flange according to class 600 ANSI 16.5				
Temperature range class 2 (DIN) EN 334	Ambient and operating temperatures –20 °C to +60 °C (other temperature ranges on enquiry)				
Valve sleeve	– With full compensation of static inlet and outlet pressures – With oxide-ceramic surface coating to protect guide and sealing areas				
Bubble-tight shut off of final control element (valve seal)	By means of elastic sealing ring according to DIN EN 12266 part 2; leak rate A				
With integrated noise attenuation	Standard				

\* Other pipe sizes on enquiry

## HON 530-E-WG flow control valve

Applications, characteristics, technical specifications

3

TECHNICAL DATA		
<b>Electric variable-speed drive/electric control</b>		
Power supply	230 V/50 Hz or 400 V/50 Hz*. Other voltages and frequencies on enquiry	
Power consumption	0.5–1.5 kW – depends on pipe size	
Control	3-step control → ccw/OFF/cw	
Nominal speed $n_{50}$	Depends on valve travel time $t_f$	
Valve travel time $t_f$	Approx. 1 to 4 min. depending on type	
Stroke limiting switch; $WE_{min}/WE_{max}$	Standard for valve stroke 0–100 %	
Emergency torque limiting switch $DME_{min/max}$	Standard	
Explosion protection of variable-speed drive	II 2 G EEx de IIC T4/de IIC T3**	
Electrical control	Power supply unit	Optional use of a frequency converter is possible with standard drive systems (DREHMO)
	Control unit (automation)	PLC or micro-controller
<b>Actuator unit</b>		
Mechanical transmission of power	Via rotary drive	
Valve travel time $t_f$	Approx. 1 to 4 min. per stroke, depending on type	
Position indicator (valve stroke 0–100 %)	Remote position indicator potentiometer 5 k $\Omega$ via ex-protection isolating amplifier – also 0/4–20 mA signal at control room	
Materials	Casing	Cast steel (Honeywell standard) ***
	Internal parts of main valve	Steel, spheroidal iron, Ms, Al alloys
	Sealing rings	Rubber plastics (NBR), PTFE
Function and strength	Following DIN EN 334	
Explosion protection	All mechanical components of this device are without ignition sources. They are not subject to ATEX 95 (94/9/EC). The electrical components used with this device fulfil the ATEX requirements.	

\* Starting with DN 400: power supply 400 V only

\*\*\* –46 °C

\*\* Depends on variable speed drive

VALVE SPECIFICATIONS			
Pipe size Inlet (DN)	Pipe size Outlet (DN)	Valve seat $\varnothing$ (mm)	(Valve) flow rate coefficient $K_G^*(m^3/h)/bar$
200	200	200	30,000
	250		30,000
	300		30,000
250	250	200	30,000
	300		30,000
	400		30,000
300	300	200	30,000
300	300	300	54,000
400	400	400	90,000

\* for natural gas  $w/d = 0.64$  ( $\rho_n = 0.83 \text{ kg/m}^3$ ) and gas temperature  $t_n = 15 \text{ }^\circ\text{C}$

REGISTRATION	
CE registration according to PED	

## HON 530-E-WG flow control valve

Design and operation

### Applications

The HON 530-E-WG flow control valve has been designed for flow-rate and pressure control duties. It is deployed in conjunction with electronic flow-rate and/or pressure control loops. Target applications are conditions where large-volume gas flows must be flow-rate and/or pressure controlled even in case of smallest pressure differences. Thanks to its favourable valve travel time, this device is particularly suitable for facilities with important storage volumes.

The HON 530-E-WG may be of help e. g. for optimising efficient gas supply and feeding gas into and/or withdrawing gas from gas storage facilities and important mains.

4

### Functional description

The design of the HON 530-E-WG comprises only few parts and is easy to maintain. The final control element is based on the tested in-line flow and valve-sleeve design. The valve sleeve is designed in such a way that a complete compensation of static inlet and outlet pressures is guaranteed. The sealing ring built into the perforated expansion piece guarantees the bubble-tight shut-off of the device. The valve seat is not subject to much wear and tear due to flow during operation and should have a rather long service life.

There is an electric actuator to adjust the travel of the valve sleeve. The actuator is flange-mounted to the final control element. The drive shaft is connected directly to the rotary drive. Thanks to the variable-speed adjustment thread, the transmission system converts the rotary movement of the drive into a straight in-line travel motion of the valve sleeve and thus adjusts the opening of the valve. The valve sleeve 'floats' in the expansion piece.

The operating side may be on the left or right-hand side, at option. This flow control valve is equipped with a standard perforated expansion piece. The concepts applied here, i. e. splitting the jet via the grid plate and restricting the relief process to a limited section, reduce the noise generated up to 25 dB(A) as compared to conventional designs.

This control valve may be used as a uni-directional or as a bi-directional valve.

### Flow control valve HON 530-E-WG DN 200/200

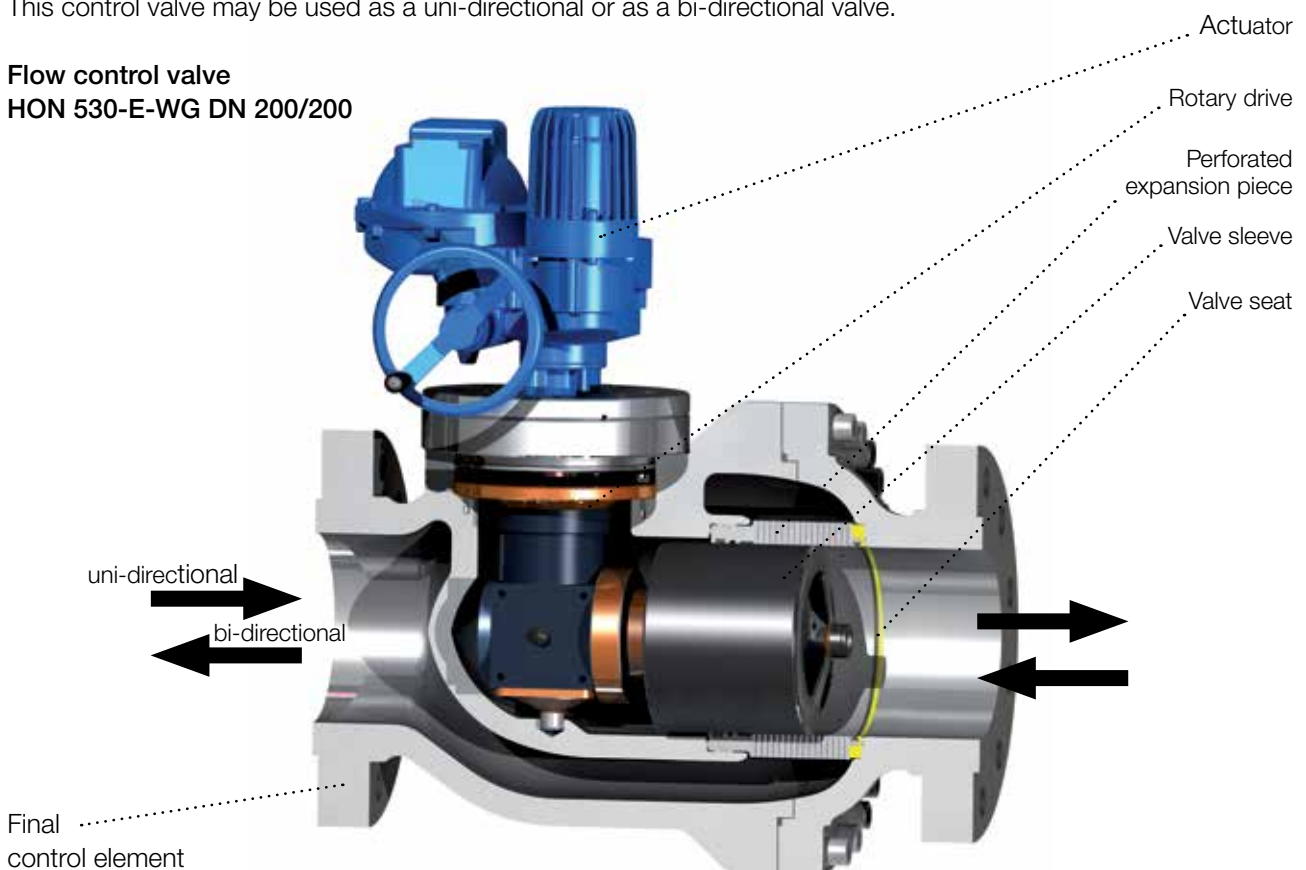

**Flow control valve  
HON 530-E-WG DN 200/300**

(picture shows  
uni-directional version)

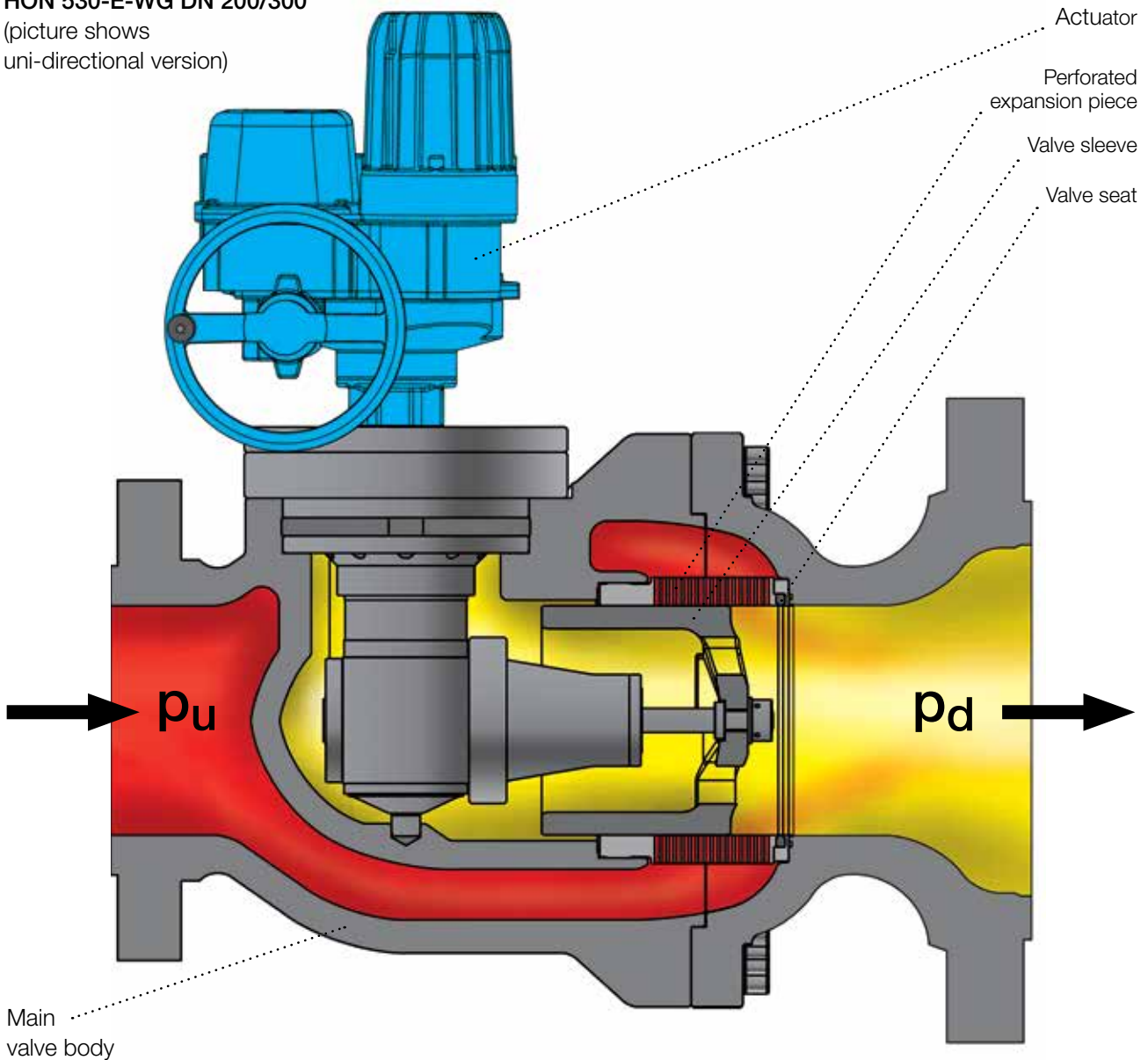

Main  
valve body

**Electric actuator**

The HON 530-E-WG flow control valve is equipped with an electric actuator. The actuator operates on a rotary drive and thus adjusts the valve opening. The (optional) frequency converter, rotary drive and inline adjustment thread together provide for a very sensitive adjustment of the valve opening and, thus, a very precise control. Available standard drives are for 230 V and 400 V. For other voltages, please enquire. The valve sleeve is constantly in a state of equal pressure. This facilitates operation at very low torques. Stroke limiting switches set a limit to the stroke of the valve. The valve opening may also be changed manually, by turning a hand wheel. The user decides whether the operator stands on the left or right-hand side of the device. Honeywell offers retrofit kits (e. g. SCS 2001) that may be installed in order to build up fully automatic flow-rate and/or pressure control systems, e. g. for storage control systems. Variable speed drives used may be of different makes and brands.

Such a system consisting of frequency converter control and Honeywell automation kits may offer significant benefits when compared to conventional types. Our experienced engineers will be glad to assist you in solving your very specific automation challenges.

## HON 530-E-WG flow control valve

Dimensions and weights

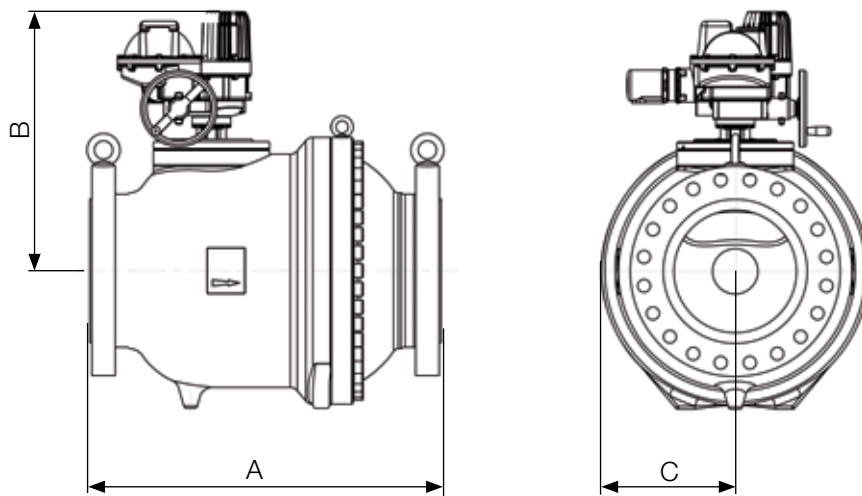

DIMENSIONS, WEIGHTS										
Nominal width	Inlet	200	200	200	250	250	250	300	300	400
	Outlet	200	250	300	250	300	400	300	300	400
Max. admissible pressure	PS = 100 bar/CLASS 600 (ANSI 16.5)									
Type of flange										
Valve seat diameter (mm)	200								300	400
A	720/700**	783	803	850	870	830	900	900	1150	
B* DREHMO (mm)	673	673	673	673	673	673	673	782	848	
C* DREHMO (mm)	353	353	353	353	353	353	353	353	437	
B* AUMA (mm)	526	526	526	526	526	543	526	602	668	
C* AUMA (mm)	265	265	280	265	280	345	280	353	437	
Weight in kg (approx.)	430/396**	491	512	525	543	600	570	1026	1780	

\* depends on drive

\*\* PN 40

Example

HON 530-E-WG - 200/300 - 200 - 1 - FU - A - So



FINAL CONTROL ELEMENT		
Pipe size DN		Valve seat in mm
Inlet	Outlet	VS
200	200	200
200	300	200
300	300	300
400	400	400

VARIABLE SPEED DRIVE	
Manufacturer: DREHMO	1
Manufacturer: AUMA	2

ELECTRIC POWER CONTROL	
Frequency converter	FU

ELECTRIC SIGNAL CONTROL	
Automation (please specify details)	A

SPECIAL DESIGN (PLEASE SPECIFY DETAILS)	
	So

**For More Information**

To learn more about Honeywell's  
Advanced Gas Solutions, visit  
[www.honeywellprocess.com](http://www.honeywellprocess.com) or contact  
your Honeywell account manager

**GERMANY****Honeywell Process Solutions**

Honeywell Gas Technologies GmbH  
Osterholzstrasse 45  
34123 Kassel, Deutschland  
Tel: +49 (0)561 5007-0  
Fax: +49 (0)561 5007-107

HON 530-E-WG.00  
2017-01  
© 2017 Honeywell International Inc.

**Honeywell**