

Leakage-Gas Flow Monitoring Device HON 917



PRODUCT INFORMATION

**Serving the Gas Industry
Worldwide**

Honeywell

Leakage-Gas Flow Monitoring Device HON 917

Application, properties, technical specifications

Applications

- The HON 917 is designed for use with Safety Relief Valves and is installed on the outlet of the relief valve to provide an indication of the relief valve status (Open/Closed).
- Designed to meet the requirements of Type-B-SRV according to DIN 33821
 - Simplifies response monitoring of a type-B SRV
 - Simplifies set-point adjustments of a type-B SRV
- Suitable for use with natural gas and all non-aggressive gases, other gases may also be considered on application.

Characteristics

- Easy operation
- Integral overpressure protection
- Replaces a vent gas meter

Specifications	
Device design	With integral overpressure protection (IS)
Max. admissible pressure PS	100 bar
Max. operating pressure p _{max}	100 bar with screwed connections according to DIN EN ISO 8334-1 (formerly DIN 2353) (5 bar with threaded connections with conical external threads R1 according to DIN EN 10226 -1 or ISO 7-1)
Valve seat diameter	28 mm
Response point	$Q_n \leq 100$ l/h (air) or 125 l/h (n. gas)
Fitting position	Vertical (as illustrated)
Temperature range	-20 to +60 °C
Materials	Valve body: Aluminium wrought alloys Internal parts: Plastics/oxide ceramics/Al wrought alloys Indicator: Plastics/oxide ceramics Sealing ring: NBR
CE - sign acc. to PED	
Explosion protection	All mechanical components of this device are without potential ignition sources and/or hot faces. They are not subject to ATEX 95 (94/9/EC). All electronic accessories used at the device, meet ATEX requirements.

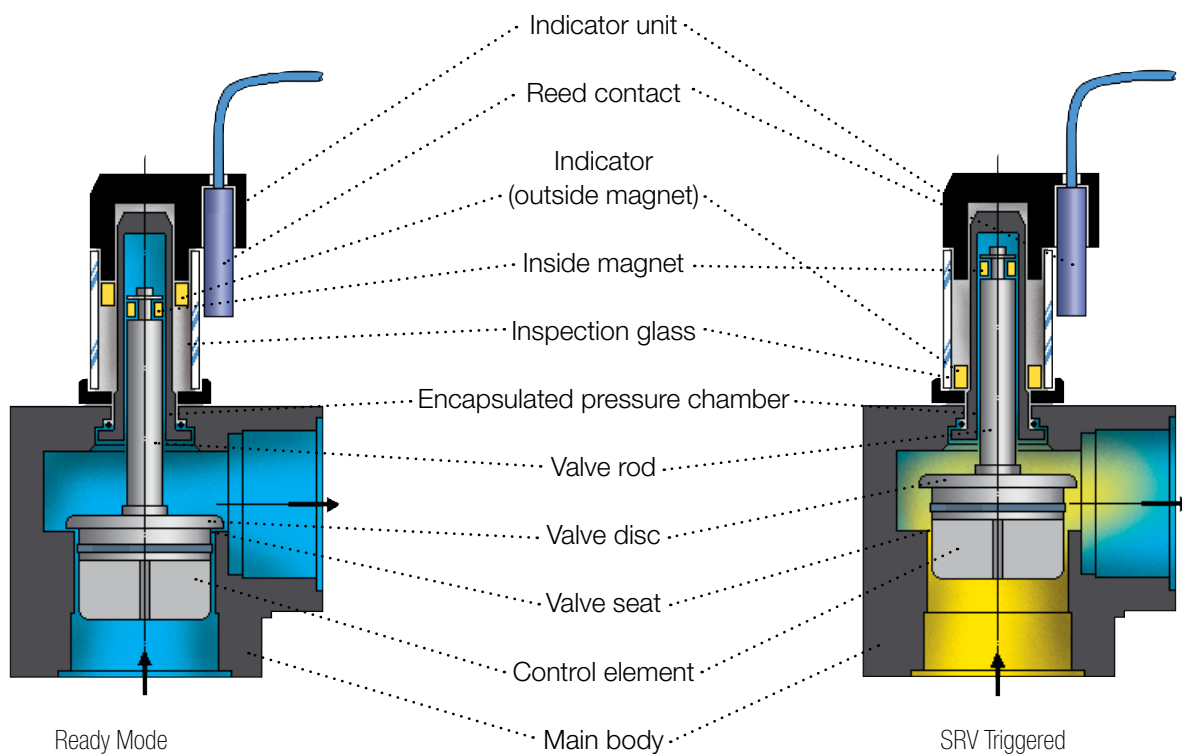

Operation:

The HON 917 is designed to provide a simplified means of monitoring a Safety Relief Valve (SRV) status. It is installed on the outlet of the relief valve, such that in the event of a pressure condition that forces the relief valve to open, this would automatically be sensed by the HON 917 flow monitoring device and provide an indication of relief valve operation.

The device consists of a control element and indicator unit, transmission of signals from the encapsulated pressure chamber to the visual indicator is by means of a magnetic system.

Under normal operating conditions (relief valve closed) the magnetic forces and dead weight of the movable internal parts generate closing forces that maintain the control element in the closed position, 'Ready Mode'.

In the event the upstream SRV is triggered, the closing forces are overcome which forces the control element to open and move up, this in turn moves the inside magnet upwards and allows the outside magnet (indicator) to move downwards - thus indicating that the SRV has been triggered.

For remote indication, the unit can be supplied fitted with a reed contact on the indicator unit, this incorporates a separate switch amplifier with an intrinsically safe circuit (Ex i) for hazardous zones.

Since the "standard electrical equipment" would comprise, passive components e.g. switches according to DIN EN 60079-11 (VDE 0170-7): 2007-08, the reed contact (switch) used for remote indication is therefore exempt from the ATEX directive 94/9/EC and excludes labelling requirements of DIN EN 60079-11: 2007, section 12, though it must fulfil any requirements of that standard that affect its inherent safety (Ex i).

There is an option to employ intrinsically safe circuits (Ex i) for hazardous zones. In that case, all local requirements concerning explosion protection apply to such intrinsically safe circuits (e.g. EX zone).

Leakage-Gas Flow Monitoring Device HON 917

Design and operation

4

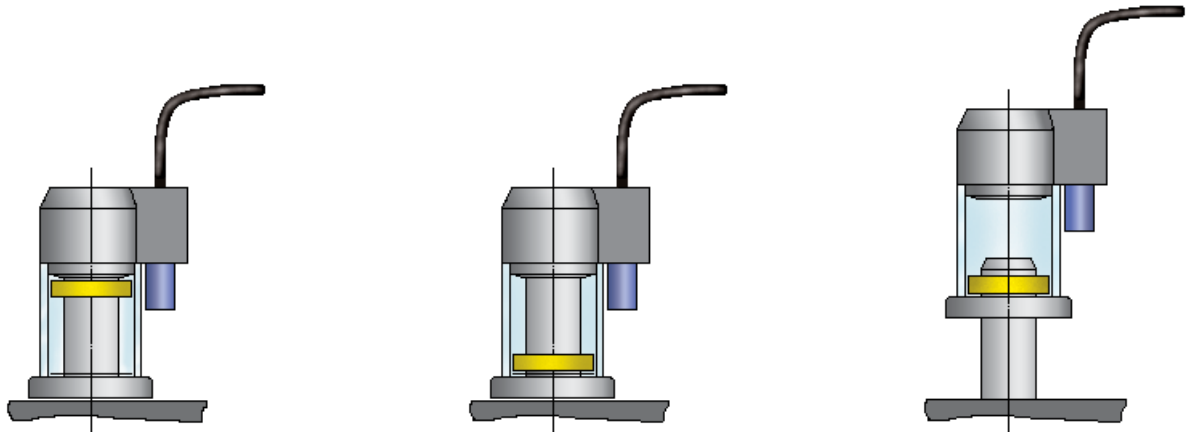

Indicator unit: "Ready"

Indicator unit:
"SRV was triggered"

Indicator unit: Resetting to
"Ready" mode – indicator is
lifted and pushed back until
it sits tight.

Example installation:

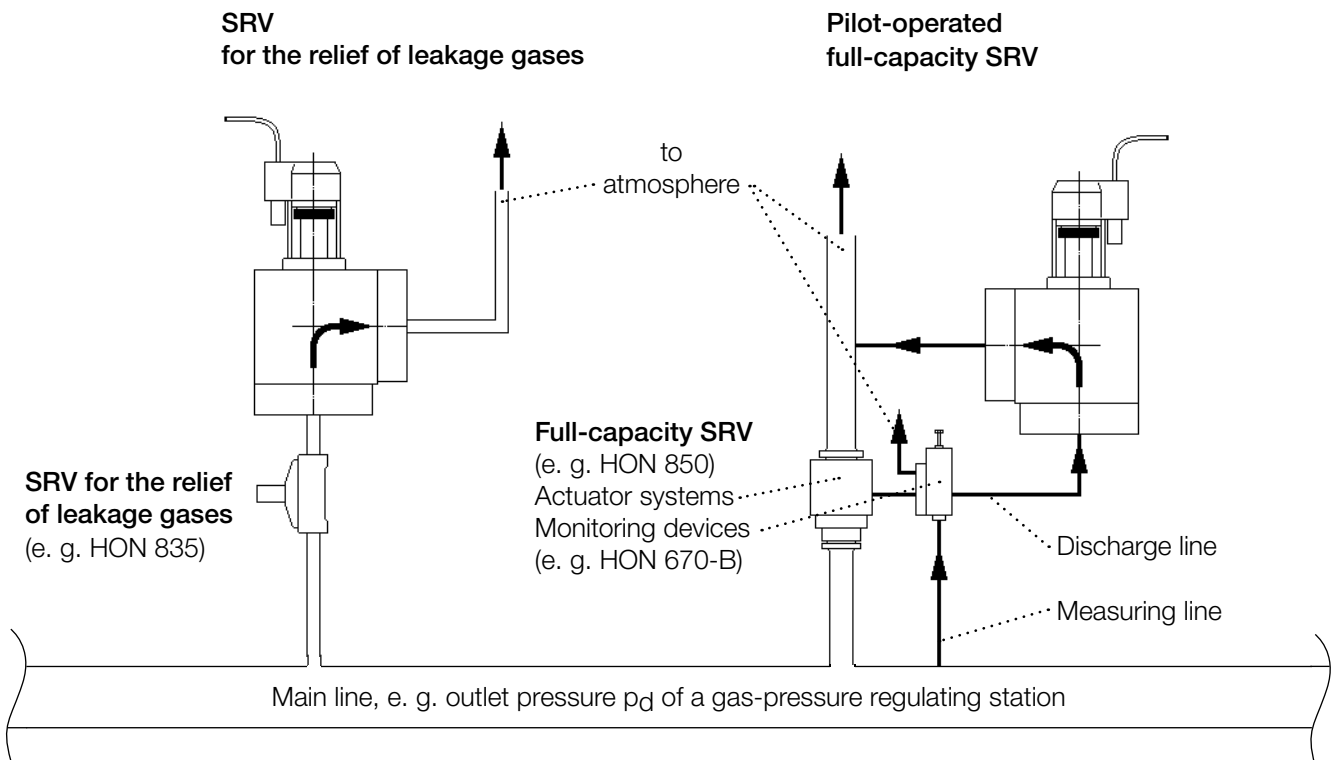

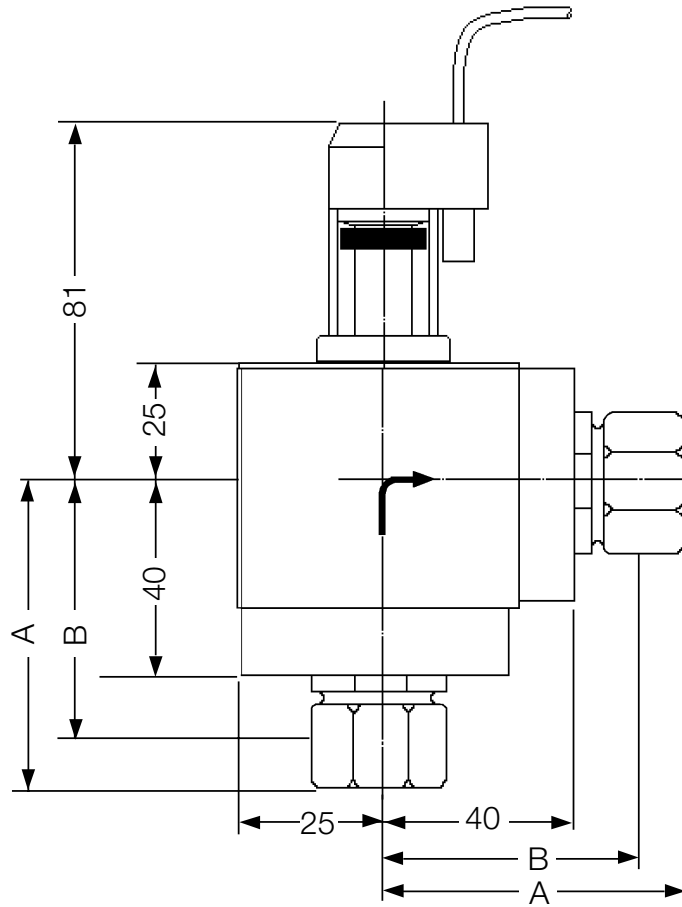

Connections				
SRV	Pipe connection for Monitoring devices	Screwed pipe connection without brazing according to DIN EN ISO 8334-1 (formerly DIN 2353): Outer pipe diameter in mm or internal thread according to DIN EN ISO 228-1 – optionally for inlet or outlet	Width across corners A (mm) from centre body to screw connection	Width across corners B (mm) from centre body to pipe stop
	HON 670-B	10	84	68
	HON 835 Measuring unit 0	12	86	70
	HON 835 Measuring units 1 + 2	22	74	58
		25	87	63
		28	74	58
	HON 832 HON 873	20	117	95
	General	Internal thread G1	38	

Leakage-Gas Flow Monitoring Device HON 917

Device description

Example:

HON 917 - 28 / 28 - F / T

Device number	
Connection, inlet	
Internal thread G1	G1
External pipe Ø 10 mm	10
External pipe Ø 12 mm	12
External pipe Ø 16 mm	16
External pipe Ø 20 mm	20
External pipe Ø 22 mm	22
External pipe Ø 25 mm	25
External pipe Ø 28 mm	28
Connection, outlet	
Internal thread G1	G1
External pipe Ø 10 mm	10
External pipe Ø 12 mm	12
External pipe Ø 16 mm	16
External pipe Ø 20 mm	20
External pipe Ø 22 mm	22
External pipe Ø 25 mm	25
External pipe Ø 28 mm	28
Remote indication	
With remote indication	F
Without remote indication	0
2-channel separating switch amplifier / 20 ... 250 V AC / 20 ... 125 V DC	
With separating switch amplifier	T
Without separating switch amplifier	0

For More Information

To learn more about Honeywell's
Advanced Gas Solutions, visit
www.honeywellprocess.com or contact
your Honeywell account manager

GERMANY**Honeywell Process Solutions**

Honeywell Gas Technologies GmbH
Osterholzstrasse 45
34123 Kassel, Deutschland
Tel: +49 (0)561 5007-0
Fax: +49 (0)561 5007-107

HON 917.00
2017-01
© 2017 Honeywell International Inc.

Honeywell