

Honeywell



HON 5020 SAV Gas Pressure Regulator with Safety Shut-Off Valve, Pilot, and Monitoring Device

Maintenance manual and spare parts

Contents

1	General considerations	4
1.1	About this user manual	4
1.2	About the safety notices	6
2	Description	7
2.1	Intended use	7
2.2	Device models	8
2.3	Labels/Markings	9
2.4	Identifying the device	9
2.5	Layout and operation	12
2.6	Technical specifications	18
3	Safety	24
3.1	Basic safety rules	24
3.2	Requirements concerning the workforce, personal protective gear, workplaces	25
4	Basics for installing the device in a pipe	27
4.1	Installation examples	27
4.2	Meter run characteristics	29
4.3	Operating and measuring lines	31
5	Transport and installation	32
5.1	Transporting the gas pressure regulator	32
5.2	Installing the gas pressure regulator	33
5.3	Installing the device connections	35
5.4	Checking the system for leaks	36
6	Adjusting the settings of the device	39
6.1	Adjusting the loading pressure	39
6.2	Adjusting the control stage setpoint	40
6.3	Adjusting the amplifying valve	41
6.4	Setting and commissioning the safety shut-off valve	43
6.4.1	How the integrated safety shut-off valve works	43
6.4.2	Installing the test layout	44
6.4.3	Checking the SSV for tightness	46
6.4.4	Completing the function check	48
6.4.5	Closing SSV flaps manually	48
6.4.6	Opening the valve	49
6.4.7	Faults and anomalies	54
7	Maintenance	56
7.1	Maintenance schedule	56
7.2	Preparing for the maintenance	57
7.3	Starting maintenance	58
7.4	Maintaining the actuator assembly	64
7.4.1	Removing the triggering unit - 1" size	64
7.4.2	Removing the triggering unit - 2", 3", 4" size	66
7.4.3	Removing the triggering unit - 6" size	68
7.4.4	Maintaining the actuator assembly - all sizes	73

7.4.5	Maintaining the triggering unit - 1" size	75
7.4.6	Maintaining the triggering unit - 2", 3", 4" size	79
7.4.7	Maintaining the triggering unit - 6" size	85
7.4.8	Maintaining the HON 910 push-button valve - 6" size	86
7.4.9	Installing the triggering unit - 1" size	88
7.4.10	Installing the triggering unit - 2", 3", 4" size	90
7.4.11	Installing the triggering unit - 6" size	91
7.5	Completing the maintenance	98
8	Storage and disposal	101
8.1	Storing the device	101
8.2	Disassembling the device	101
8.3	Disposing of the device	103
9	Appendix	104
9.1	Additional information regarding spare parts	104
9.2	Spare parts for actuator assembly with triggering unit - 1" size	105
9.3	Spare parts for actuator assembly with triggering unit - 2", 3", 4" size	108
9.4	Spare parts for actuator assembly with triggering unit - 6" size	121
9.5	Spare parts for HON 910 push-button valve for actuator assembly with 6" size	124
9.6	Spare parts for travel indication option	125
9.7	Lubricants	126

1 General considerations

Contents

Topic	Page
About this user manual	4
About the safety notices	6

1.1 About this user manual

Validity and purpose	<p>This user manual applies to HON 5020 SAV gas pressure regulators featuring a safety shut-off valve in combination with a pilot and a monitoring device.</p> <p>At certain points, this user manual refers to detailed descriptions in the component documentation for the pilot and the monitoring device.</p> <p>This user manual provides all individuals with the information required for the safe handling in connection with the following tasks:</p> <ul style="list-style-type: none"> ▪ Transport ▪ Installation ▪ Start-up ▪ Set-up ▪ Maintenance ▪ Decommissioning, disassembly, renewed start-up, storage and disposal
Target group	<p>This user manual is intended for anyone working with the product:</p> <ul style="list-style-type: none"> ▪ Transportation personnel ▪ Installation personnel ▪ Set-up and operating personnel ▪ Maintenance and service personnel
Illustration	<p>Honeywell offers products with identical functions in a number of different sizes. For this reason, we are unable to guarantee that illustrations in this user manual coincide with the dimensions of your product. In these cases, the illustrations should be viewed as a concept sketch.</p>
 Safety	<p>Failing to observe the information provided in this document may lead to injuries, including death and material damages.</p> <p>To ensure the safety, any persons handling the product must have read and understood the following parts of this document before they start with any work involving it:</p> <ul style="list-style-type: none"> ▪ the chapter entitled Safety ▪ the chapters that describe the work to be done
Copyright notice	<p>Unless explicitly permitted, the disclosure as well as duplication of this document, the exploitation and communication of its contents are prohibited. Any breach or infringement will result in liability for damages. All rights reserved in the event of patent, utility model or registered design registration.</p>

Copyright

© Copyright 2020 by
Honeywell Process Solutions
Honeywell Gas Technologies GmbH
Osterholzstraße 45
34123 Kassel
GERMANY

Tel: +49 561 5007-0
Phone number for service: +49 561 5007-180
Fax: +49 561 5007-107
Fax number for service: +49 561 5007-108
E-mail: gas-ks@honeywell.com
Website:
www.honeywellprocess.com
www.hongastec.de
Printed in Germany

Details about the manufacturer's liability

The manufacturer is not liable for damages and malfunctions arising from non-observance of this user manual and the other applicable documents.

Constructive changes

The written approval from Honeywell Gas Technologies GmbH, Kassel, is required for any modifications and additions to the product. Any violation will void the legal liability for consequences arising thereof.

1.2 About the safety notices





Meaning

The information contained in the safety notices is intended to prevent personal injury. Safety notices contain the following information:

- Nature and source of the danger
- Possible consequences associated with the non-observance of the notice
- Procedures for the prevention of personal injury

Types of safety notices

This document contains the following types of safety notices:

Type of safety notice	Description	Sign
Basic safety notices	Superordinate safety notices not relating to a specific task: <ul style="list-style-type: none"> ▪ They contain a summarized description of hazards, risks and safety procedures associated with the handling of the device. ▪ Their purpose is to inform and educate the user about an existing danger and about practicing behavioral safety. ▪ They are suitable as safety instruction for all employees handling the device. 	Recognizable by the heading of the chapter
Instruction-related safety notices	Safety notices containing specific instructions relating to the entire manual or a group of manuals	  
Step-related safety notices	Safety notices containing specific instructions relating only to the step	DANGER WARNING CAUTION
Additional safety notice	Instruction to observe certain safety notices with reference to a location in the document where safety notices containing specific information about dangers, risks and specific instructions for safety procedures can be found	

Danger levels

The safety notices containing specific instructions are identified with a signal word. The signal word represents a certain danger level:

Danger level	If you fail to follow the instruction, then ...	And the consequence is ...
DANGER	an accident will happen	serious bodily injury or death.
WARNING	an accident may happen	possible serious bodily injury or death.
CAUTION	an accident may or will happen.	minor or moderate bodily injury.

Warnings about material damages

Warnings about possible material damages are identified with the word **Attention** in this document.

2 Description

Contents

Topic	Page
Intended use	7
Device models	8
Labels/Markings	9
Identifying the device	9
Layout and operation	12
Technical specifications	18

2.1 Intended use

Intended use

The HON 5020 with SAV actuator assembly must be used and operated exclusively with a compatible pilot and a compatible monitoring device made by Honeywell. It is intended to be used, in combination with an appropriate pilot and an appropriate monitoring device, as a gas pressure regulator with a safety-shut off function in a regulating line.

Depending on the pilot model used in combination with the actuator assembly, the latter can be used to maintain the outlet pressure of a gas constant within the regulating line, regardless of the influence of disturbance variables such as pressure changes and/or discharge changes.

Depending on the monitoring device's design, the integrated SAV can be actuated if there is excessive pressure or insufficient pressure.

As a gas pressure regulator, it can also be used at transfer stations used in gas transportation networks, as well as in power plants and industrial facilities. The HON 5020 -with-SAV actuator assembly unit can be used with natural gas or dry, non-aggressive industrial gases.

Note: The utilization limits of the device with regard to the medium, operating pressure and operating temperature can be gathered from the type plate attached on the device or the technical specifications.

The use under different operating conditions must be coordinated in consultation with the manufacturer.

Limitations of use

Please observe the following limitations of use:

- Do not use the device for any media other than those mentioned in the intended use or those discussed with and approved by the manufacturer.
- Do not use the device in any installation position other than the one documented in this user manual.
- Do not use the device against the direction of flow specified on the device and in the user manual.
- When replacing defective parts, only use original spare parts or manufacturer-approved standard parts.
- Do not attempt to modify or remodel the device on your own.

2.2 Device models

Gas pressure regulator versions

Gas pressure regulators consisting of an HON 5020 actuator assembly combined with an integrated SAV, pilot, and monitoring device are available in a number of versions.

HON 5020 actuator assembly models

The following table shows which models are available:

Nominal diameters of 1" (DN 25); 2" (DN 50); 3" (DN 80); 4" (DN 100), and 6" (DN 150) with					
Flange facing as defined by standard	Pressure rating	Maximum operating pressure		Flange facing	Thread type
		[bar]	[psi]		
ASME B16.5	Class 150	20	290	Raised face	IMPERIAL*; METRIC
	Class 300	51	740		
	Class 600	102	1479		
DIN EN 1092-1	PN 16	16	232	B flange	METRIC
	PN 25	25	363		
	PN 40	40	580		

* For the IMPERIAL version, the pilots HON640A, S60, as well as the controllers HON670 and HON672 are also available in IMPERIAL. The screw connection and piping are also executed accordingly in IMPERIAL (Swagelok, stainless steel).

Versions and designs in this user manual

The *technical specifications*, the *Maintenance* section, and the spare parts lists and spare parts drawings in the *appendix* describe all the actuator assembly and integrated SAV models available. Special-purpose versions are identified with "SO" in the inspection certificate, which is included with the gas pressure regulator.

The *technical specifications*, the *Maintenance* section, and the spare parts lists and spare parts drawings in the *appendix* for the pilot and the monitoring device can be found in the *component documentation* for the corresponding device.

The remaining sections in this user manual mostly use the version with the HON 630 pilot and the HON 670 / 671 monitoring device as a reference. However, other versions and models will be covered specifically as well when there are important differences that need to be pointed out.

For information regarding the installed pilot or monitoring device version and model, please refer to the *component documentation* for the corresponding device.

If you have trouble understanding the information in this documentation, contact the manufacturer without fail before starting any work on the device.

2.3 Labels/Markings

Illegible labels



Illegible information on the device poses a risk of injury due to resulting erroneous operation, use, or installation.

Labels, as well as inscriptions and stamping on the device, can eventually become soiled or otherwise unrecognizable to such an extent that users will not be warned effectively of hazards and may be unable to follow required operating instructions. This will pose a risk of injury.

⇒ Make sure to always keep all relevant labels in good condition so that they will be easily legible.

⇒ Immediately replace damaged and missing labels.

Labels on the HON 5020 actuator assembly

The following labels/markings can be found on the actuator assembly's casing:

Figure	No.	Meaning
	1	Nameplate
	2	Body part number
	3	<ul style="list-style-type: none"> ▪ Batch number ▪ Foundry code
	4	CE PIN (only if the unit has been granted a CE type approval)
	5	Body nominal size
	6	Arrow indicating the direction of flow

Nameplate

For a detailed list of the information on the nameplate and what it means:

Identifying the device (see page 9)

Labels on connection lines

Small labels must be used to color-code and explicitly name the actuator assembly's connection lines based on what the lines are intended for and their minimum nominal size.

2.4 Identifying the device

Identifying the gas pressure regulator

Make sure you have the right manual for your gas pressure regulator.

Use the nameplates to identify the gas pressure regulator.

Verifying the technical specifications

Make sure that the conditions on site match the information on the type plate and the technical specifications.

Technical specifications (see page 18)

Locating the type plate of the actuator assembly

The type plate of the actuator assembly can be found here:

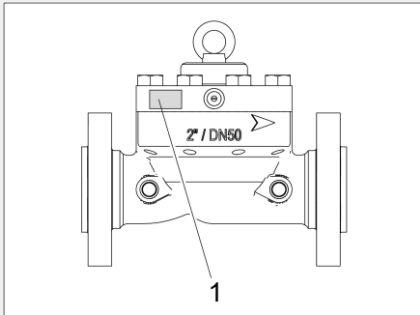
Figure	No.	Meaning
	1	Front of the actuator assembly

Interpreting the type plate of the actuator assembly

The details on the type plate have the following meaning:

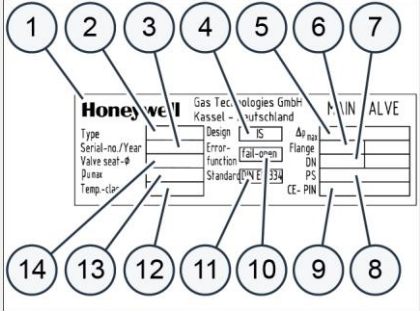
Figure	No.	Meaning
	1	Manufacturer
	2	Model name
	3	Serial number of the device/ Manufacturing date (year)
	4	Device version (IS = version with integral overpressure protection)
	5	Maximum allowable pressure differential
	6	Flange type
	7	Nominal size
	8	Maximum allowable pressure
	9	CE marking
	10	Failure function (fail-open)
	11	Standard (EN 334)
	12	Temperature class
	13	Maximum allowable inlet pressure
	14	Valve seat diameter

Locating the type plate of the pilot

The type plate of the pilot can be found here:

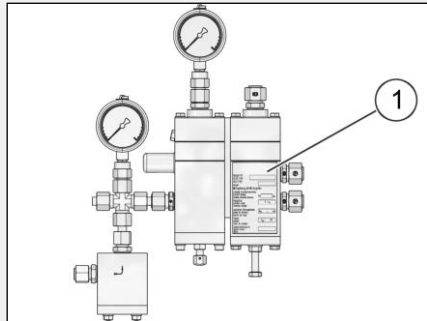
Figure	No.	Description
	1	Front of control stage

Interpreting the type plate of the pilot

The details on the type plate have the following meaning:

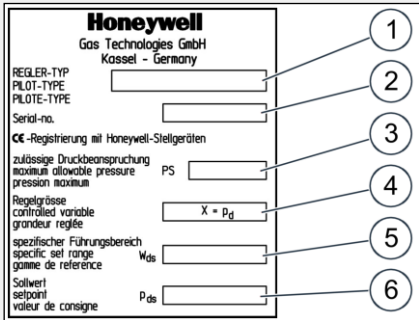
Figure	No.	Meaning
	1	Name of the device
	2	Serial number
	3	Maximum allowable pressure
	4	Controlled variable
	5	Specific set range
	6	Setpoint

Locating the monitoring device's type plates

The monitoring device type plate locations are as follows:

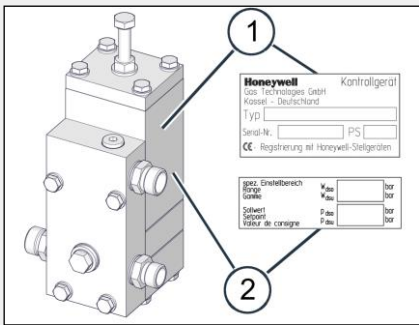
Figure	No.	Description
	1	Type plate on the side of the monitoring device
	2	Additional type plate on the side of the monitoring device

Interpreting the type plate on the monitoring device

The details on the type plate have the following meaning:

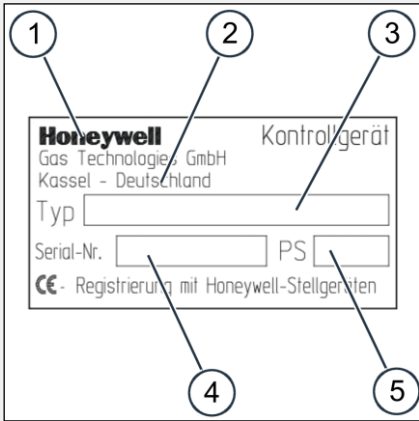
Figure	No.	Description
	1	Manufacturer ID
	2	Manufacturer's address
	3	Type designation
	4	Serial number
	5	PS = Maximum allowable pressure

Interpreting the additional type plate on the monitoring device

The details on the additional type plate mean the following:

Figure	No.	Description
	1	Specific adjustment range [bar] W_{dso} = Excess pressure
	2	Specific adjustment range [bar] W_{dso} = Insufficient pressure
	3	Setpoint to be set [bar] p_{dso} = Upper response pressure value
	4	Setpoint to be set [bar]; see configuration p_{dsu} = Lower response pressure value

2.5 Layout and operation

Figure

The figure below shows a version of the HON-5020-with-SAV actuator assembly in combination with a pilot and a monitoring device.

The gas pressure regulator is made up of the following assemblies:

Figure	No.	Description
	1	HON 630 pilot (example)
	2	HON 5020 actuator assembly with SAV
	3	HON 670 / 671 monitoring device (example)

How the actuator assembly works

In combination with an appropriate Honeywell pilot and Honeywell monitoring device, the HON 5020 -with-SAV actuator assembly can be used as a gas pressure regulator with a safety shut-off function in order to maintain the outlet pressure of a gas constant within the regulating line regardless of the influence of disturbance variables such as pressure changes and/or discharge changes.

The pressure that needs to be regulated is fed to the pilot via the sensing line. The diaphragm system in the pilot determines the pressure actual value as a force on the measuring diaphragm and compares it with the force of the pilot spring, which is used as reference variable. If control deviations are detected based on the results from this comparison, the opening position of the actuator assembly's regulating diaphragm will be changed by adjusting the motorization pressure so that the pressure being regulated (actual value) will change to match the setpoint. When there is zero pressure flow, the device seals tightly.

How the integrated safety shut-off valve works

While the pilot is performing its regulating function, the gas pressure being monitored will be present at the monitoring device. This monitoring device will compare the current gas pressure with the preset response pressure. Depending on the specific monitoring device being used, the monitoring device will trigger the switching device if the current pressure exceeds and/or falls below the set response pressure. This, in turn, will cause the safety shut-off valve to be closed. The specific closing mechanisms will vary depending on the size of the assembly. The valve plate will seal off the inlet pressure area in the actuator assembly and stop the flow of gas.

It will not be possible to reopen the safety shut-off valve until the gas pressure in the downstream system decreases by the re-engage differential in the direction of the setpoint range. The safety shut-off valve needs to be opened manually.

Re-engage differential

The term “re-engage differential” (Δp_o and Δp_u) refers to the minimum pressure differential between the upper response value (p_{so}) and the lower response value (p_{su}). This re-engage differential specifies the minimum value by which the pressure needs to decrease towards the setpoint (after the safety shut-off valve has closed) so that it will be possible to reopen the safety shut-off valve manually.

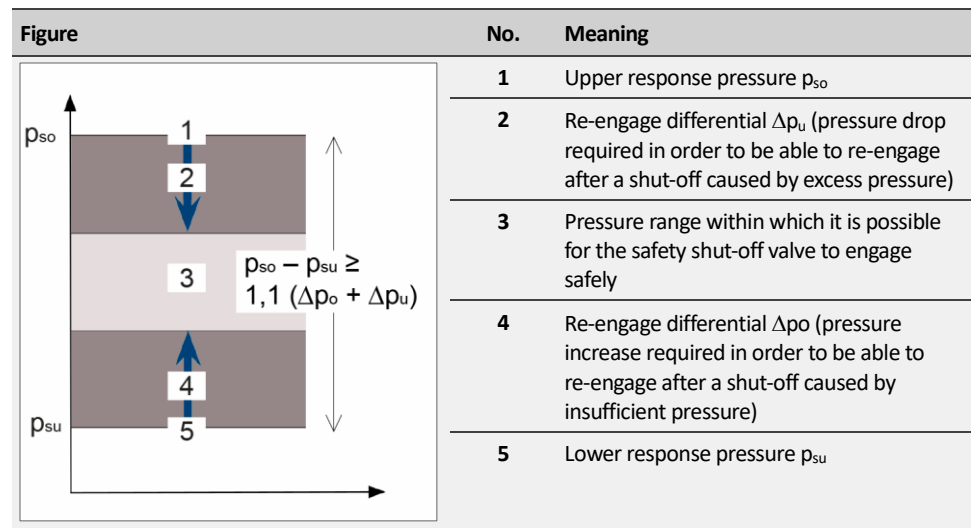

Configuration of an actuator assembly with a size of 1"

Assembly components:

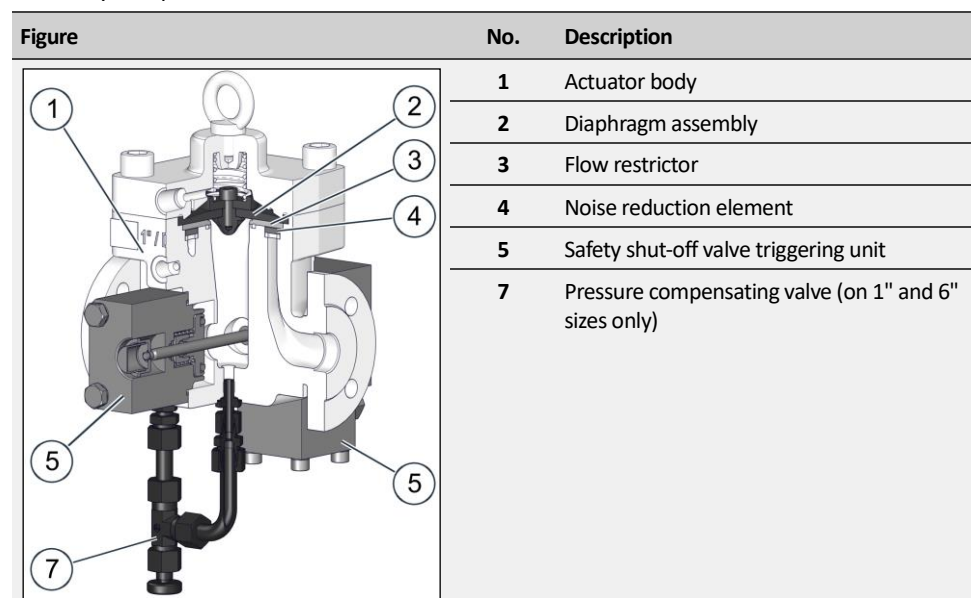

Configuration of an actuator assembly with a size of 2", 3", or 4"

Assembly components:

Figure	No.	Description
	1	Actuator body
	2	Diaphragm assembly
	3	Flow restrictor
	4	Noise reduction element
	5	Safety shut-off valve triggering unit

Configuration of an actuator assembly with a size of 6"

Assembly components:

Figure	No.	Description
	1	Actuator body
	2	Diaphragm assembly
	3	Flow restrictor
	4	Noise reduction element
	5	Safety shut-off valve triggering unit
	7	Pressure compensating valve (on 1" and 6" sizes only)

Pressure sections of an actuator assembly with a size of 1"

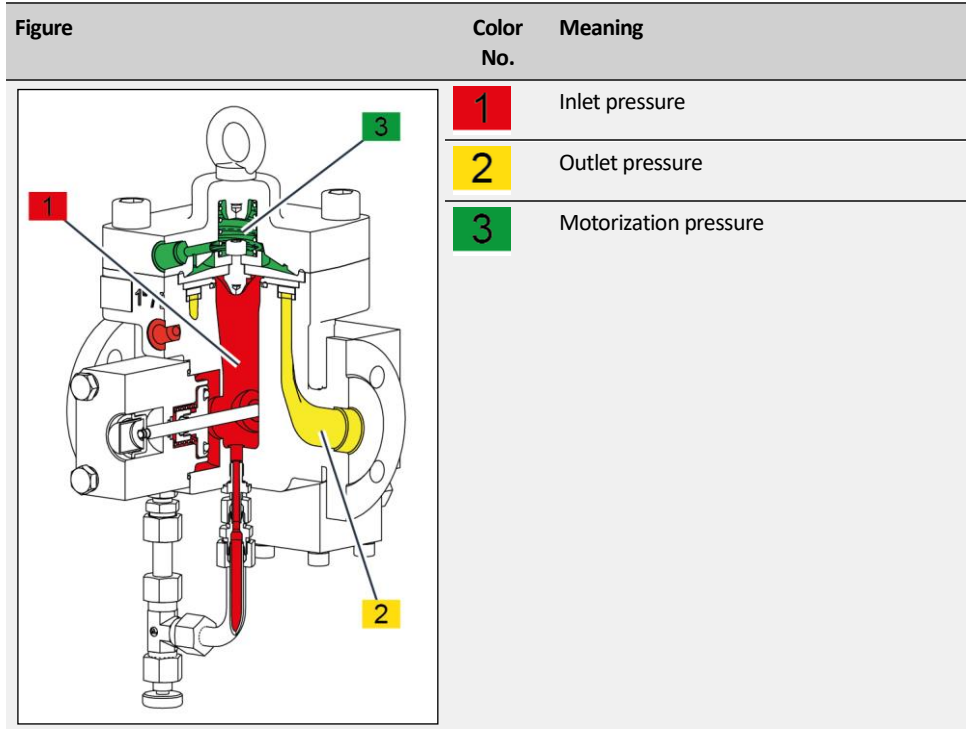

Pressure sections of an actuator assembly with a size of 2", 3", 4"

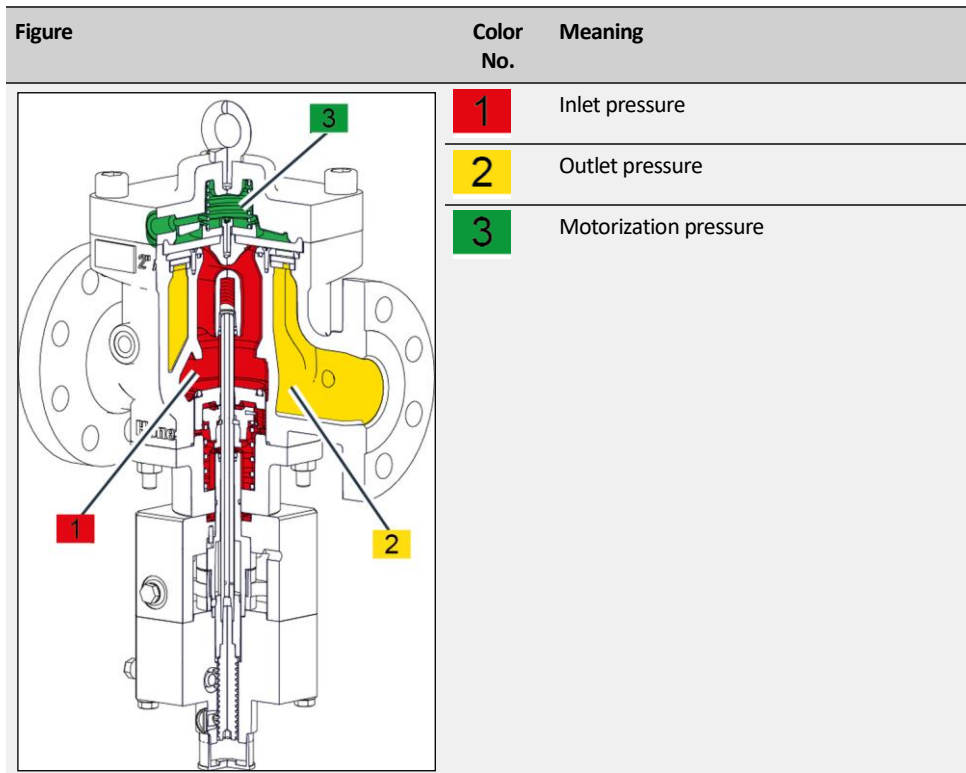

Pressure sections of an actuator assembly with a size of 6"

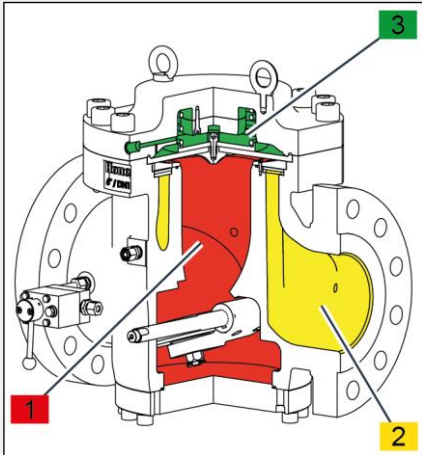
Figure	Color No.	Meaning
	1	Inlet pressure
	2	Outlet pressure
	3	Motorization pressure

Actuator assembly connection lines

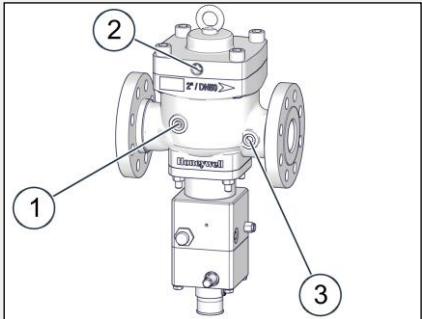
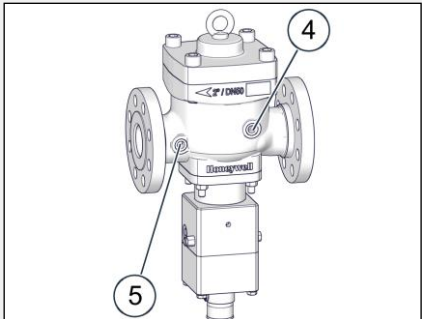
Figure (similar for all sizes)	No.	Connection	Pipe connection thread type	
			Metric	Imperial
Front:				
	1	Inlet pressure	E10L	3/8"
	2	Motorization pressure	E10L	3/8"
	3	Outlet pressure / discharging	E12L	1/2"
Back:				
	4	Inlet pressure	E10L	3/8"
	5	Outlet pressure / discharging	E12L	1/2"

The actuator assembly's connections have the following dimensions:

- **M 14 x 1.5** if the pilot being connected uses the metric system
- **3/8" NPT** if the pilot being connected uses the imperial system

Travel indication option

The numbers have the following meaning:

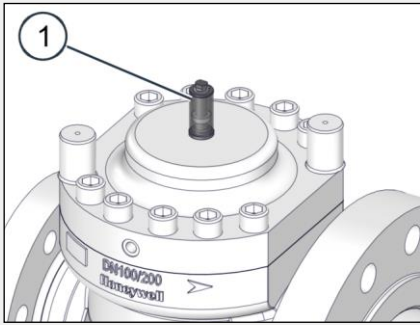
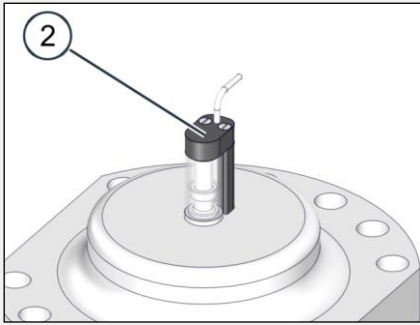
Figure	No.	Description
	1	Optical travel indicator
	2	Optical travel indicator with remote control

How the travel indication option works

Optical travel indicator

- The regulator is in the closed position when the magnet is located completely behind the diffuse surface.
- When the travel position is in the open position, this is not a position indicator, but only shows that the regulator is in operation.

Optical travel indicator with remote control

- The optical travel indication can also be equipped with a remote indication.
- The positions open and closed are switched by means of a reed contact.
- The remote indication is also not a position indicator, but only shows whether or not the regulator is in operation.

2.6 Technical specifications

Materials

Criterion	Value
Actuator assembly materials	Case: Steel Internal parts: Steel Diaphragm: Elastomer Gaskets: Elastomer
Pilot materials	Case: Aluminum alloy Internal parts: Aluminum alloy/steel Diaphragms: NBR Gaskets: NBR
Monitoring device materials	Case: Aluminum alloy Internal parts: Aluminum alloy/steel Diaphragms: NBR Gaskets: NBR

Environmental conditions

Criterion	Value
Maximum temperature range	-40 °F – +175 °F (-40 °C – +79 °C)

Pressure rating and flange facing standards

There are various flange facings for the nominal diameters of 1" (DN 25); 2" (DN 50); 3" (DN 80); 4" (DN 100), and 6" (DN 150), as specified in the following standards:

- **ASME B16.5**
Pressure rating as per Class 150; 300; 600 / Class 150 = 20 bar (290 psi);
Class 300 = 51 bar (740 psi); Class 600 = 102 bar (1479 psi)
Flange facing: Raised face
- **DIN EN 1092-1**
Pressure rating as per PN 16; 25; 40 / PN 16 = 16 bar (232 psi); PN 25 = 25 bar (363 psi); PN 40 = 40 bar (580 psi)
Flange facing: B flange

Dimensions and weights
for a HON 5020 SAV with
a size of 1"

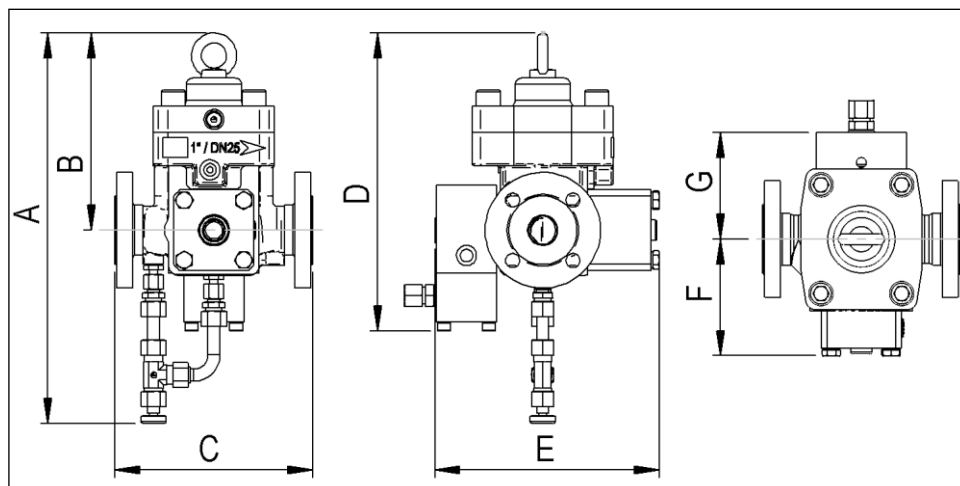

Size	PN	Class	A inches (mm)	B inches (mm)	C inches (mm)	D inches (mm)	E inches (mm)	F inches (mm)	G inches (mm)	Weight lbs (kg)
1" (DN 25)	16	150	15.28 (388)	7.56 (192)	7.24 (184)	11.61 (295)	8.74 (222)	4.92 (125)	3.6 (91.5)	37.5 (17)
1" (DN 25)	25 / 40	300	15.28 (388)	7.56 (192)	7.76 (197)	11.61 (295)	8.74 (222)	4.92 (125)	3.6 (91.5)	37.5 (17)
1" (DN 25)		600	15.28 (388)	7.56 (192)	8.27 (210)	11.61 (295)	8.74 (222)	4.92 (125)	3.6 (91.5)	39.7 (18)

Dimensions and weights
for a HON 5020 SAV with
a size of 1"-2" Body with
expander as example

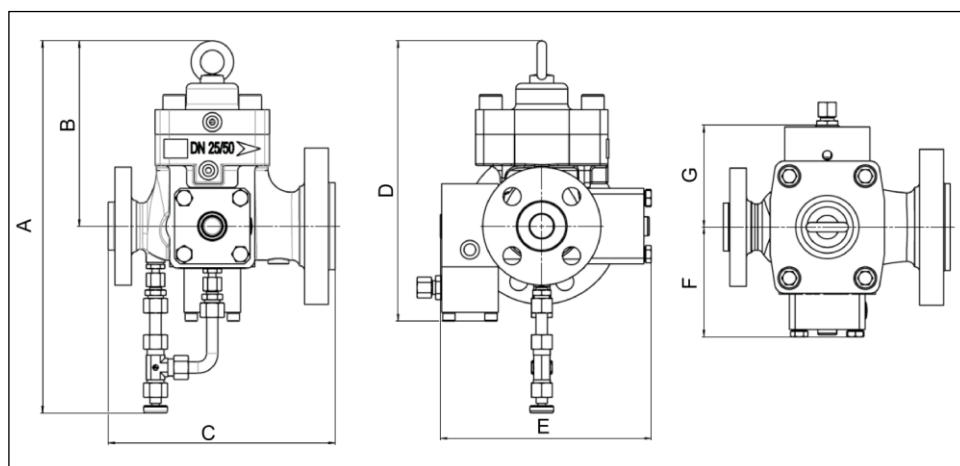

Size	PN	Class	A inches (mm)	B inches (mm)	C inches (mm)	D inches (mm)	E inches (mm)	F inches (mm)	G inches (mm)	Weight lbs (kg)
1"-2" (DN 25-50)	16 / 25 / 40									35.9 (16.3)
1"-2" (DN 25-50)		150	15.59 (396)	7.72 (196)	9.45 (240)	11.65 (296)	8.74 (222)	4.57 (116)	4.17 (106)	35.7 (16.2)
1"-2" (DN 25-50)		300								36.2 (16.4)
1"-2" (DN 25-50)		600								39.9 (18.1)

Dimensions and weights
for a HON 5020 SAV with
a size of 2", 3", or 4"

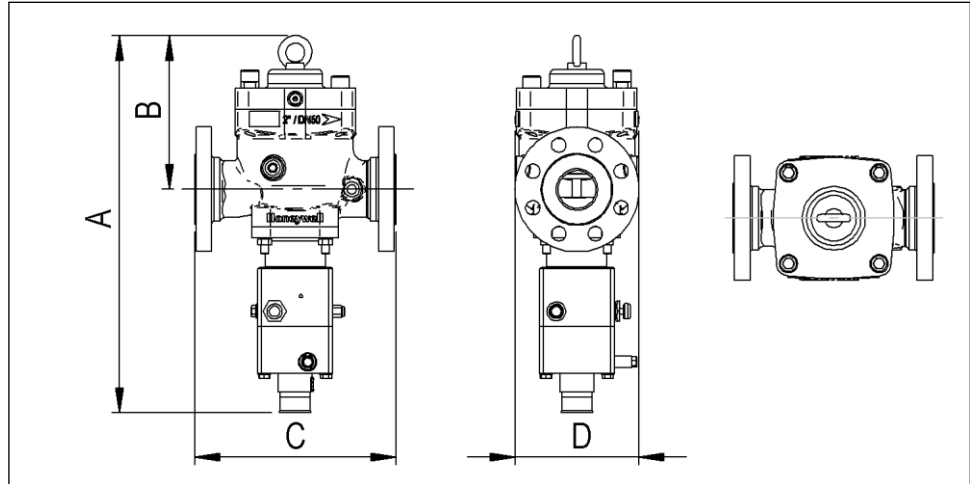

Size	PN	Class	A inches (mm)	B inches (mm)	C inches (mm)	D inches (mm)	Weight lbs (kg)
2" (DN 50)	16	150	19.69 (500)	7.87 (200)	10 (254)	6.46 (164)	68.3 (31)
2" (DN 50)	25 / 40	300	19.69 (500)	7.87 (200)	10.51 (267)	6.46 (164)	70.5 (32)
2" (DN 50)		600	19.69 (500)	7.87 (200)	11.26 (286)	7.87 (200)	82.9 (37.6)
3" (DN 80)	16	150	21.42 (544)	9.06 (230)	11.73 (298)	9.53 (242)	98.5 (44.7)
3" (DN 80)	25 / 40	300	21.42 (544)	9.06 (230)	12.45 (317)	9.53 (242)	109.1 (49.5)
3" (DN 80)		600	21.42 (544)	9.06 (230)	13.27 (337)	9.84 (250)	120.2 (54.5)
4" (DN 100)	16	150	22.76 (578)	10.47 (266)	13.86 (352)	11.26 (286)	166.2 (75.4)
4" (DN 100)	25 / 40	300	22.76 (578)	10.47 (266)	14.49 (368)	11.42 (290)	191.8 (87)
4" (DN 100)		600	22.76 (578)	10.47 (266)	15.51 (394)	11.42 (290)	220.5 (100)

Dimensions and weights for a HON 5020 SAV with a size of 2"-4", 3"-6", or 4"-8" Body with expander as example

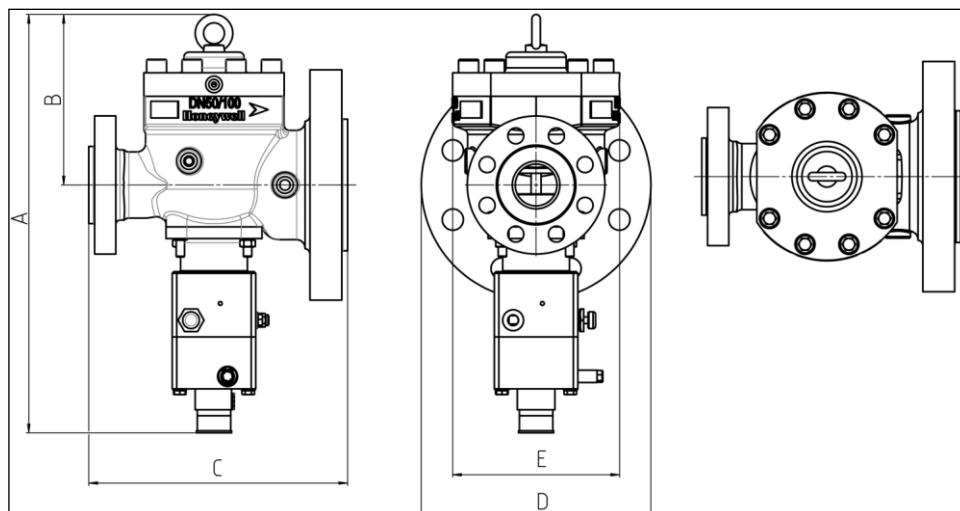

Size	PN	Class	A inches (mm)	B inches (mm)	C inches (mm)	D inches (mm)	Weight lbs (kg)
2"-4" (DN 50-100)	16					8.66 (220)	78.5 (35.6)
2"-4" (DN 50-100)	25 / 40					9.25 (235)	82.7 (37.5)
2"-4" (DN 50-100)		150	19.69 (500)	8.07 (205)	12.20 (310)	9.06 (230)	82.9 (37.6)
2"-4" (DN 50-100)		300				10.04 (255)	90.0 (40.8)
2"-4" (DN 50-100)		600				10.83 (275)	112.2 (50.9)
3"-6" (DN 80-150)	16					11.22 (285)	118.8 (53.9)
3"-6" (DN 80-150)	25 / 40					11.81 (300)	132.3 (60.0)
3"-6" (DN 80-150)		150	21.65 (550)	9.06 (230)	15.75 (400)	11.02 (280)	120.4 (54.6)
3"-6" (DN 80-150)		300				9.06 (230)	141.8 (64.3)
3"-6" (DN 80-150)		600				13.98 (355)	169.1 (76.7)
4"-8" (DN 100-200)	16					18.11 (460)	205.7 (93.3)
4"-8" (DN 100-200)	25					19.09 (485)	234.6 (106.4)
4"-8" (DN 100-200)	40					20.28 (515)	241.7 (109.6)
4"-8" (DN 100-200)		150	22.83 (580)	10.63 (270)	16.93 (430)	19.09 (485)	207.9 (94.3)
4"-8" (DN 100-200)		300				20.47 (520)	244.5 (110.9)
4"-8" (DN 100-200)		600				22.05 (560)	298.8 (135.5)

Dimensions and weights for a HON 5020 SAV with a size of 6"

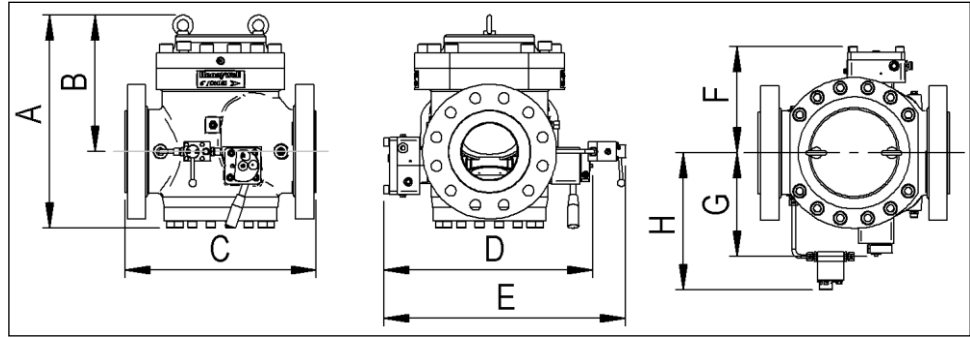

Size	PN	Class	A inches (mm)	B inches (mm)	C inches (mm)	D inches (mm)	E inches (mm)	F inches (mm)	G inches (mm)	H inches (mm)	Weight lbs (kg)
6" (DN 150)	16	150	21.93 (557)	13.43 (341)	17.76 (451)	21.5 (546)	25.28 (642)	10.83 (275)	10.83 (275)	14.25 (362)	460.8 (209)
6" (DN 150)	25 / 40	300	21.93 (557)	13.43 (341)	18.62 (473)	21.5 (546)	25.28 (642)	10.83 (275)	10.83 (275)	14.25 (362)	500.4 (227)
6" (DN 150)		600	21.93 (557)	13.43 (341)	20 (508)	21.5 (546)	25.28 (642)	10.83 (275)	10.83 (275)	14.25 (362)	608.5 (276)

Dimensions and weights for a HON 5020 SAV with a size of 6"-12" Body with expander as example

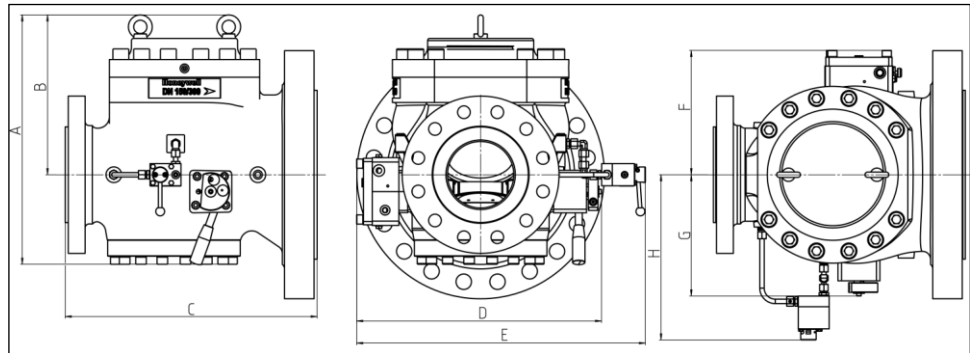

Size	PN	Class	A inches (mm)	B inches (mm)	C inches (mm)	D inches (mm)	E inches (mm)	F inches (mm)	G inches (mm)	H inches (mm)	Weight lbs (kg)
6"-12" (DN 150-300)	16										541.3 (245.5)
6"-12" (DN 150-300)	25										589.4 (267.3)
6"-12" (DN 150-300)	40		22.24 (565)	14.21 (361)	22.44 (570)	21.85 (555)	25.79 (655)	11.06 (281)	10.83 (275)	14.69 (373)	617.4 (280.0)
6"-12" (DN 150-300)		150									562.3 (255.0)
6"-12" (DN 150-300)		300									619.6 (281.0)
6"-12" (DN 150-300)		600									796.0 (361.0)

**Operating pressure,
Class 150**

Criterion	Value
Nominal diameter	1" (DN 25), 2" (DN 50), 3" (DN 80), 4" (DN 100), 6" (DN 150)
Maximum operating pressure	290 psi (20 bar)

**Operating pressure,
Class 300**

Criterion	Value
Nominal diameter	1" (DN 25), 2" (DN 50), 3" (DN 80), 4" (DN 100), 6" (DN 150)
Maximum operating pressure	740 psi (51 bar)

**Operating pressure,
Class 600**

Criterion	Value
Nominal diameter	1" (DN 25), 2" (DN 50), 3" (DN 80), 4" (DN 100), 6" (DN 150)
Maximum operating pressure	1479 psi (102 bar)

**Operating pressure,
PN 16**

Criterion	Value
Nominal diameter	1" (DN 25), 2" (DN 50), 3" (DN 80), 4" (DN 100), 6" (DN 150)
Maximum operating pressure	232 psi (16 bar)

**Operating pressure,
PN 25**

Criterion	Value
Nominal diameter	1" (DN 25), 2" (DN 50), 3" (DN 80), 4" (DN 100), 6" (DN 150)
Maximum operating pressure	363 psi (25 bar)

**Operating pressure,
PN 40**

Criterion	Value
Nominal diameter	1" (DN 25), 2" (DN 50), 3" (DN 80), 4" (DN 100), 6" (DN 150)
Maximum operating pressure	580 psi (40 bar)

ATEX specifications

The mechanical components of the device do not have any potential ignition sources. Consequently, they are not subject to the requirements of the ATEX 95 Equipment Directive (94/9/EU).

3 Safety

Contents

Topic	Page
Basic safety rules	24
Requirements concerning the workforce, personal protective gear, workplaces	25

3.1 Basic safety rules

Target group of these rules	These rules are intended for any individuals handling the device.
Purpose of these rules	These rules are designed to make sure that any individuals handling the device obtain detailed information about the dangers and safety procedures and observe the safety notices contained in the user manual and on the device. If you do not follow these rules, there is a risk of injury including death and material damages.
Handling the user manual	<p>Observe the following rules:</p> <ul style="list-style-type: none"> ▪ Read the chapter entitled Safety and the chapters relating to your responsibilities in their entirety. It is vital that you have understood these contents. ▪ Always keep the user manual close by the device so that you can refer to it again. ▪ Include the user manual if you are giving the device away.
Handling the device	<p>Observe the following rules:</p> <ul style="list-style-type: none"> ▪ Only individuals who meet the requirements set forth in this user manual have permission to handle the device. ▪ The device's intended use includes its use in hazardous locations. All work with and on the device must be carried out only after the presence of an explosive atmosphere has been fully ruled out. ▪ Only use the device for the intended purpose. Never use the device for any other, potentially logical purposes. ▪ Follow all safety procedures outlined in this user manual and on the device. In particular, wear the mandatory personal protective gear. ▪ Only stay at the specified work places. ▪ Do not modify the device in any way, e. g. by removing parts or adding unapproved parts. In particular, you have no permission to modify or disable any safety contrivances. ▪ Adhere to the device maintenance intervals specified in this user manual. ▪ When replacing defective parts, only use original spare parts or manufacturer-approved standard parts.
Operator's duties opposite the employees	<p>In your capacity as the company operating the device, you must ensure the following:</p> <ul style="list-style-type: none"> ▪ All personnel must meet the requirements corresponding to their duties. ▪ All personnel must read and understand this user manual before working with/on the device. ▪ All occupational health and safety regulations that apply in your country must be complied with. ▪ Hazards resulting from specific working conditions at the location where the device is being used must be determined by means of a risk assessment and rendered avoidable by means of appropriate operating instructions. ▪ All personnel must be provided with the personal protective equipment required for their work. This personal protective equipment must be in good condition at all times.

- All personnel must wear the personal protective equipment required for their work.

Conduct in the event of accidents

The device is designed and built such that the employees can work with it without being at risk. In spite of all the precautions, accidents can happen under unfavorable circumstances. Always consult the directives of your company concerning the protection of the workforce.

3.2 Requirements concerning the workforce, personal protective gear, workplaces

Requirements concerning the workforce

Individuals tasked with handling the device must meet the following requirements:

Personnel	Responsibilities	Required qualification
Skilled person or expert	Any work on and with the device	<ul style="list-style-type: none"> ▪ Professional training and experience operating pressure equipment and systems ▪ Knowledge of the relevant standards and regulations ▪ Ability to identify and avoid dangers autonomously
Certified, independent competent person	Safety checks	<ul style="list-style-type: none"> ▪ Professional training ▪ Knowledge of the relevant standards and regulations ▪ Ability to identify and avoid dangers autonomously
Carrier	Company-to-company transport	<ul style="list-style-type: none"> ▪ Professional training and experience transporting pressure equipment and systems ▪ Knowledge of the relevant standards and regulations ▪ Ability to identify and avoid dangers autonomously ▪ Knowledge with securing hauling distances ▪ Knowledge with the use of hoisting equipment
Transportation personnel	Intra-company transport	Professional training and experience with the transport using stackers, etc.
Mechanical fitter	Mechanical installation	<ul style="list-style-type: none"> ▪ Professional training and experience operating pressure equipment and systems ▪ Knowledge of the relevant standards and regulations ▪ Ability to identify and avoid dangers autonomously
Tasked with the commissioning	<ul style="list-style-type: none"> ▪ Initial start-up ▪ Renewed start-up 	<ul style="list-style-type: none"> ▪ Professional training and experience operating pressure equipment and systems ▪ Knowledge of the relevant standards and regulations ▪ Ability to identify and avoid dangers autonomously

Personnel	Responsibilities	Required qualification
Tasked with the installation	Set-up	<ul style="list-style-type: none"> ▪ Professional training and experience operating pressure equipment and systems ▪ Knowledge of the relevant standards and regulations ▪ Ability to identify and avoid dangers autonomously
Mechanical maintenance personnel	Involving mechanical parts: <ul style="list-style-type: none"> ▪ Fault finding ▪ Maintenance ▪ Repairs 	<ul style="list-style-type: none"> ▪ Professional training and experience operating pressure equipment and systems ▪ Knowledge of the relevant standards and regulations ▪ Ability to identify and avoid dangers autonomously
Inspector	Safety check	Qualified inspector with adequate knowledge of gas pressure regulators
Tasked with the disposal	Disposal of the device	<ul style="list-style-type: none"> ▪ Professional training and experience with the disposal of pressure equipment and systems ▪ Knowledge of the relevant standards and regulations ▪ Ability to identify and avoid dangers autonomously

Requirements for the personal protective gear

Any persons handling the device must be equipped with the following personal protective gear:

Task	Required personal protective gear
Start-up, operation (including partial), cleaning, maintenance, search and remedy of errors	<ul style="list-style-type: none"> ▪ Industrial protective helmet ▪ Protective clothing ▪ Safety harness ▪ Ear protection ▪ Safety boots with protection for electrostatic discharge (ESD) ▪ Safety goggles ▪ Safety gloves

Workplace requirements

To ensure the safe handling of the device, the personnel must remain at the workplaces intended for performing their tasks.

The workplaces for performing the various tasks are at the following locations:

Task	Workplaces
<ul style="list-style-type: none"> ▪ Installation ▪ Start-up ▪ Set-up ▪ Maintenance, repairs ▪ Decommissioning 	All around the device, depending on the task

4 Basics for installing the device in a pipe

Contents

Topic	Page
Installation examples	27
Meter run characteristics	29
Operating and measuring lines	31

4.1 Installation examples

Gas pressure regulating line - example 1

Configuration:

- Direct acting gas pressure regulator (non-piloted)
- With expander without noise reduction element downstream of the gas pressure regulator

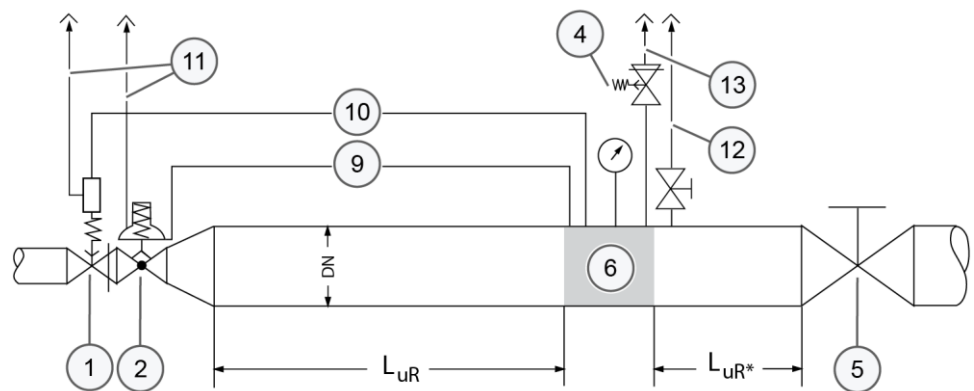

Gas pressure regulating line - example 2

Configuration:

- Indirect acting gas pressure regulator (pilot-operated)
- With expander without noise reduction element downstream of the gas pressure regulator
- Outlet pressure gauge with protection against overpressure

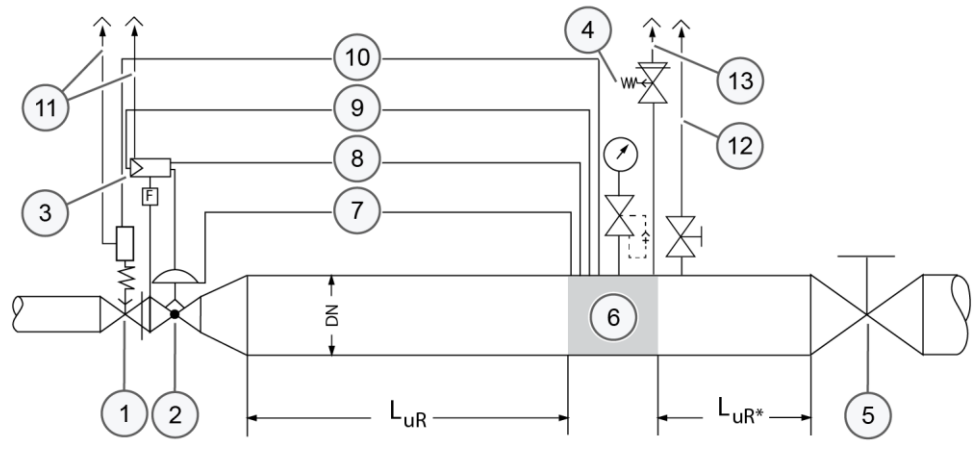

Gas pressure regulating line - example 3

Configuration:

- Indirect acting gas pressure regulator (pilot-operated)
- With expander and integrated noise reduction element
- Outlet pressure gauge with protection against overpressure

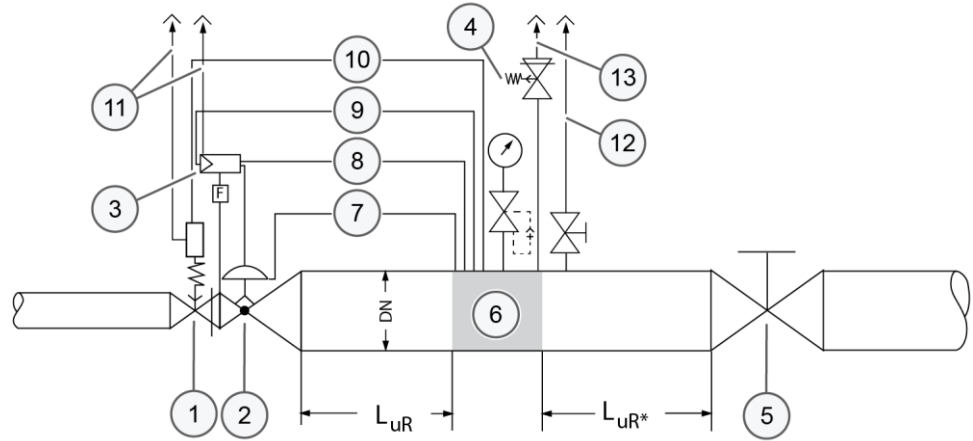

Gas pressure regulating line - example 4

Configuration:

- Indirect acting gas pressure regulator (pilot-operated)
- Indirect acting slam-shut device (pilot-operated) (two)
- With expander without noise reduction element downstream of the gas pressure regulator

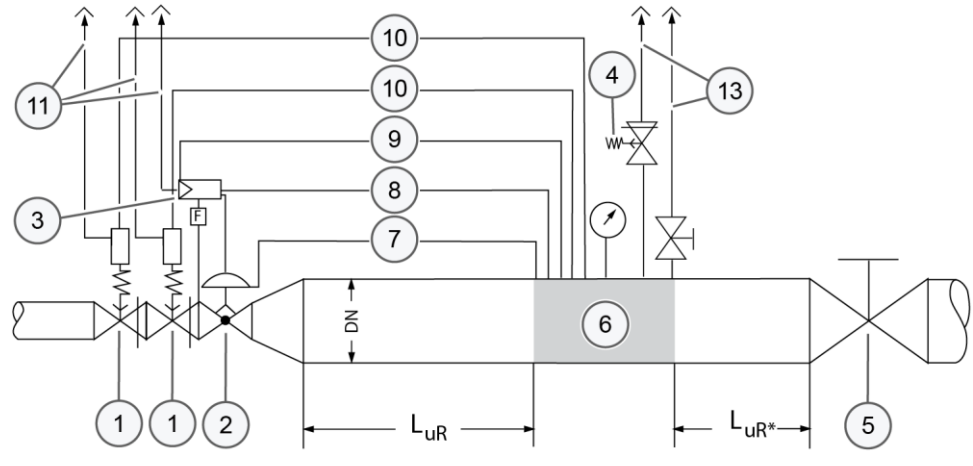

Legend

The numbers have the following meaning:

No.	Meaning
1	Safety Shut-Off Valve
2	Gas pressure regulator
3	Pilot
4	Safety relief valve
5	Outlet stop valve armature
6	Sensing point for connection lines (gray area)
7	Feedback line
8	Discharging line
9	Gas pressure regulator measuring line
10	Slam-shut device measuring line
11	Vent line
12	Relief line
13	Blowdown line

Following is the meaning of the acronyms:

Acr.	Meaning
DN	Nominal size of pipe
L _{UR}	Undisturbed length of pipe

* Shut-off device with undisturbed flow pattern (ball valve) can be incorporated

4.2 Meter run characteristics

Standards used as a basis

The following recommendations are based on the measuring line connection conditions set forth in standards (DIN) EN 334 and (DIN) EN 14382. The company operating the system is the sole party responsible for the meter run working properly.

Conditions for the meter run

- A pipe area with a steady flow pattern must be selected for the sensing point. There must not be any components that disturb the flow directly upstream and downstream of the sensing point, e.g., orifice plates, expanders, bends, junctions, shut-off devices, etc.
- The flow rate at the sensing point should not exceed approx. 25 m/s, depending on the system conditions.
- In the case of specific system circuits (such as gas regulating lines for gas engines) and in the case of gas burners, flow rates higher than 25 m/s may be allowed following consultation with the manufacturer.
- Within a low-pressure range of up to approx. 250 mbar, a maximum flow rate of approx. 15 to 20 m/s is recommended at the sensing point. On a case-by-case basis, and following consultation with the manufacturer, even lower flow rates may be allowed.

Upstream of the sensing point

Depending on the specific system design, the L_{UR} lengths of the undisturbed pipes upstream of the sensing point must be $(2.5 \text{ to } 5) \times \text{DN}$ of the pipe, with the specifics depending on the gas pressure regulator model and whether or not there is a pipe expander downstream:

If ...	and...	then...
A gas pressure regulator with an expander that is part of the device is used	The nominal size of the pipe is equal to the outlet-side nominal size of the gas pressure regulator	$L_{UR} \text{ min. } 2.5 \times \text{DN}$
	The nominal size of the pipe is the next larger standard nominal size	$L_{UR} \text{ min. } 3 \times \text{DN}$
	The nominal size of the pipe is two standard nominal size increments larger	$L_{UR} \text{ min. } 4 \times \text{DN}$
	The nominal size of the pipe is more than two standard nominal size increments larger	$L_{UR} \text{ min. } 5 \times \text{DN}$
A gas pressure regulator with the same outlet nominal size as the inlet nominal size is used	The nominal size of the pipe is the next larger standard nominal size	$L_{UR} \text{ min. } 4 \times \text{DN}$
	The nominal size of the pipe is two standard nominal size increments larger	$L_{UR} \text{ min. } 5 \times \text{DN}$

Downstream of the sensing point

Depending on the specific system design, the L_{UR} lengths of the undisturbed pipes downstream of the sensing point must be $(1.5 \text{ to } 4) \times \text{DN}$ of the pipe:

Undisturbed length of pipe	for
$L_{UR} \text{ min. } 1.5 \times \text{DN}$	Thermowells
$L_{UR} \text{ min. } 1.5 \times \text{DN}$	Reducers and expanders, depending on the specific system conditions
$L_{UR} \text{ min. } 3 \times \text{DN}$	Shut-off devices (gate valves, check valves, and reduced bore ball valves)
$L_{UR} \text{ min. } 4 \times \text{DN}$	Tees

Details

- Shut-off devices with an undisturbed flow pattern (such as full bore ball valves) and, if applicable, pipe bends (depending on the design) are considered to be non-disturbing elements in terms of measuring line connections.
- For gas meters (turbine gas meters including quantometers, ultrasonic gas meters, and vortex flow meters, but NOT rotary piston gas meters), there are no restrictions in terms of measuring line configurations, as these meters are not considered to be flow-disturbing within this context.
- The following applies to rotary piston gas meters: Minimum distance between gas pressure regulator or reducer / expander and gas meter: $L_{UR} \text{ min. } 3 \times \text{DN}$.
- Measuring line connections downstream of gas meters must be at a distance of $L_{UR} \text{ min. } 2 \times \text{DN}$.
- If shut-off valves are used (reduced bore), the recommended distance downstream of a measuring line is $L_{UR} \text{ min. } 3 \times \text{DN}$.
- Gas meter pressure losses must be taken into account based on system conditions if applicable.

4.3 Operating and measuring lines

Connection lines between device and gas regulating line

The lines must be arranged and sized in such a way that the devices' intended function will be ensured.

- **Measuring line**

- The measuring line transmits the pressure process value from the sensing point to the measuring diaphragm of a controller or the pilot of a gas pressure regulator or safety relief valve or to the measuring diaphragm of the monitoring device of a slam-shut device. It needs to be connected to the pipe sideways or upwards separately for each device. In the case of safety equipment, the measuring line must be connected upstream of the first outlet-side shut-off device in such a way that it cannot be shut off. If the measuring line is additionally connected downstream of the first outlet-side shut-off device, 3-way ball valves with negative overlap must be used for switching. These ball valves do not have a valve position in which both measuring lines can be fully closed at the same time.

- **Vent line**

- The vent line is used to connect a measuring diaphragm to the atmosphere. If the measuring unit becomes damaged (e.g., diaphragm rupture), it can start conveying gas. Under certain operating conditions, and following consultation with the manufacturer, vent lines can be omitted if vent valves (HON 915) or safety diaphragm configurations can be used instead.

- **Blowdown line**

- The blowdown line in a safety relief valve is used to divert gas (leaking gas, for example) into the atmosphere.

Grouping vent lines or blowdown lines (into a header) is permissible if it does not have a negative impact on the individual devices' operation. Within this context, it is recommended to have the cross-sectional area of the header be at least five times as large as the total of the individual lines' cross-sectional areas.

For primary slam-shut devices, it is recommended to route the slam-shut devices' vent lines separately. Vent lines must not be grouped together with blowdown lines.

- **Discharging line**

- When using indirect acting (pilot-operated) slam-shut devices, the discharging line is used to divert the exhaust gas from the pilot into the system's outlet chamber. On certain devices, the discharging line will be grouped with the feedback line.

- **Feedback line**

- When using indirect acting (pilot-operated) slam-shut devices, the feedback line is used to return the outlet pressure to the actuator.

5 Transport and installation

Contents

Topic	Page
Transporting the gas pressure regulator	32
Installing the gas pressure regulator	33
Installing the device connections	35
Checking the system for leaks	36

5.1 Transporting the gas pressure regulator

Heavy transport units



Risk of serious injury posed by heavy loads when using cranes for transportation

Transporting heavy devices or components with a crane may result in serious impact and crush injuries if the loads start moving in an uncontrolled manner.

- ⇒ Loads may only be transported with a crane by a duly qualified person.
- ⇒ Markings and information about the center of gravity of the load (if applicable) must be observed.
- ⇒ Loads may only be moved under supervision.

Suspended loads



Risk of serious injury in the event that load handling attachments break while holding a suspended load

Heavy loads picked up or transported with hoisting and slinging gear may result in serious impact and crush injuries if the load handling attachments fail.

- ⇒ Only fasten the device at the positions intended for the transport.
- ⇒ The load-bearing capacity of the appropriate hoisting equipment must correspond at least to the weight of the load to be transported.
- ⇒ Always stand clear of suspended loads.
- ⇒ Ensure that no person is within the danger zone.

Selecting the hoisting equipment and slings

A mobile workshop crane is suitable for use as hoisting equipment.

The following are adequate for use as slings:

- Ropes
- Belts
- Chains

The hoisting equipment and slings must meet the following criteria:

- The load capacity must be sufficient for the total weight of the equipment being transported.
- The hoisting height is adequate for the mounting position at the installation site.

Preparing for transportation

Make sure that the following requirements are met before transportation:

- You have seen and taken into account all instructions on the packaging regarding the orientation of the packed device, the center of gravity, and attachment points.
- The transport route is clear of obstacles and other barriers, and there is enough space available for the dimensions of the packed device and the handling equipment. Make sure to measure all of the package's dimensions!
- The transport route will be able to handle the load exerted by the total weight of the handling equipment and the load being transported.

- There is enough space for unpacking and installing the device at the installation location.

Transporting the device

Proceed as follows:

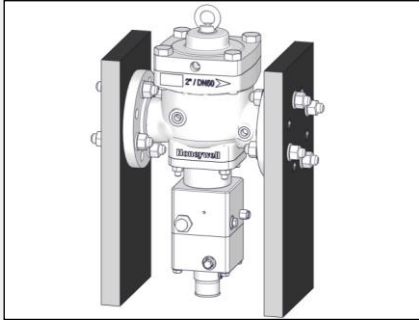
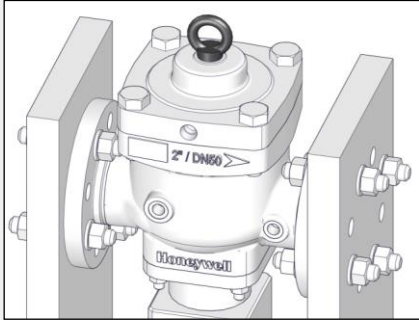
Figure	Step	Description
	1	Leave the flange protective plates on the HON 5020 during transport.
	2	Hook the sling into the eye bolt.
	3	Lift the device. Slowly and carefully transport the device to the location where it will be installed.

If the travel indication option is present, proceed as follows:

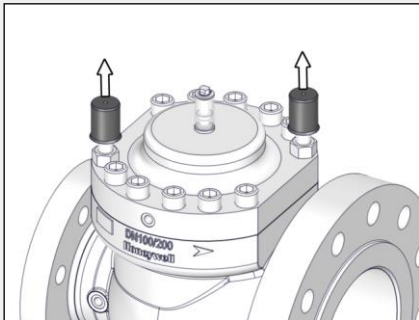
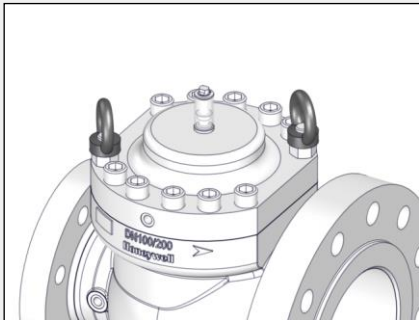
	1	Remove the protective caps.
	2	Install the ring bolts included in delivery and attach the slings to the ring bolts.
	3	Lift the HON 5020. Slowly and carefully transport the HON 5020 to the location where it will be installed.

5.2 Installing the gas pressure regulator

Preparing the materials

Prepare the following materials:

- Flange gaskets

- Threaded bolts
- Washers
- Nuts

The quantity and size are dependent on the following criteria:

- Design and size of the flange

Assessing the situation

Assess the installation situation.

The numbers have the following meaning:

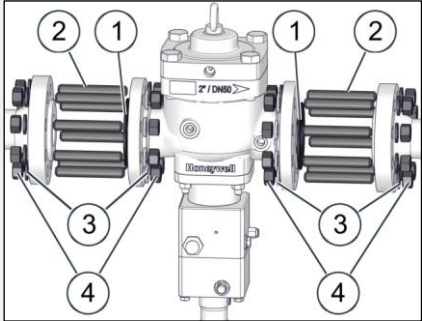
Figure	No.	Meaning
	1	Flange gasket
	2	Threaded bolts
	3	Washer
	4	Nut

Mounting the device

Proceed as follows:

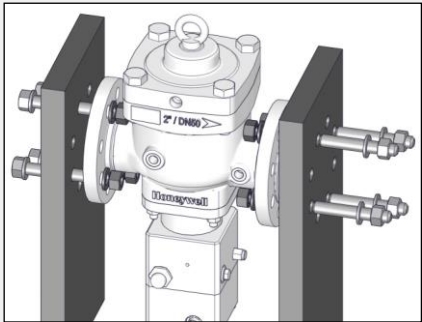
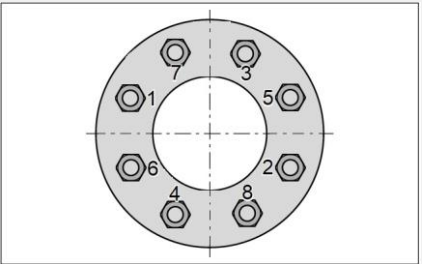
Figure	Step	Description
	1	Remove the protective plates from the flange.
	2	Transport the device to the location where it will be installed. <ul style="list-style-type: none"> ▪ The device needs to be installed in the piping in a horizontal and level position. If you want to use a different installation position, consult with the manufacturer first. ▪ Pay attention to the direction of flow for the gaseous fluid as marked on the body.
	3	Secure and support the device's position in such a way that the device can be installed in the piping without any stress and that the piping's weight will be supported as well.
	4	Install the flange gaskets.
	5	Screw down the flange crosswise in the specified order. When doing so, make sure to observe the torques specified by the flange gaskets' manufacturer.

Final inspection

Conduct a final inspection to check whether the following criteria are met:

- All screwed connections on the device and supply lines are securely fastened.

If ...	then ...
at least one criterion is not met	you should correct the error before proceeding with the next task.
all criteria are met	you may proceed with the next task.

Next task

Proceed as follows:

Installing the device connections

5.3 Installing the device connections

Operating and measuring lines that are pre-installed and that need to be installed

The figure below shows a version of the HON-5020-with-SAV actuator assembly in combination with a pilot and a monitoring device.

Some of the measuring impulse lines will come pre-installed:

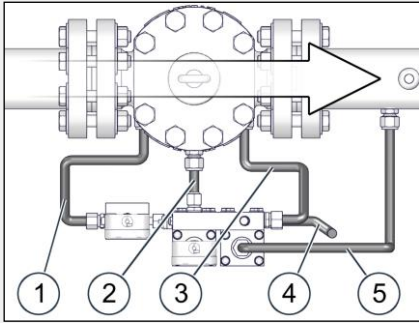
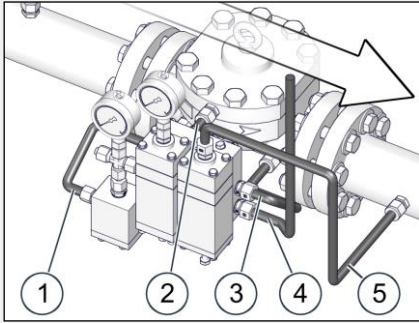
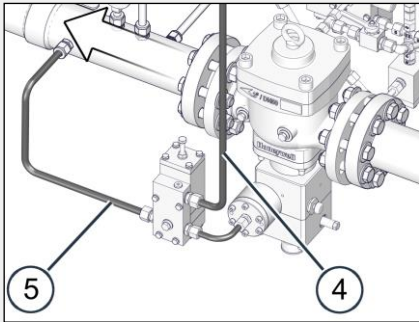
Figure	No.	Designation, category, installation condition
	1	Inlet pressure line, operating line, pre-installed
	2	Motorization line, operating line, pre-installed
	3	Outlet pressure line, operating line, pre-installed
	4	Vent line, operating line, needs to be installed
	5	Outlet pressure measuring line, measuring line/operating line, needs to be installed
		

Preparing the materials

Prepare the following materials:

- Pipes, connecting pieces, and fittings as per the specifications in the *Technical specifications* (see page 18)
- Shut-off devices for the operating and measuring lines, as well as other accessories, as required, as per the *Basics for installing the device in a pipe* (see page 27) section.

Installing the operating and measuring lines

The installation of the operating and measuring lines depends on the local conditions and the gas regulating line in which the gas pressure regulator is being used. Please refer to the *Basics for installing the device in a pipe* (see page 27) section for more information on what needs to be ensured without fail in the corresponding design and implementation.

Final checks

Conduct a final inspection to check whether the following criteria are met:

- All threaded joints on the connection lines have been checked to ensure that they have a secure fit.

If ...	then ...
at least one criterion is not met	you should correct the error before proceeding with the next task.
all criteria are met	you may proceed with the next task.

Next task

Proceed as follows:

Checking the system for leaks

5.4 Checking the system for leaks

Leak test conducted by the manufacturer

Prior to delivery, the manufacturer conducted a pressure and leak test on the gas pressure regulator as specified in DIN EN 334.

Leak test at the set-up location (in Germany)

The gas pressure regulator installed in the system must be subjected to a leak test at the setup location as follows:

Normative basis	DVGW Code of Practice G 491
Test method	Bubble test method
Test medium	Air or inert gas
Scope of the test	All detachable pipe joints
Test equipment	Foam-generating leakage medium
Test pressure	1.1 times the operating pressure (MOP)

Leak test at the set-up location (in other countries)

The device installed into the system must undergo a leak test at the set-up location in accordance with applicable international and national standards.

Pressurized parts



Risk of serious injury posed by pressurized components moving in an uncontrolled manner when handled improperly.

If not handled properly or in the event of a defect, gas can escape from pressurized components under high pressure and cause serious injuries and even death. Before you start working on these components:

- ⇒ Close all connections leading to the gas-carrying line.
- ⇒ Establish a depressurized status. Residual amounts of energy must be depressurized as well.

Pressurized parts



Risk of injury posed by bursting parts in the event that they are subjected to pressure in the wrong direction

The device has been designed for a specific direction of flow, which is labeled on the device. Subjecting the device to pressure in the wrong direction may result in serious injury caused by bursting parts.

- ⇒ Pressurize the system only on the inlet side.

Details about the operating pressure can be found in the technical specifications.

Technical specifications (see page 18)

Test configuration

The test setup is as follows (schematic diagram, using the two-stage HON 630 pilot with a diaphragm assembly and an HON 670 / 671 monitoring device as a reference):

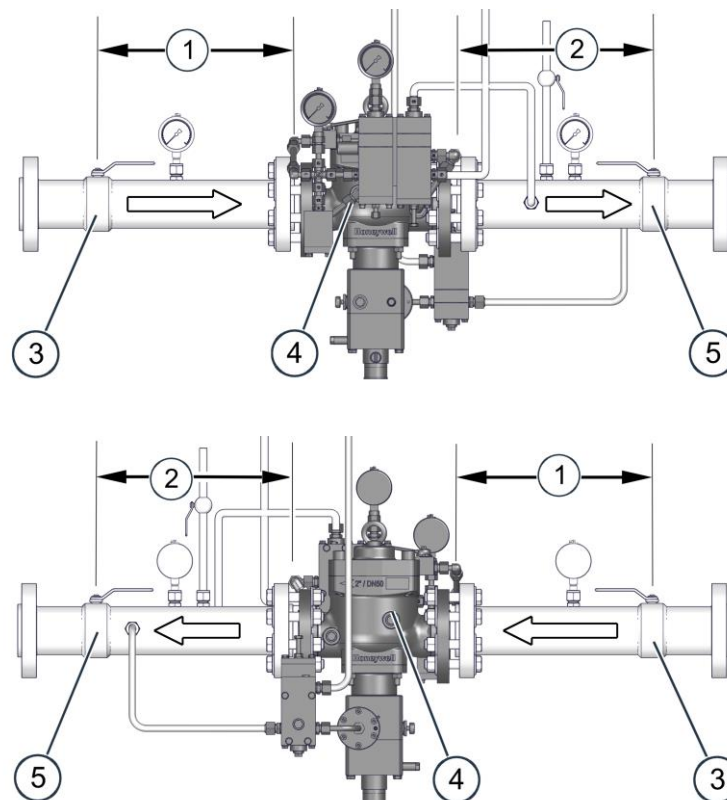

The numbers have the following meaning:

No.	Meaning
1	Inlet chamber
2	Outlet chamber
3	Inlet stop valve armature
4	Gas pressure regulator
5	Outlet stop valve armature

Checking the system for leaks

Proceed as follows:

Step	Description
1	Slowly close the outlet stop valve armature.
2	Apply the test medium to all detachable pipe joints.
3	Observe the test medium on all detachable pipe joints for several minutes.

If ...	then ...
no foam or bubbles are formed	<ul style="list-style-type: none"> ▪ the system is leak-proof. ▪ the system may be put into operation.
foam or bubbles are formed	<ul style="list-style-type: none"> ▪ the affected pipe joint is leaking. ▪ the system may not be put into operation. ▪ Proceed with step 4.

Step	Description
4	Slowly close the inlet stop valve armature.
5	Depressurize the inlet chamber and the outlet chamber.
6	Seal the leaking pipe joints.
7	Repeat the leak test starting with step 1.

6 Adjusting the settings of the device

Contents

Topic	Page
Adjusting the loading pressure	39
Adjusting the control stage setpoint	40
Adjusting the amplifying valve	41
Setting and commissioning the safety shut-off valve	43

6.1 Adjusting the loading pressure

Default loading pressure setting

The manufacturer will have already preset the loading pressure based on the customer's specifications. By default, the loading pressure will be set to 5 - 10 bar over outlet pressure p_d . For the current loading pressure, please check the load limiting stage pressure gauge reading.

Adjusting the loading pressure

Proceed as follows:

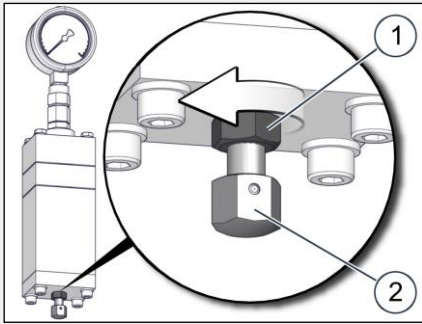
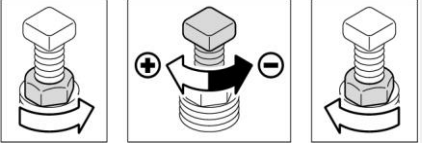
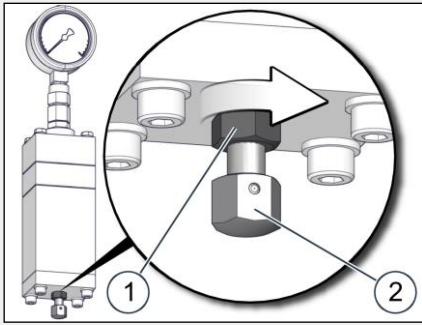
Figure	Step	Description
	1	Unscrew the lock nut (1) on the set screw (2) located on the underside of the pilot's load limiting stage.
	2	Turn the set screw until the load limiting stage pressure gauge shows the setpoint you want: <ul style="list-style-type: none"> ▪ Counterclockwise (-) to loosen the pilot spring or <ul style="list-style-type: none"> ▪ Clockwise (+) to tighten the pilot spring
	3	Tighten the lock nut (1) to secure the set screw (2) setting.

6.2 Adjusting the control stage setpoint

Requirements

Make sure that the following requirements are met:

- The load limiting stage is preset to a default value for the loading pressure (usually 5 - 10 bar over the setpoint for outlet pressure p_d).
- The inlet and outlet shut-off devices for the gas regulating line section with the gas pressure regulator are closed.
- The pressure in the outlet chamber downstream of the gas pressure regulator is lower than the setpoint for outlet pressure p_d .
- The shut-off devices for the blowdown lines are closed.
- The inlet pressure is present upstream of the inlet shut-off device.

Adjusting the control stage setpoint

Proceed as follows:

Figure	Step	Description
	1	Unscrew the lock nut (1) on the set screw (2) located on the underside of the pilot's control stage.
	2	Loosen the set screw (2) until the tension in the pilot spring has been relieved.
	3	Open the inlet shut-off device.
	4	Turn the set screw in small increments until the pressure gauge in the outlet chamber shows the setpoint for the correct outlet pressure p_d . Turn the set screw: <ul style="list-style-type: none"> ▪ Clockwise (+) to tighten the pilot spring or ▪ Counterclockwise (-) to loosen the pilot spring
	5	Open the outlet shut-off device.

Figure	Step	Description
	6	Wait a few minutes and check the reading for outlet pressure p_d in the outlet chamber.
	7	If necessary, keep adjusting the set screw setting until you get the right outlet pressure p_d .
	8	Tighten the lock nut (1) to secure the set screw (2) setting.

6.3 Adjusting the amplifying valve

Control behavior changes achieved by adjusting the amplifying valve

The following changes in the gas pressure regulator's control behavior can be achieved by adjusting the amplifying valve on the pilot:

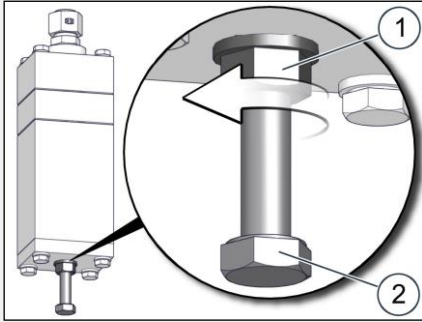
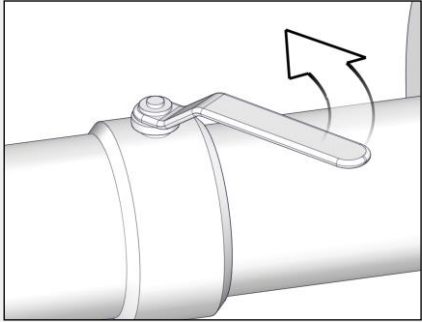
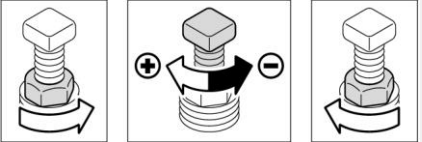
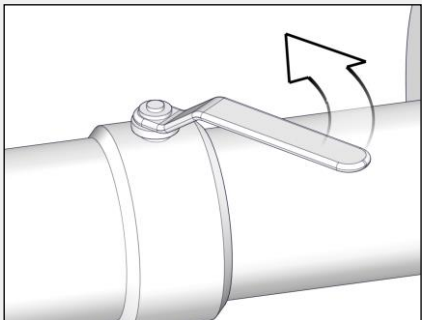
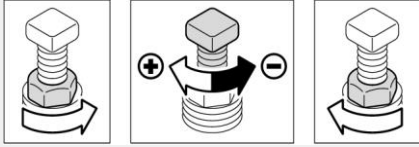
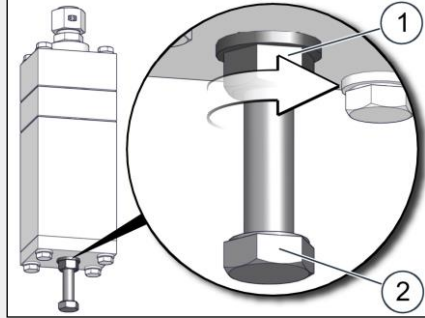
- If the gas pressure regulator exhibits a sluggish response to changes in the manipulated variable, the response times can be shortened.
- If the gas pressure regulator's dynamic response to changes in the manipulated variable is too fast and this results in oscillations, the gas pressure regulator's response can be slowed down.

Adjusting the amplifying valve

Proceed as follows:

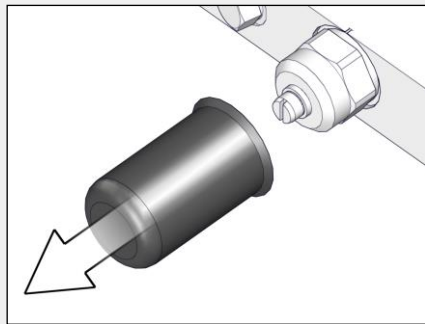
Figure	Step	Description
	1	Remove the cap from the amplifying valve.

If ...	then ...
You want to speed up the actuator assembly's response	Carry out step 2a and then continue to step 3.
You want to slow down the actuator assembly's response, e.g., in the case that there are oscillations	Carry out step 2b and then continue to step 3.

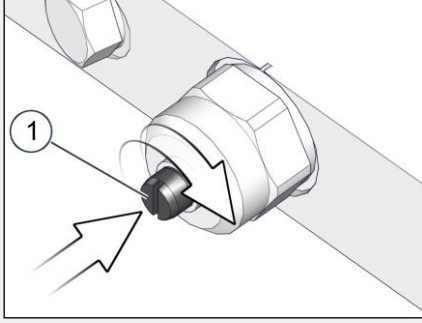
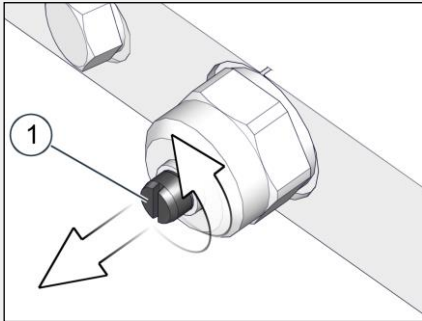
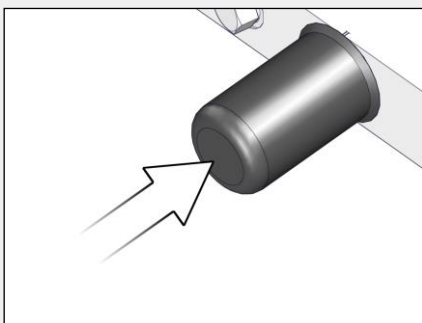
Figure	Step	Description
	<p>2a</p>	<p>Use a flat-blade screwdriver to screw the spindle (1) deeper into the sleeve turn by turn while monitoring the actuator assembly's control behavior. As soon as you achieve the actuator assembly response you want, stop changing the spindle's position.</p>
	<p>2b</p>	<p>Use a flat-blade screwdriver to unscrew the spindle (1) out from the sleeve turn by turn while monitoring the actuator assembly's control behavior. As soon as you achieve the actuator assembly response you want, stop changing the spindle's position.</p>
	<p>3</p>	<p>Put the amplifying valve cap back in place.</p>

6.4 Setting and commissioning the safety shut-off valve

Contents

Topic	Page
How the integrated safety shut-off valve works	43
Installing the test layout	44
Checking the SSV for tightness	46
Completing the function check	48
Closing SSV flaps manually	48
Opening the valve	49
Faults and anomalies	54

6.4.1 How the integrated safety shut-off valve works

How the integrated safety shut-off valve works

At the same time as regulating using the pilot, the gas pressure to be monitored is applied at the relevant controller. The controller compares the current gas pressure to the preset trip pressure. Depending on the controller, exceeding and/or falling below the set trip pressure will trip the control unit, leading to the safety shut-off valve closing. The closing mechanisms differ depending on the size of the device. The valve plate shuts off the inlet pressure zone in the main valve and stops any further gas flow.

The safety shut-off valve cannot be reopened until the gas pressure in the downstream system has been returned towards the setpoint value range by the relocking differential. The safety shut-off valve is opened manually.

Re-engage differential



The term “re-engage differential” (Δp_o and Δp_u) refers to the minimum pressure differential between the upper response value (p_{so}) and the lower response value (p_{su}). This re-engage differential specifies the minimum value by which the pressure needs to decrease towards the setpoint (after the safety shut-off valve has closed) so that it will be possible to reopen the safety shut-off valve manually.

Illustration	No.	Meaning
	1	Upper response pressure p_{so}
	2	Re-engage differential Δp_u (pressure drop required in order to be able to re-engage after a shut-off caused by excess pressure)
	3	Pressure range within which it is possible for the safety shut-off valve to engage safely
	4	Re-engage differential Δp_o (pressure increase required in order to be able to re-engage after a shut-off caused by insufficient pressure)
	5	Lower response pressure p_{su}

The relocking differential depends on the controller and is described in the controller documentation.

Special tools

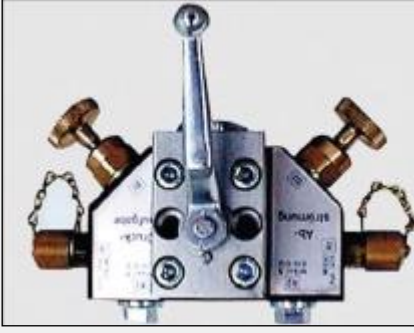
In addition to standard tools, keep the following test valves available:

Illustration	Designation
	Test valve HON 916
	Push-button valve HON 911a
	Test valve HON 914

6.4.2 Installing the test layout

Installing the test layout

Install the test layout as follows (principle diagram):

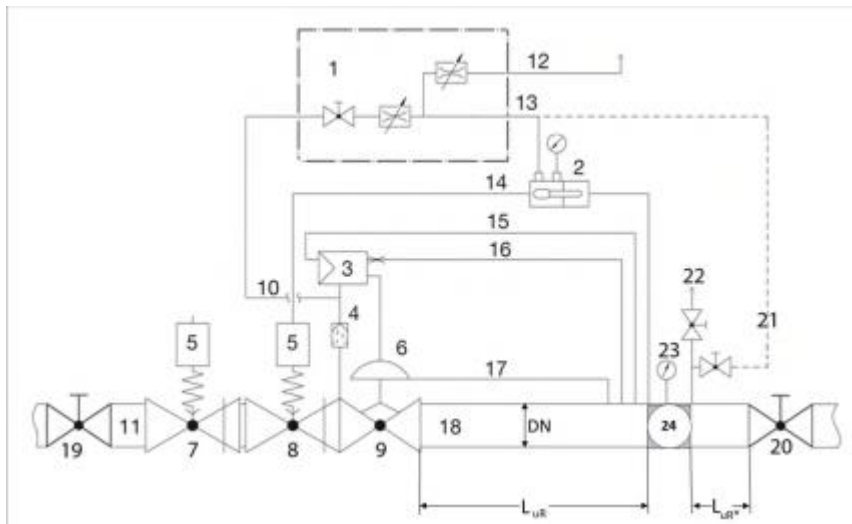

The numbers mean as follows:

No.	Designation
1	Test combination HON 916
2	Push-button valve HON 911a or test valve HON 914 (is a permanent fixture in the station structure and remains in the pipework)
3	Pilot
4	Filter
5	SSV controller
6	Actuator
7	SSV 1
8	SSV 2
9	Gas pressure regulator
10	Outlet pressurization test line
11	Inlet line
12	Discharge to the open air
13	Pressurization point
14	SSV sensing line
15	Gas pressure regulator sensing line
16	Discharge line
17	Return line
18	Outlet line
19	Inlet stop valve
20	Outlet stop valve
21	SSV testing connection (without HON 916/914/911)
22	Depressurization line
23	Pressure gauge
24	Sensing point for connection lines (area coloured grey)

The abbreviations mean as follows:

Abbreviation	Meaning
DN	Nominal diameter of the pipework
L _{UR}	Length of the undisturbed pipework

6.4.3 Checking the SSV for tightness

Requirements

Ensure that the following requirements are satisfied:

- The outlet stop valve is closed.
- The inlet stop valve is closed.
- The section between the inlet and outlet stop valves is depressurized.
- The SSV is closed.

Checking the SSV for tightness

Proceed as follows:

Step	Description
1	Slowly open the inlet stop valve. Result: the inlet pressure is applied to the SSV.
2	Check the tightness of the SSV seat (for example, using a connected master gauge).
3	If the SSV is tight, equalize the pressure using the pressure equalization device on the SSV.
4	Open the SSV. Result: the inlet pressure is applied to the outlet.
5	Set the outlet pressure on the gas pressure regulator (refer to the operating instructions for your gas pressure regulator).

Next task

Continue as follows:

- Opening the valve

Setting the upper trip pressure

Proceed as follows:

Step	Description
1	Connect the ball valves to test valves HON 916 and HON 914/911a.
2	Apply the inlet pressure and open the ball valve on test combination HON 916.
3	On test combination HON 916: adjust the pressure changing rate using the appropriate supply or discharge dosing valve.
4	Actuate the push-button valve HON 911a or close the ball valve on test valve HON 914.
5	Find the trip pressure on the SSV controller and, if necessary, adjust the trip pressure by turning the adjusting screw.
6	Check the trip pressure by switching the SSV several times. Note: check the relocking differential when you relock the SSV. If an SSV closes during setting work, the closed SSV must be reopened before the next step. If the SSV cannot be relocked, the required pressure drop is too low to relock the valve after an overpressure shut-off.

Continue as follows:

If...	then...
the trip pressure is equal to the setpoint pressure	the setting work is complete. Continue with step 7.
the trip pressure is higher than the setpoint pressure	correct the pressure by turning the setpoint adjusting screw anticlockwise. Repeat steps 1 to 6.
the trip pressure is lower than the setpoint pressure	correct the pressure by turning the setpoint adjusting screw clockwise. Repeat steps 1 to 6.

Step	Description
7	Apply the outlet pressure (closing pressure of the gas pressure regulator) to the controller.
8	Tighten the locking nut on the setpoint adjusting screw on the SSV. Result: the setting work is complete.
9	Remove the test device including the test hoses.
10	Open the SSV. Result: the SSV is ready for operation.

Setting the lower trip pressure

Proceed as follows:

Step	Description
1	Close the ball valve on test valve HON 916.
2	Open the ball valve on test valve HON 914.
3	Open the depressurization line (22).
4	Reduce the outlet pressure until the lower trip pressure is reached on the SSV.
5	Check the trip pressure by switching the SSV several times. Note: check the relocking differential when you relock the SSV. If an SSV closes during setting work, the closed SSV must be reopened before the next step. If the SSV cannot be relocked, the required pressure increase is too low to relock the valve after an underpressure shut-off.

Continue as follows:

If...	then...
the trip pressure is equal to the setpoint pressure	the setting work is complete. Continue with step 6.
the trip pressure is higher than the setpoint pressure	correct the pressure by turning the setpoint adjusting screw anticlockwise. Repeat steps 1 to 5.
the trip pressure is lower than the setpoint pressure	correct the pressure by turning the setpoint adjusting screw clockwise. Repeat steps 1 to 5.

Step	Description
6	Close the depressurization line (22).
7	Tighten the locking nut on the setpoint adjusting screw on the SSV. Result: the setting work is complete.
8	Remove the test device including the test hoses.
9	Open the SSV. Result: the SSV is ready for operation.

6.4.4 Completing the function check

Requirements

Ensure that the following requirements are satisfied:

- The outlet stop valve is closed.
- The inlet stop valve is closed.
- The section between the inlet and outlet stop valves is depressurized.
- The SSV is closed.

Completing the function check

Proceed as follows:

Step	Description
1	Using the test layout: establish the trip pressure at which the SSV switches. To do this, proceed as described in Setting the trip pressure.
2	Repeat step 1 several times to confirm the value.

Continue as follows:

If...	then...
the SSV has closed when the trip pressure setpoint is reached	the function check is complete. The station is ready for operation. Next step: Commissioning the device
the SSV has closed at a different trip pressure than the setpoint value or has not closed at all	the trip pressure must be set correctly on the relevant SSV. The station is not ready for operation. Next step: Setting the trip pressure

6.4.5 Closing SSV flaps manually

Reasons for closing the SSV flaps manually

The valve flaps may have to be closed manually in the following circumstances:

- If there is any imminent danger
- If the SSV requires maintenance work
- If the station is to be decommissioned

Manual release on nominal size 1" (DN 25)

Manual release is not a standard function on the 1" (DN 25) version.

Manual release on nominal size 2" (DN50); 3" (DN80); 4" (DN100)

Proceed as follows:

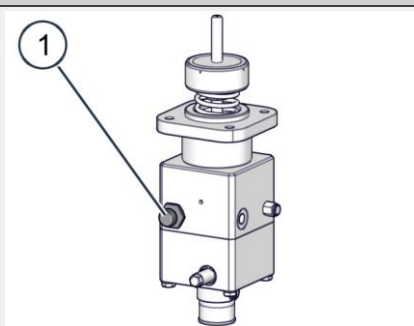
Illustration	Description
	<p>The release button on the control unit (HON 5020 SSV 2" (DN 50), 3" (DN 80) and 4" (DN 100)) can be used to close the SSV manually.</p> <p>Pressing the release button once releases the locking mechanism on the SSV without affecting the pneumatic pressure on the SSV controller.</p> <p>For further details of opening the SSV controller, see section:</p>

Manual release on nominal size 6" (DN 150)

Proceed as follows:

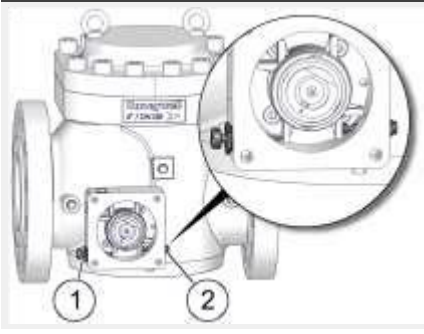
Illustration	Description
	<p>The release button on the control unit (HON 5020 SSV 6" (DN 150)) can be used to close the SSV manually. Pressing the release button once releases the locking mechanism on the SSV without affecting the pneumatic pressure on the SSV controller.</p> <p>The release button (1) is located on the body of the control unit.</p> <p>For further details of opening the SSV controller, see section:</p>

6.4.6 Opening the valve

Requirements

Ensure that the following requirements are satisfied:

- The cause for closing the device has been rectified.
- The pressure in the station is within the setpoint pressure range.

Opening the control unit on version HON 5020 SSV 1" (DN 25) with HON 673

HON 5020 SSV with controller version:

- HON673 (K1a)
- HON 673 (K2a/1)
- HON 673 (K2a/2)

Proceed as follows:

Illustration	Step	Description
	<p>1</p>	<p>Actuate the pre-purging valve (item 7). Press and hold the button until the pressure differential between the inlet and outlet has been fully equalized.</p>
	<p>2</p>	<p>Unscrew the cover (1) from the controller.</p>

Illustration	Step	Description
	<p>3</p>	<p>Place the cover (1) onto the housing the other way round and secure the cover to the switch stem (2).</p>
	<p>4</p>	<p>Carefully pull the cover (1) as far as possible using the switch stem (locking position) and then allow the switch stem to slowly slide back into place. Result: the controller is locked.</p>
	<p>5</p>	<p>Fit the cover in its original position. Result: the SSV is ready for operation.</p>

**Opening the control unit
on version HON 5020 SSV
1" (DN 25) with
HON 670/671**

HON 5020 SSV with controller version:

- HON 670 (K16)
- HON 670 (K18)
- HON 670/671 (K16/K17)
- HON 670/671 (K18/K19)

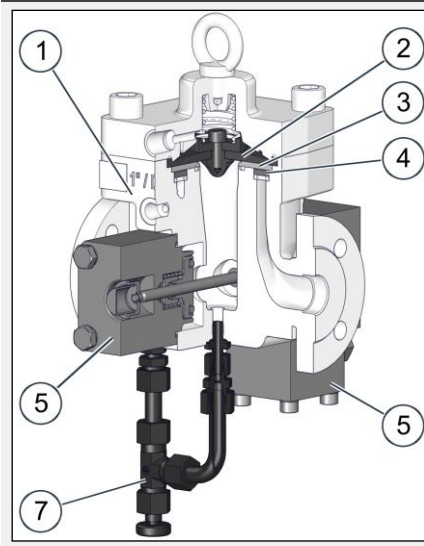
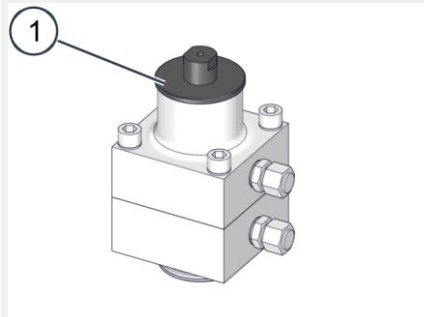
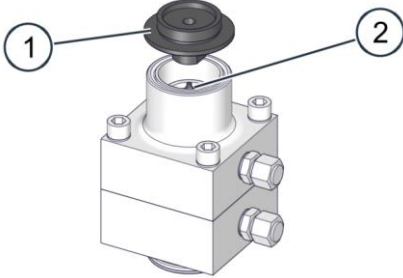
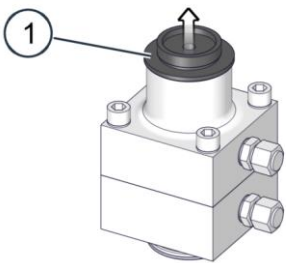
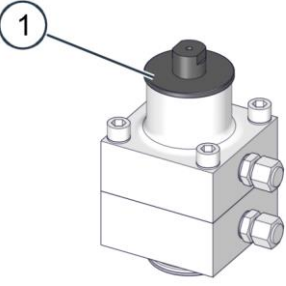
Proceed as follows:

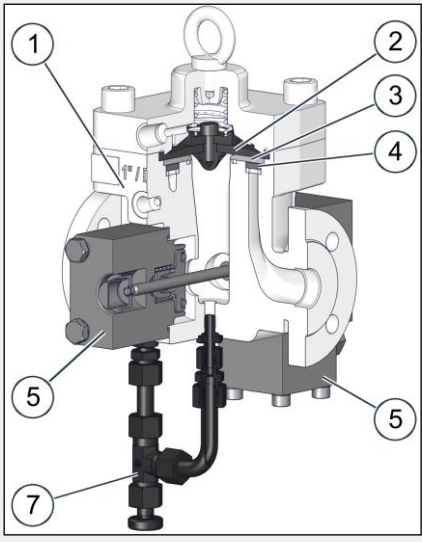
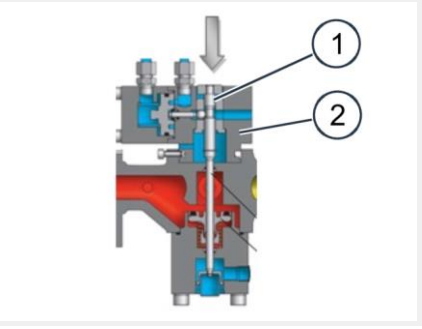
Illustration	Step	Description
	<p>1</p>	<p>Actuate the pre-purging valve (item 7). Press and hold the button until the pressure differential between the inlet and outlet has been fully equalized.</p>
	<p>2</p>	<p>Press the valve stem back into the body of the control unit using the switch stem (1) which projects out of the housing (2). Result: the controller is locked. Result: the SSV is ready for operation.</p>

Opening the control unit on version HON 5020 SAV 2" (DN50); 3" (DN80); 4" (DN100)

The pre-purging valve is integrated in the control unit on the 2" (DN 50), 3" (DN 80) and 4" (DN 100) versions. The pre-purging process takes place during the opening process on these versions. It is therefore important to open the SSV slowly.

HON 5020 SSV with controller version:

- HON 670 (K16)
- HON 670 (K18)
- HON 670/671 (K16/K17)
- HON 670/671 (K18/K19)
- HON 670/671 (K16/K11a/1)
- HON 671 (K17)
- HON 671 (K19)
- HON 672 (K10a)
- HON 672 (K11a/1)
- HON 672 (K11a/2)

Proceed as follows:

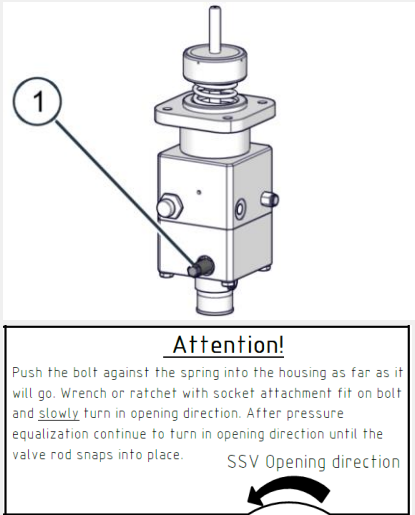
Illustration	Step	Description
 <p>Attention! Push the bolt against the spring into the housing as far as it will go. Wrench or ratchet with socket attachment fit on bolt and <u>slowly</u> turn in opening direction. After pressure equalization continue to turn in opening direction until the valve rod snaps into place.</p> <p>SSV Opening direction</p>	<p>1</p>	<p>Place an open-ended spanner (A/F 13) (1/2") or a ratchet tool on the hexagon bolt. Move the bolt to and fro slightly and use the tool to press the bolt into the housing until it strikes the mechanical stop. Slowly turn the bolt using the tool in the opening direction shown on the device. (Refer to the information sticker on the device above the hexagon bolt for this purpose) Turn it initially through an angle of around 15°; you will hear a hissing noise. The station is now being pre-purged. Wait for a moment until the pressure differential between the inlet and outlet has been fully equalized. Now continue to turn the bolt in the opening direction until the SSV locks. Now take the tool off the bolt. The bolt should jump fully back out of the housing.</p> <p>2</p> <p>If the valve does not lock, repeat step 1 and recheck the requirements for opening the valve.</p>

**Opening the control unit
on version
HON 5020 SAV 6”
(DN150)**

HON 5020 SSV with controller version:

- HON 670 (K16)
- HON 670 (K18)
- HON 670/671 (K16/K17)
- HON 670/671 (K18/K19)
- HON 670/671 (K16/K11a/1)
- HON 671 (K17)
- HON 671 (K19)
- HON 672 (K10a)
- HON 672 (K11a/1)
- HON 672 (K11a/2)

Proceed as follows:

Illustration	Step	Description
	<p>1</p>	<p>Actuate the pre-purging valve (item 1). Press and hold the lever until the pressure differential between the inlet and outlet has been fully equalized.</p>
	<p>2</p>	<p>Pull the relocking lever (1) against the slight resistance downwards out of the spring housing.</p>
	<p>3</p>	<p>Place the relocking lever (1) in the mounting in the opening element (2). Turn the relocking lever (1) anticlockwise until it reaches the palpable locking point of the valve flap.</p> <p>If the valve does not lock, repeat step 1 and recheck the requirements for opening the valve.</p>

Illustration	Step	Description
	4	Place the relocking lever back in the holder.

6.4.7 Faults and anomalies

Faults and anomalies

The following table describes faults and anomalies which may occur during operation and describes action to rectify them

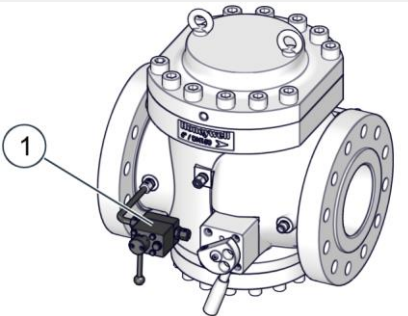
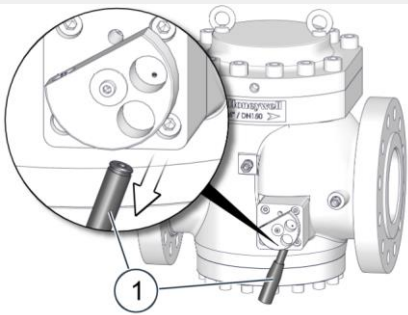
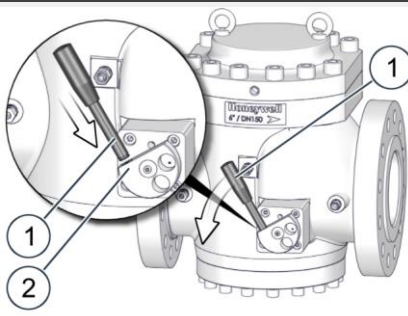
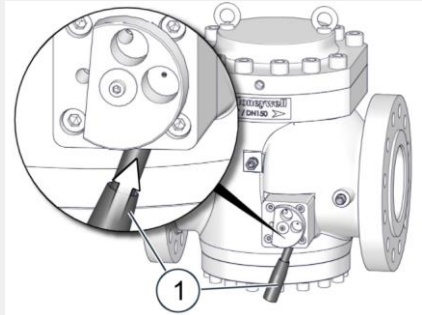
Fault	Possible cause	Rectification
No internal tightness in closed position	Main valve: main valve leaking.	Main valve: check the valve seat and gaskets for damage and dirt.
	By-pass valves: by-pass valves open or leaking	Check the by-pass valves.
Main valve cannot be opened	By-pass valve: no pressure equalization on main valve.	Equalize the pressure by opening the by-pass valve.
Main valve cannot be opened	Controller: differential between trip pressure and operating pressure or between upper and lower trip pressure too small	Correct the trip pressure setting (required relocking differential, see brochure or HON pocket book).
	Controller: measuring diaphragm in controller defective (after underpressure shut-off only).	Replace diaphragm.
	Sensing point: pressure too high.	Reduce pressure at sensing point to operating pressure.
	Sensing point: no pressure after underpressure shut-off only.	Increase pressure at sensing point to operating pressure.
Maximum allowable trip pressure deviation is exceeded	Control unit: release mechanism does not move easily due to dirt.	Carry out maintenance work on control unit.
	Controller: differential between trip pressure and operating pressure or between upper and lower trip pressure too small	Refer to the specified relocking differential when locking (see brochure or HON pocket book).
	Controller: measuring diaphragm stressed.	Check diaphragm.
	Control unit: release mechanism does not move easily due to dirt.	Carry out maintenance work on control unit.
	Control unit: wear on the release mechanism elements.	Replace damaged parts.
Irregularities in response	Test equipment: greatly varying pressure change rates during test process.	Apply the test pressure slowly and evenly.
	Controller: differential between trip pressure and operating pressure or between upper and lower trip pressure too small	Refer to the specified relocking differential when locking (see brochure or HON pocket book).
	Controller: measuring diaphragm stressed.	Check diaphragm.
	Control unit: release mechanism does not move easily due to dirt.	Carry out maintenance work on control unit.
Irregularities in response	Control unit: wear on the release mechanism elements.	Replace damaged parts.

Fault	Possible cause	Rectification
	Test equipment: greatly varying pressure change rates during test process.	Apply the test pressure slowly and evenly.
Gas escape through the vent lines	Controller: measuring diaphragm defective.	Replace diaphragm.

7 Maintenance

Contents

Topic	Page
Maintenance schedule	56
Preparing for the maintenance	57
Starting maintenance	58
Maintaining the actuator assembly	64
Completing the maintenance	98

7.1 Maintenance schedule

Meaning

Since the maintenance intervals are highly dependent on the operating conditions and the gas quality, it is impossible to provide set maintenance intervals.

It is recommended to use maintenance intervals conforming to the specifications in DVGW Code of Practice G 495. In addition, the need for maintenance must be determined and documented on the basis of operational requirements and experience.

Maintenance must be carried out in compliance with all federal and state laws and regulations, as well as with the local rules and regulations set forth by the relevant utilities and authorities and any other applicable regulations.

Maintenance schedule

Perform the following maintenance and repairs within the specified time intervals:

Task	See section	Interval			
		as needed	every 3 months	every year	every 5 years
Maintaining the actuator assembly	<i>Maintaining the actuator assembly (see page 73)</i>			●	
Maintaining the pilot	<i>Please refer to the component documentation for the pilot</i>	●			
Maintaining the monitoring device	<i>Please refer to the component documentation for the monitoring device</i>	●			

7.2 Preparing for the maintenance

Spare parts categories

Spare parts fall into the following categories:

Spare parts category	Definition
Maintenance part	Spare parts that always have to be replaced during maintenance.
Servicing parts	Spare parts that need to be checked during maintenance and that must be replaced if necessary due to their condition.
	Spare parts that qualified personnel employed by the company operating the device is allowed to replace in order to convert the device (e.g., when changing the pressure range).
	Spare parts that qualified personnel employed by the company operating the device is allowed to replace in the event of a fault or defect.

Protecting the pipe connections from being twisted

When conducting work involving the pipework, please always observe the following:

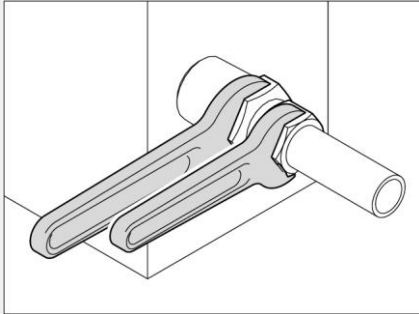
Figure	Description
	<p>Do not twist the pipe connections in the assemblies. Use a second spanner wrench for securing when loosening and tightening pipe joints.</p>

Preparation work for pilot maintenance

Proceed as follows:

Step	Description	Explanation
1	Have the maintenance and servicing parts ready	<p>Please refer to the drawings and lists in the <i>appendix</i> (see page 104) to find out which spare parts correspond your specific actuator assembly and have the corresponding maintenance parts and servicing parts ready to go before maintenance.</p> <ul style="list-style-type: none"> The spare parts that are always required for the actuator assembly's maintenance are grouped together in the spare parts kits in the <i>appendix</i> (see page 104). If components are damaged or are not working properly or at all due to heavy soiling that cannot be removed, contact the manufacturer in order to clarify the situation before putting the device back into operation. After clarifying the situation, you can order the relevant servicing parts from the manufacturer.
2	Have the required lubricants and threadlockers ready	<p>For specifications concerning the lubricants that must be used, please refer to the <i>Lubricants</i> (see page 126) section. If threadlockers are required, you will be able to find the corresponding information in the table before the relevant section in the maintenance manual.</p>
3	Have the required tools ready	<p>If special tools are required, you will be able to find the corresponding information at the beginning of the relevant section in the maintenance manual.</p>

Step	Description	Explanation
4	Removal and disassembly	<p>WARNING! Risk of serious injury posed by pressurized components moving in an uncontrolled manner when handled improperly. If not handled properly or in the event of a defect, gas can escape from pressurized components under high pressure and cause serious injuries and even death.</p> <p>Before you start working on these components:</p> <ul style="list-style-type: none"> ▪ Close all connections leading to the gas-carrying line. ▪ Establish a depressurized status. Residual amounts of energy must be depressurized as well. <p>If the actuator assembly is already installed in a pipe system, it can remain in the regulating line during maintenance. Operating the actuator assembly as a gas pressure regulator with a safety-shut off function is possible only in combination with an appropriate pilot and an appropriate monitoring device. If required, the pilot and the monitoring device need to be removed before starting the maintenance work. For instructions on how to remove the pilot, please refer to the user manual for the relevant gas pressure regulator. Keep in mind that it is always necessary to depressurize the actuator assembly (including the pilot and monitoring device) and purge all gas-conveying lines with nitrogen before removal.</p>

Sample maintenance instructions

The maintenance instructions below are provided as examples for the various actuator assembly designs and versions. In other words, it does not explicitly describe every single version and design. Use the bills of materials to make sure that you replace all the maintenance parts relevant to your specific device model during maintenance.

If you have trouble understanding the information in this documentation, contact the manufacturer without fail before starting any work on the device.

7.3 Starting maintenance

Pressurized parts

⚠ WARNING

Risk of serious injury posed by pressurized components moving in an uncontrolled manner when handled improperly.

If not handled properly or in the event of a defect, gas can escape from pressurized components under high pressure and cause serious injuries and even death. Before you start working on these components:

- ⇒ Close all connections leading to the gas-carrying line.
- ⇒ Establish a depressurized status. Residual amounts of energy must be depressurized as well.

Overview

The test setup is as follows (schematic diagram, using the two-stage HON 630 pilot with a diaphragm assembly and an HON 670 / 671 monitoring device as a reference):

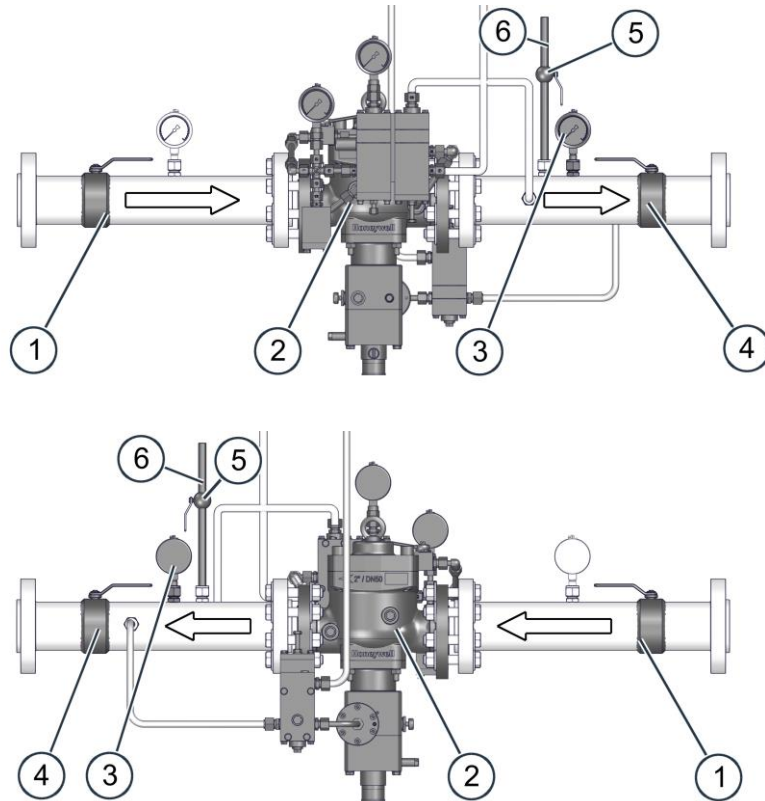

The numbers have the following meaning:

No.	Meaning
1	Inlet stop valve armature
2	Gas pressure regulator
3	Pressure gauge
4	Outlet stop valve armature
5	Valve for blowdown line
6	Blowdown line

Establishing the depressurized status

Proceed as follows:

Step	Description
1	Close the outlet stop valve armature (4).
2	Close the inlet stop valve armature (1).
3	Depressurize the pilot: Turn the set screw on the pilot's control stage – and the set screw on the pilot's load limiting stage as well if applicable – clockwise until the pressure in the pilot is equalized.
4	Open the ball valve (5) in the blowdown line (6) to discharge the pressure between the inlet and the outlet valves.
5	Depressurize the monitoring device: Close the outlet and inlet shut-off devices and open the ball valve in the blowdown line. This will cause the gas to blow out completely and depressurize the monitoring device.

Purging the lines with nitrogen

All the gas pressure regulator's lines must be purged with nitrogen before the device is removed.

Protecting the pipe connections from being twisted

When conducting work involving the pipework, please always observe the following:

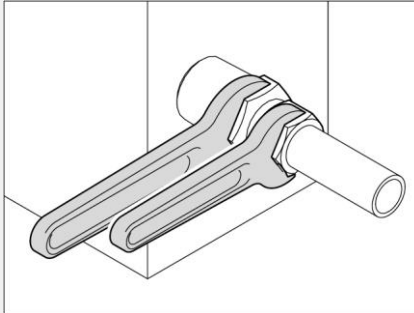
Figure	Description
	<p>Do not twist the pipe connections in the assemblies. Use a second spanner wrench for securing when loosening and tightening pipe joints.</p>

Removing components

If ...	then ...
<p>You want to perform maintenance on the pilot only</p>	<ul style="list-style-type: none"> ▪ The measuring line and the vent line on the pilot need to be uninstalled. ▪ The inlet pressure line, motorization line, and outlet pressure line on the pilot need to be uninstalled. ▪ The actuator assembly, including the pipes, can remain in the gas regulating line.
<p>You want to perform maintenance on the monitoring device only</p>	<ul style="list-style-type: none"> ▪ The measuring line and the vent line on the monitoring device need to be uninstalled. ▪ The pressure unit* can remain on the SAV. *) HON 670 / 671 model
<p>You want to perform maintenance on the pressure unit* only. *) HON 670 / 671 model</p>	<ul style="list-style-type: none"> ▪ The connection line between the monitoring device and the pressure unit* must be removed. ▪ The monitoring device can remain in the gas regulating line.
<p>You want to perform maintenance on the monitoring device and the pressure unit*. *) HON 670 / 671 model</p>	<ul style="list-style-type: none"> ▪ The measuring line and the vent line on the monitoring device need to be uninstalled. ▪ The connection line between the monitoring device and the pressure unit must be removed.
<p>You want to perform maintenance on the actuator assembly only</p>	<ul style="list-style-type: none"> ▪ The motorization line between the pilot and the actuator assembly needs to be uninstalled. ▪ The actuator assembly can remain in the gas regulating line. ▪ The pilot, including the remaining pipes (with the exception of the motorization line), can remain in the gas regulating line.
<p>You want to maintain the actuator assembly, pilot, and monitoring device with the pressure unit* *) HON 670 / 671 model</p>	<ul style="list-style-type: none"> ▪ The measuring line and the vent line on the pilot need to be uninstalled. ▪ The motorization line between the pilot and the actuator assembly needs to be uninstalled. ▪ The pilot needs to be removed from the actuator assembly. ▪ The measuring line and the vent line on the monitoring device need to be uninstalled. ▪ The connection line between the monitoring device and the pressure unit must be removed. ▪ The pressure unit needs to be removed from the actuator assembly. ▪ The actuator assembly, including the remaining pipes (with the exception of the motorization line), can remain in the gas regulating line.

To remove the pilot, follow the steps below:

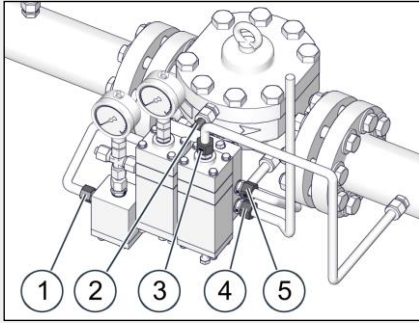
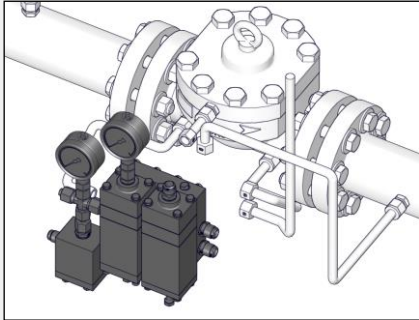
Figure	Step	Description
	1	Disconnect all the pilot and monitoring device pipes: <ul style="list-style-type: none"> ▪ Inlet pressure line (1) ▪ Motorization line (2) ▪ Measuring line (3) ▪ Vent line (4) ▪ Outlet pressure line (5)
	2	Remove the pilot.

To remove the monitoring device, follow the steps below (HON 670 / 671 model):

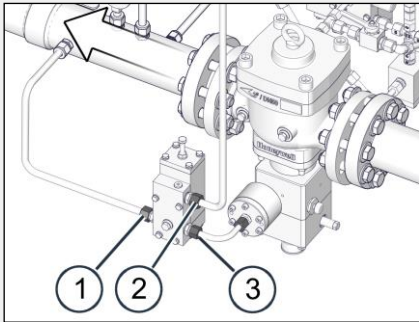
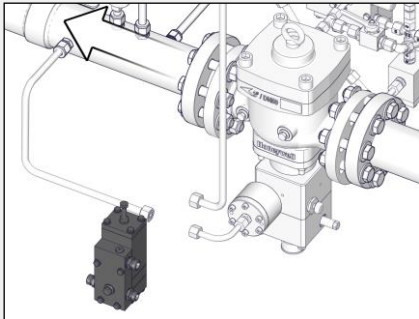
Figure	Step	Description
	1	Disconnect all the monitoring device pipes: <ul style="list-style-type: none"> ▪ Outlet pressure line (1) ▪ Vent line (2) ▪ Monitoring device / pressure unit connection line (3)
	2	Remove the monitoring device.

To remove the monitoring device, follow the steps below (HON 672 model):

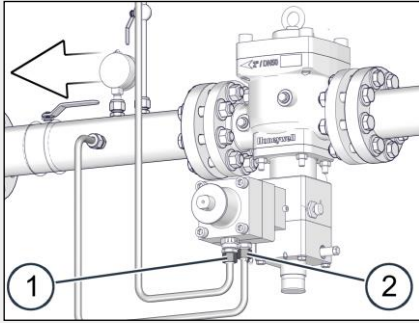
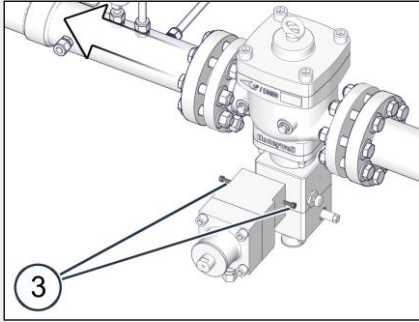
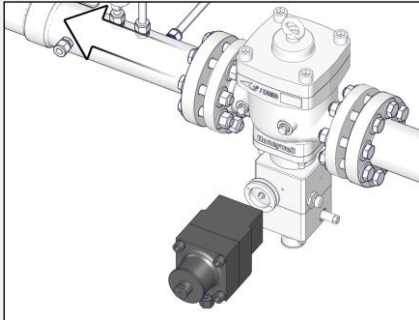
Figure	Step	Description
	1	Disconnect all the monitoring device pipes: <ul style="list-style-type: none"> ▪ Vent line (1) ▪ Outlet pressure line (2)
	2	Unscrew the screws (3).
	3	Remove the monitoring device.

To remove the monitoring device, follow the steps below (HON 673 model):

Figure	Step	Description
	1	Disconnect all the monitoring device pipes: <ul style="list-style-type: none"> ▪ Vent line (1) ▪ Outlet pressure line (2)

Figure	Step	Description
	2	Hold the monitoring device and unscrew the two screws (3) that are inserted in an inclined direction into the monitoring device, one on the right side and the other on the left side.
	3	Remove the monitoring device.

To remove the pressure unit, follow the steps below (HON 670 / 671 model):

Figure	Step	Description
	1	Disconnect all the pressure unit pipes: <ul style="list-style-type: none"> ▪ Monitoring device / pressure unit connection line (1) Unscrew the set screw (2) three turns.
	2	Turn the pressure unit and remove it.

7.4 Maintaining the actuator assembly

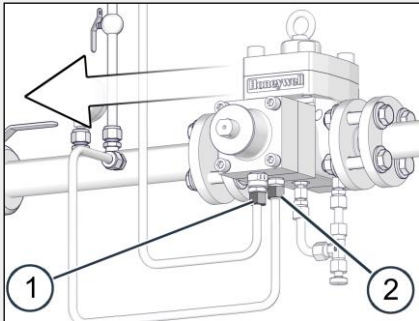
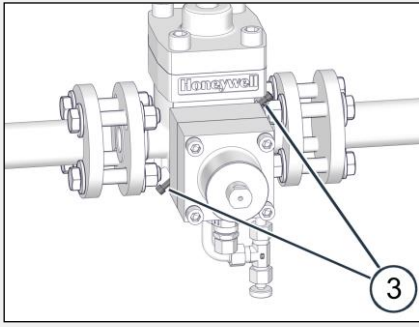
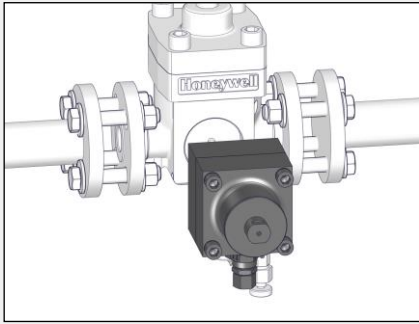
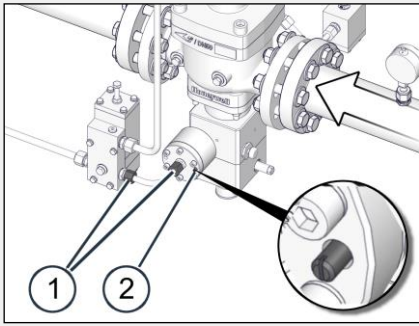
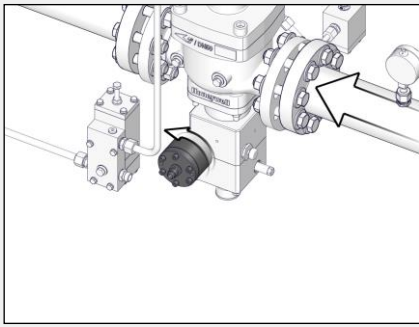
Contents

Topic	Page
Removing the triggering unit - 1" size	64
Removing the triggering unit - 2", 3", 4" size	66
Removing the triggering unit - 6" size	68
Maintaining the actuator assembly - all sizes	73
Maintaining the triggering unit - 1" size	75
Maintaining the triggering unit - 2", 3", 4" size	79
Maintaining the triggering unit - 6" size	85
Maintaining the HON 910 push-button valve - 6" size	86
Installing the triggering unit - 1" size	88
Installing the triggering unit - 2", 3", 4" size	90
Installing the triggering unit - 6" size	91

7.4.1 Removing the triggering unit - 1" size

Moving heavy weights

⚠ WARNING

Risk of injury due to improper lifting

When lifting and handling device components, the weight of the components and assemblies can result in injury, especially in the torso area.

- ⇒ Make sure to always have enough people lifting heavy device components (guideline using metric units: 15 - max. 55 kg / guideline using imperial units: 30 - max. 120 lbs, depending on age and gender). Comply with all the occupational health and safety regulations and instructions that apply at the installation location!
- ⇒ Use suitable hoisting equipment and slings in order to handle heavy device components. Make sure to take into account the device components' center of gravity and to attach the slings only to the secure device component locations intended for this purpose.
- ⇒ Wear the required personal protective equipment.

Falling components

⚠ CAUTION

Crush and impact hazard posed by components falling or toppling over accidentally.

When working with heavy components that have been removed or are yet to be installed, injury may result if the components start moving in an uncontrolled manner, e.g., fall down from the working surface or topple over.

- ⇒ Place removed components exclusively on level, horizontal working surfaces with enough load-bearing capacity.
- ⇒ If necessary, secure removed components so that they will not fall or topple over.
- ⇒ Wear the required personal protective equipment.
- ⇒ Exercise caution when performing the relevant tasks.

Requirements

Make sure that the following requirements are met:

- The safety shut-off valve must have been triggered and must accordingly be closed.
- The system must be depressurized and all gas-conveying lines must have been purged with nitrogen.

WARNING! Risk of serious injury posed by pressurized components moving in an uncontrolled manner when handled improperly.

If not handled properly or in the event of a defect, gas can escape from pressurized components under high pressure and cause serious injuries and even death.

Before you start working on these components:

- Close all connections leading to the gas-carrying line.
- Establish a depressurized status. Residual amounts of energy must be depressurized as well.

Removing the triggering unit from the actuator assembly

Proceed as follows:

Figure	Step	Description
	1	There are two screws (1, 2) that are inserted in an inclined direction into the assembly, one on the right side and the other on the left side. Unscrew both of them.
	2	Remove the switching unit (1) from the actuator assembly.
	3	<ul style="list-style-type: none"> ▪ Unscrew the screws (1) on the shut-off unit. ▪ Take the screws (1) and washers (2) and set them aside.

Figure	Step	Description
	4	Remove the shut-off unit (1) from the actuator assembly in a straight horizontal line.

Next task

Proceed as follows:

- *Maintaining the actuator assembly* (see page 73)
- *Maintaining the triggering unit - 1" size* (see page 75)

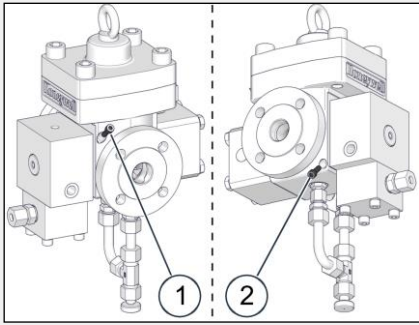
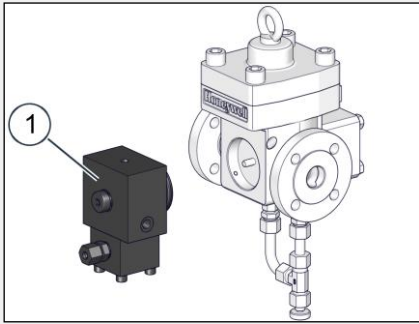
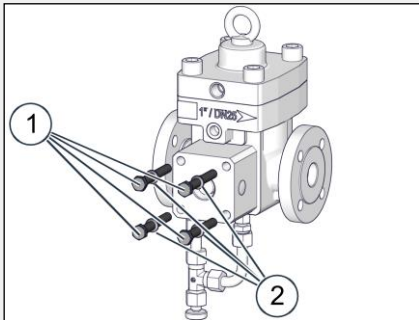
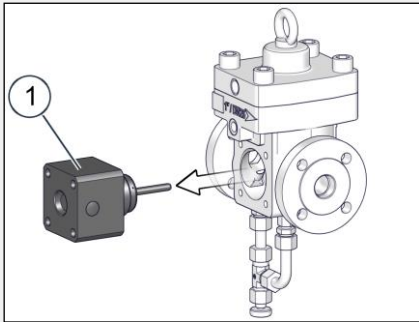
7.4.2 Removing the triggering unit - 2", 3", 4" size

Moving heavy weights
⚠ WARNING
Risk of injury due to improper lifting

When lifting and handling device components, the weight of the components and assemblies can result in injury, especially in the torso area.

- ⇒ Make sure to always have enough people lifting heavy device components (guideline using metric units: 15 - max. 55 kg / guideline using imperial units: 30 - max. 120 lbs, depending on age and gender). Comply with all the occupational health and safety regulations and instructions that apply at the installation location!
- ⇒ Use suitable hoisting equipment and slings in order to handle heavy device components. Make sure to take into account the device components' center of gravity and to attach the slings only to the secure device component locations intended for this purpose.
- ⇒ Wear the required personal protective equipment.

Falling components
⚠ CAUTION
Crush and impact hazard posed by components falling or toppling over accidentally.

When working with heavy components that have been removed or are yet to be installed, injury may result if the components start moving in an uncontrolled manner, e.g., fall down from the working surface or topple over.

- ⇒ Place removed components exclusively on level, horizontal working surfaces with enough load-bearing capacity.
- ⇒ If necessary, secure removed components so that they will not fall or topple over.
- ⇒ Wear the required personal protective equipment.
- ⇒ Exercise caution when performing the relevant tasks.

Requirements

Make sure that the following requirements are met:

- The safety shut-off valve must have been triggered and must accordingly be closed.
- The system must be depressurized and all gas-conveying lines must have been purged with nitrogen.

WARNING! Risk of serious injury posed by pressurized components moving in an uncontrolled manner when handled improperly.

If not handled properly or in the event of a defect, gas can escape from pressurized components under high pressure and cause serious injuries and even death.

Before you start working on these components:

- Close all connections leading to the gas-carrying line.
- Establish a depressurized status. Residual amounts of energy must be depressurized as well.

Removing the triggering unit from the actuator assembly

Proceed as follows:

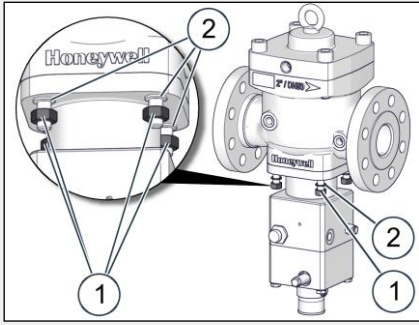
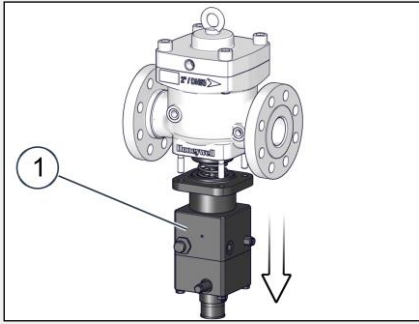
Figure	Step	Description
	1	Unscrew the nuts (1) on the connection flange. Caution! The triggering unit is spring-loaded. Risk of injury due to the triggering unit being hurled quickly in one direction when the nuts are unscrewed. Secure the triggering unit in place when unscrewing the nuts. Set the nuts (1) and washers (2) aside.
	2	Remove the triggering unit (1) from the actuator assembly.

Next task

Proceed as follows:

- *Maintaining the actuator assembly* (see page 73)
- *Maintaining the triggering unit - 2", 3", 4" size* (see page 79)

7.4.3 Removing the triggering unit - 6" size

Moving heavy weights

⚠️ WARNING

Risk of injury due to improper lifting

When lifting and handling device components, the weight of the components and assemblies can result in injury, especially in the torso area.

- ⇒ Make sure to always have enough people lifting heavy device components (guideline using metric units: 15 - max. 55 kg / guideline using imperial units: 30 - max. 120 lbs, depending on age and gender). Comply with all the occupational health and safety regulations and instructions that apply at the installation location!
- ⇒ Use suitable hoisting equipment and slings in order to handle heavy device components. Make sure to take into account the device components' center of gravity and to attach the slings only to the secure device component locations intended for this purpose.
- ⇒ Wear the required personal protective equipment.

Falling components

⚠️ CAUTION

Crush and impact hazard posed by components falling or toppling over accidentally.

When working with heavy components that have been removed or are yet to be installed, injury may result if the components start moving in an uncontrolled manner, e.g., fall down from the working surface or topple over.

- ⇒ Place removed components exclusively on level, horizontal working surfaces with enough load-bearing capacity.
- ⇒ If necessary, secure removed components so that they will not fall or topple over.
- ⇒ Wear the required personal protective equipment.
- ⇒ Exercise caution when performing the relevant tasks.

Requirements

Make sure that the following requirements are met:

- The safety shut-off valve must have been triggered and must accordingly be closed.
- The system must be depressurized and all gas-conveying lines must have been purged with nitrogen.

WARNING! Risk of serious injury posed by pressurized components moving in an uncontrolled manner when handled improperly.

If not handled properly or in the event of a defect, gas can escape from pressurized components under high pressure and cause serious injuries and even death.

Before you start working on these components:

- Close all connections leading to the gas-carrying line.
- Establish a depressurized status. Residual amounts of energy must be depressurized as well.

Removing the triggering unit from the actuator assembly

Proceed as follows:

Figure	Step	Description
	<p>1</p>	<p>Remove the pressure compensating valve (1).</p>
	<p>2</p>	<ul style="list-style-type: none"> ▪ Unscrew the screws (2) on the switching unit housing's cover and remove the cover (3). ▪ Take the screws (2), washers (1), and cover (3) and set them aside.
	<p>3</p>	<p>Unscrew the manual trigger (2) and the spring-loaded pressure piece (1) from the switching unit housing.</p>
	<p>4</p>	<p>Pull out the star wheel (1) from the plain bearing on the guiding cylinder.</p>
	<p>5</p>	<p>Inside the switching unit housing, unscrew the screw (1) on the valve rod and remove the washer (2).</p>

Figure	Step	Description
	6	<ul style="list-style-type: none"> ▪ Unscrew the screws (1) used to secure the switching unit housing. ▪ Take the screws (1) and washers (2) and set them aside.
	7	<p>Remove the remaining switching unit assembly (1) from the valve rod and from the actuator assembly by pulling it out in a straight horizontal line.</p>
	8	<ul style="list-style-type: none"> ▪ Unscrew the screws (1) on the actuator assembly's bottom cover. ▪ Take the screws (1) and washers (2) and set them aside.
	9	<p>Remove the bottom cover (1) from the actuator assembly.</p>
	10	<p>Unscrew the screws (1) for the flap valve inside the actuator assembly body.</p>

Figure	Step Description
	<p>11 Push the valve rod (2) with the opening element (1) as far as possible in the direction shown.</p>
	<p>12 On the switching unit's side, remove the retaining ring (1) on the valve rod (2).</p>
	<p>13</p> <ul style="list-style-type: none"> ▪ On the opening element (3), unscrew the screw (1) on the valve rod and remove the washer (2). ▪ Set the opening element aside.
	<p>14 Use the screw (2) to secure the washer (1) back on the valve rod (3).</p>
	<p>15</p> <ul style="list-style-type: none"> ▪ Unscrew the four screws (1) on the spring housing. Before unscrewing the last two screws, use the re-engaging lever (3) to hold the spring housing (3) in position. ▪ CAUTION! Springs that are under tension can cause the spring housing to jump suddenly, resulting in hand injuries. ▪ Take the screws (1) and washers (2) and set them aside.

Figure	Step	Description
	<p>16</p>	<ul style="list-style-type: none"> ▪ Hold the spring housing (2) with the re-engaging lever (1). ▪ Pull the spring housing (2) away from the milled-out area inside the actuator assembly body while holding it so that it will not rotate by itself. ▪ Now carefully turn the spring housing (2) with the re-engaging lever (1) in order to relieve the tension from the closing springs.
	<p>17</p>	<ul style="list-style-type: none"> ▪ On the spring housing (3), unscrew the screw (1) on the valve rod and remove the washer (2). ▪ Then pull the spring housing (3) from the valve rod. ▪ Remove the closing springs. Check the condition of the closing springs (4) after cleaning. If they are damaged, replace the closing springs with new ones.
	<p>18</p>	<p>On the switching unit side, pull the sleeve (2) with the valve rod (1) out from the actuator assembly in a straight horizontal line.</p> <p>CAUTION! The flap valve inside the actuator assembly will come loose, and may result in injuries if it falls. Hold the flap valve in place and secure its position.</p>
	<p>19</p>	<ul style="list-style-type: none"> ▪ Remove the valve rod (1) with the sleeve (2). ▪ Remove the key (3). ▪ Remove the flap valve (4) from the actuator assembly.
	<p>20</p>	<p>Remove the remaining sleeve (2) on the spring housing side from the inside of the actuator assembly.</p>

Next task

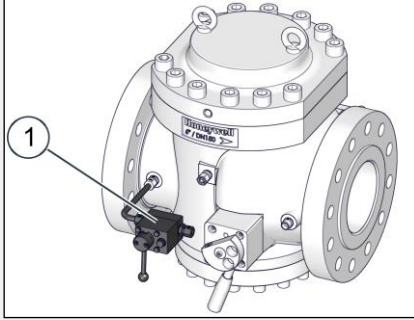
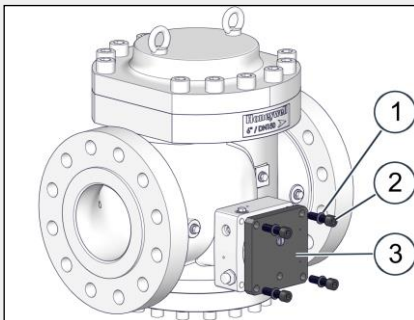
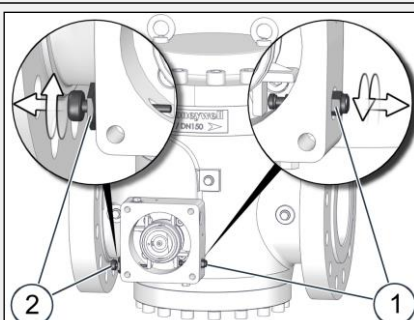
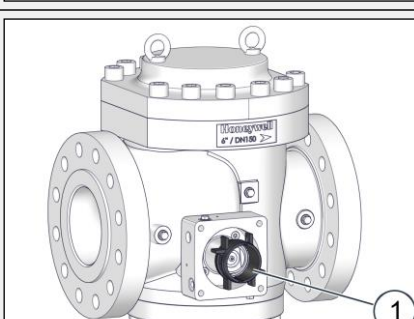
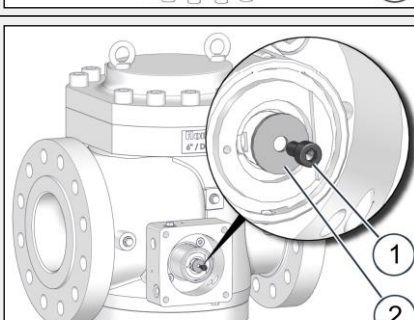
Proceed as follows:

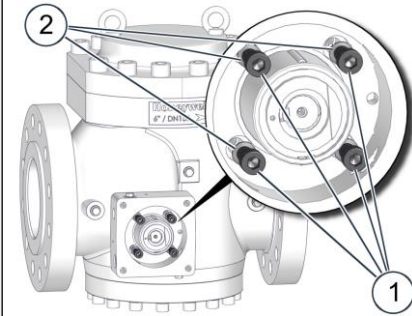
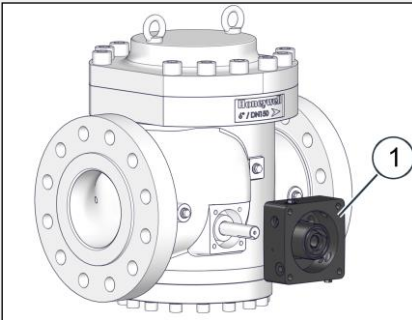
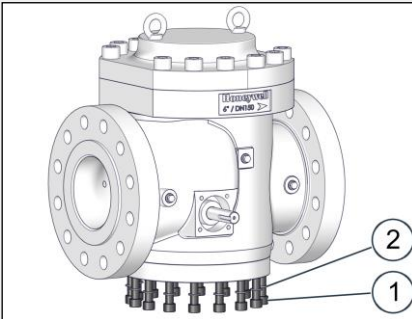
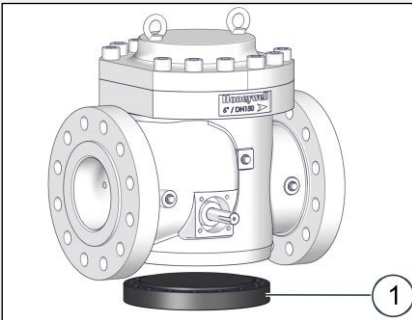
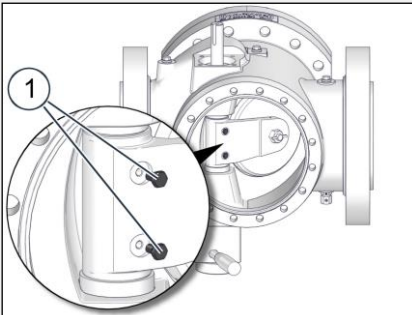
- *Maintaining the actuator assembly* (see page 73)
- *Maintaining the triggering unit - 6" size* (see page 85)

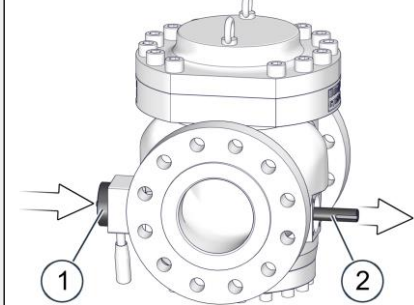
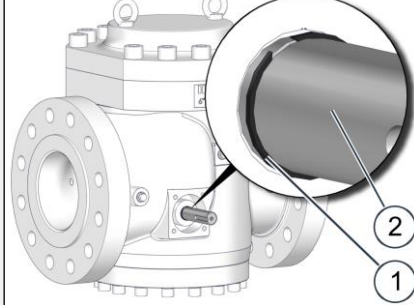
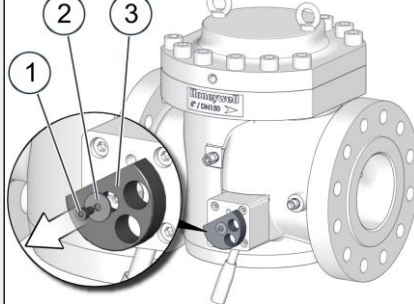
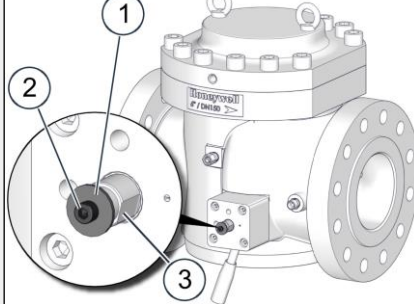
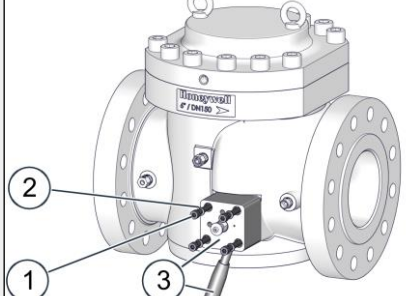
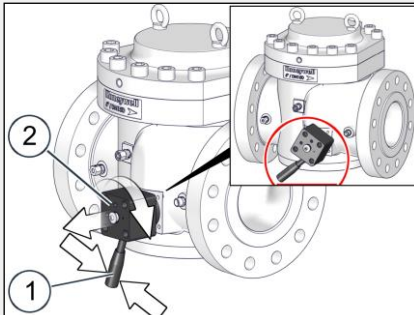
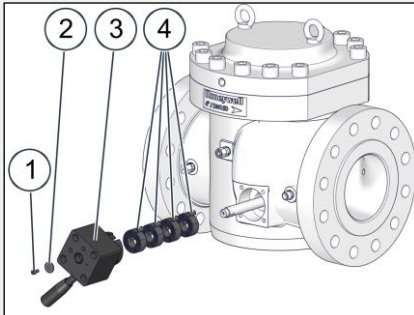
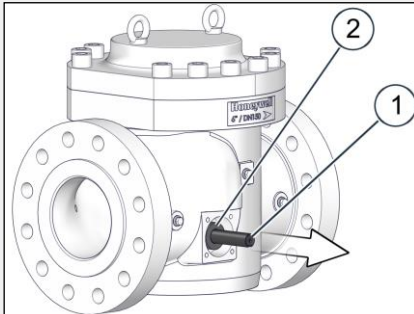
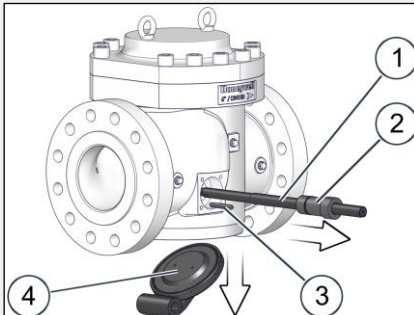
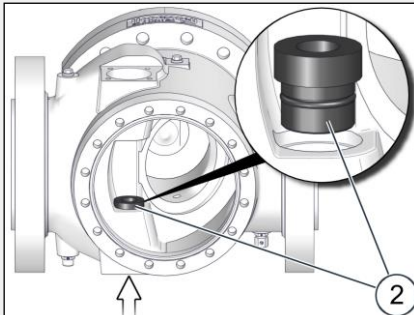
7.4.4 Maintaining the actuator assembly - all sizes

Falling components

Crush and impact hazard posed by components falling or toppling over accidentally.

When working with heavy components that have been removed or are yet to be installed, injury may result if the components start moving in an uncontrolled manner, e.g., fall down from the working surface or topple over.

- ⇒ Place removed components exclusively on level, horizontal working surfaces with enough load-bearing capacity.
- ⇒ If necessary, secure removed components so that they will not fall or topple over.
- ⇒ Wear the required personal protective equipment.
- ⇒ Exercise caution when performing the relevant tasks.

Cleaning

Observe the following cleaning instructions:

- Before assembly, all parts must be cleaned in order to remove any foreign particles (swarf) and soiling.
- If screws, bolts, or washers are replaced with identical new parts, any oil on these new parts must first be removed.

Tightening torques

Tightening torques of the bolts securing the regulator **top cover** are as follows:

Nominal size	Pressure rating	Screw specifications	Tightening torque
1" (DN 25)	Class 150/300/600 PN 16/25/40	M16	203 Nm (150 ft lbs)
2" (DN 50)	Class 150/300/600 PN 16/25/40	M16	203 Nm (150 ft lbs)
3" (DN 80)	Class 150 PN 16	M16	203 Nm (150 ft lbs)
3" (DN 80)	Class 300/600 PN 25/40	M20	353 Nm (260 ft lbs)
4" (DN 100)	Class 150 PN 16	M16	203 Nm (150 ft lbs)
4" (DN 100)	Class 300/600 PN 25/40	M20	353 Nm (260 ft lbs)
6" (DN 150)	Class 150 PN 16	M16	203 Nm (150 ft lbs)
6" (DN 150)	Class 300 PN 25/40	M20	353 Nm (260 ft lbs)
6" (DN 150)	Class 600	M24	705 Nm (520 ft lbs)

In addition, observe the tightening torque and threadlocker specifications below when following the instructions in this section:

Part	Tightening torque	Threadlocker	Step
Diaphragm unit screw	27 Nm (20 ft lbs)	LOCTITE 221	7
Flow restrictor screws	6 Nm (4.5 ft lbs)	LOCTITE 221	8

Maintaining the actuator assembly

Proceed as follows:

Figure	Step	Description
	1	Disassemble the lid. CAUTION! The lid is spring-loaded. Risk of injury due to bouncing up when the screws are unscrewed. Push the lid down when unscrewing the screws.
	2	Remove the closing spring (1) and the diaphragm unit (2).
	3	<ul style="list-style-type: none"> Remove the flow restrictor. If the flow restrictor is damaged: Replace the flow restrictor with a new one.
	4	<ul style="list-style-type: none"> Replace the O-ring (1) with a new, greased O-ring. Remove the noise reduction element (2) and the supporting shim (3) if these optional parts are installed in your device. Check the noise reduction element and the support disc for damage and replace them if necessary.

Figure	Step	Description
	5	If the diaphragm is damaged: Dismantle the diaphragm unit. Replace the diaphragm with a new diaphragm.
	6	Lightly grease the inside and outside edge of the new diaphragm.
	7	Re-assemble the diaphragm unit. Observe the additional tightening torque and threadlocker specifications provided in the table before this section.
	8	Re-assemble the regulator unit. <ul style="list-style-type: none"> ▪ For the flow restrictor screws, observe the additional tightening torque and threadlocker specifications provided in the table before this section. ▪ Push the lid down when screwing down the screws until they are completely secured. Tighten the screws in a criss-cross sequence step by step. Observe the tightening torque information provided in the table before this section.

7.4.5 Maintaining the triggering unit - 1" size

Falling components

CAUTION

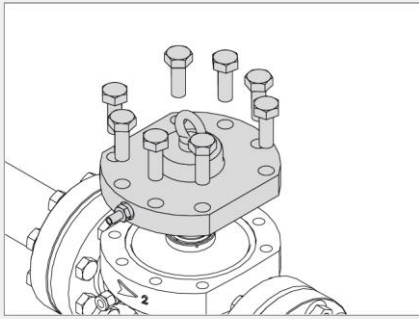
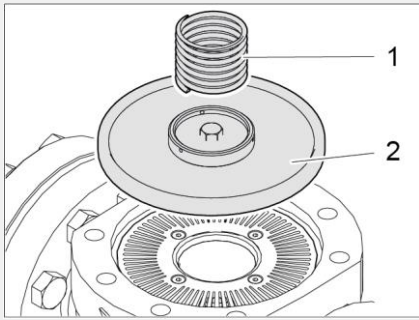
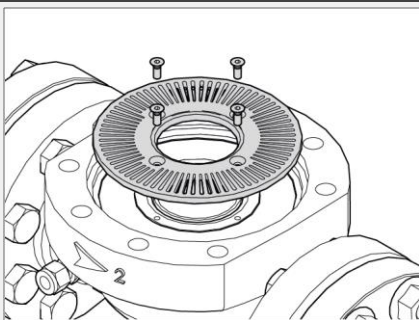
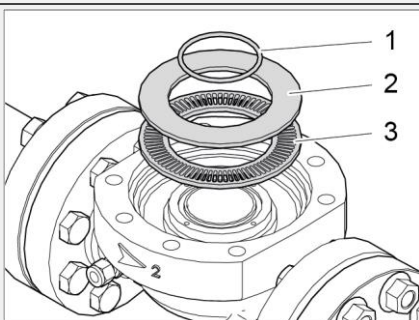
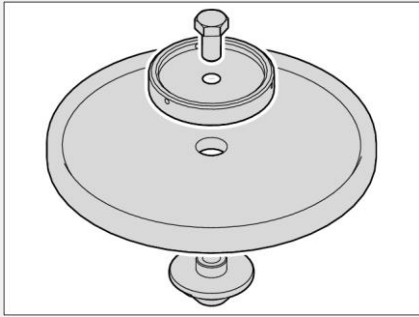
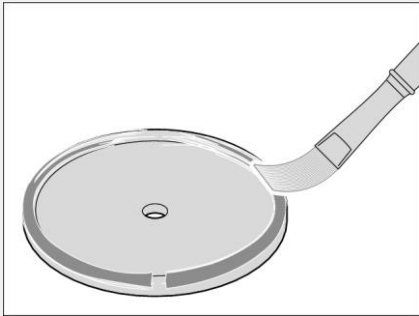
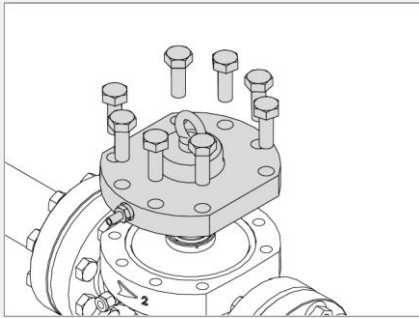
Crush and impact hazard posed by components falling or toppling over accidentally.

When working with heavy components that have been removed or are yet to be installed, injury may result if the components start moving in an uncontrolled manner, e.g., fall down from the working surface or topple over.

- ⇒ Place removed components exclusively on level, horizontal working surfaces with enough load-bearing capacity.
- ⇒ If necessary, secure removed components so that they will not fall or topple over.
- ⇒ Wear the required personal protective equipment.
- ⇒ Exercise caution when performing the relevant tasks.

Cleaning

Observe the following cleaning instructions:

- Before assembly, all parts must be cleaned in order to remove any foreign particles (swarf) and soiling.
- If screws, bolts, or washers are replaced with identical new parts, any oil on these new parts must first be removed.

Tightening torques

Observe the tightening torques below when following the instructions in this section:

Part	Tightening torque	Step
Screws	20 Nm (15 ft lbs)	14

Maintaining the triggering unit

Proceed as follows:

Figure	Step	Description
	1	Take the shut-off unit: <ul style="list-style-type: none"> ▪ Remove the cap (1). ▪ Remove the retaining ring (2).
	2	Remove the valve rod unit (1) and the guide sleeve (2), moving each of them away from the shut-off unit housing in the right direction.
	3	Take the shut-off unit housing: <ul style="list-style-type: none"> ▪ Replace the O-ring (1) with a new, greased O-ring. ▪ Replace the O-ring (2) with a new, greased O-ring.
	4	Take the valve rod unit: <ul style="list-style-type: none"> ▪ Check the condition of the valve rod unit (2) after cleaning. If the valve rod unit is damaged, replace it with a new one. ▪ Lightly grease the valve rod, making sure to observe the lubricant table in the appendix. ▪ Remove the used O-ring (1) from the valve disc.

Figure	Step	Description
	<p>5</p>	<ul style="list-style-type: none"> ▪ Insert a new, greased O-ring (1) into the valve disc's groove. ▪ Press on the O-ring at several points evenly distributed along the circumference in order to push it into the groove. ▪ Then press everywhere on the O-ring in order to fully push it in.
	<p>6</p>	<p>Reassemble the shut-off unit:</p> <ul style="list-style-type: none"> ▪ Put the spring (3) back on the valve rod unit (2). ▪ Thread the valve rod unit (2) through the hole in the shut-off unit housing (1). ▪ Slide the guide sleeve (4) inside the housing onto the valve rod. ▪ Use the retaining ring (5) to secure the guide sleeve (4) on the valve rod. ▪ Put the cap (6) back in place.
	<p>7</p>	<p>Take the switching unit:</p> <ul style="list-style-type: none"> ▪ Unscrew the screws (1) on the switching unit housing's cover. ▪ Take the screws (1) and washers (2) and set them aside.
	<p>8</p>	<p>Remove the switching unit housing's cover (1) directly downward and away from the switching unit housing.</p>
	<p>9</p>	<p>Remove the switching disc unit and the compression spring from the switching unit housing's cover.</p>

Figure	Step	Description
	<p>10</p>	<ul style="list-style-type: none"> ▪ Replace the sealing ring (2) inside the switching unit housing's cover with a new, greased sealing ring. ▪ Lubricate the thread surfaces before screwing the fitting (1) back in.
	<p>11</p>	<p>Replace the O-ring (1) on the switching disc unit (2) with a new, greased O-ring.</p>
	<p>12</p>	<p>Place the compression spring and the switching disc unit back in the switching unit housing's cover.</p>
	<p>13</p>	<p>Take the switching unit housing:</p> <ul style="list-style-type: none"> ▪ Replace the O-ring (1) with a new, greased O-ring. ▪ Replace the O-ring (2) with a new, greased O-ring.
	<p>14</p>	<p>Use the screws (3) and washers (4) to mount the reassembled switching unit housing cover (1) back on the switching unit housing (2). Observe the tightening torque information provided in the table before this section.</p>

Next task

Proceed as follows:

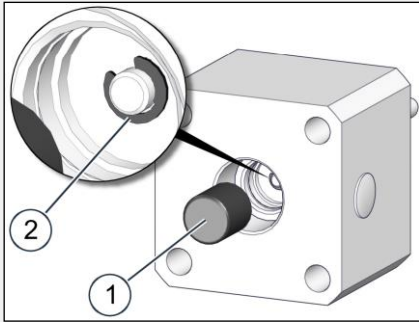
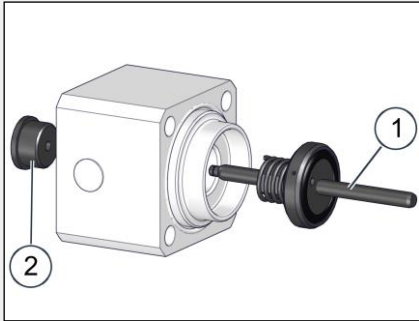
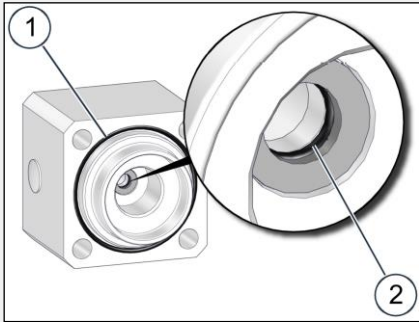
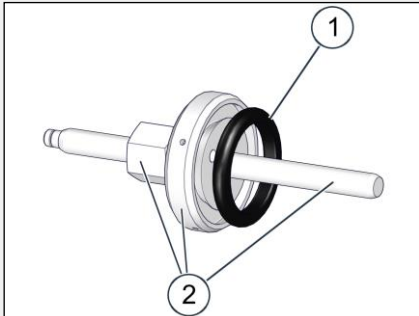
- *Installing the triggering unit - 1" size (see page 88)*

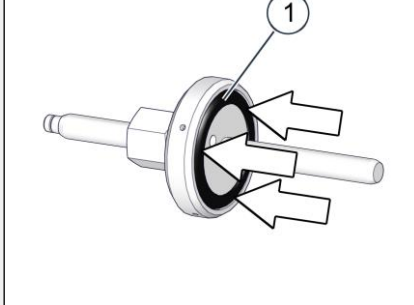
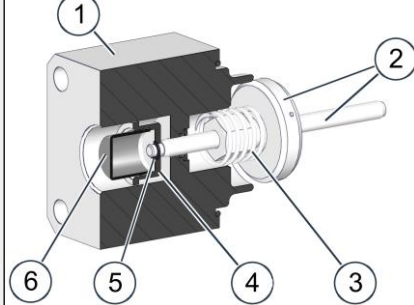
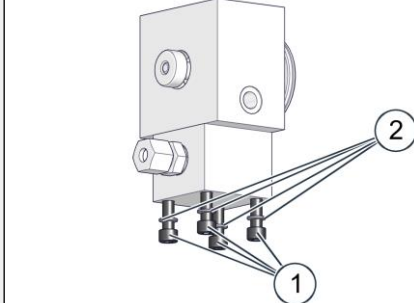
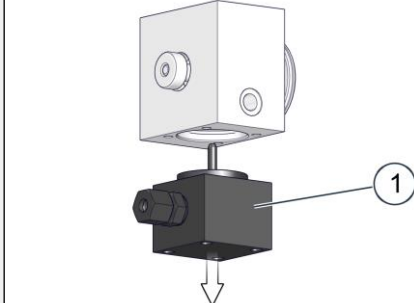
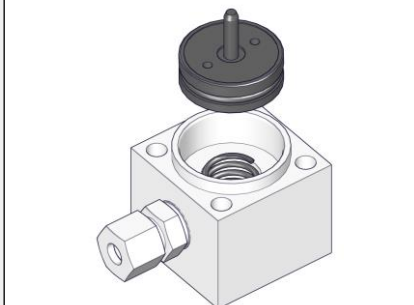
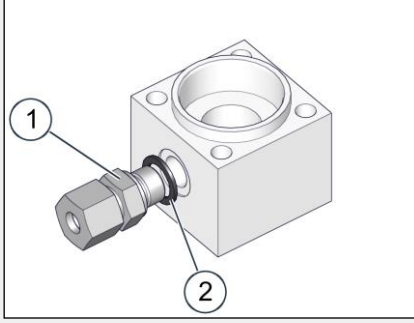
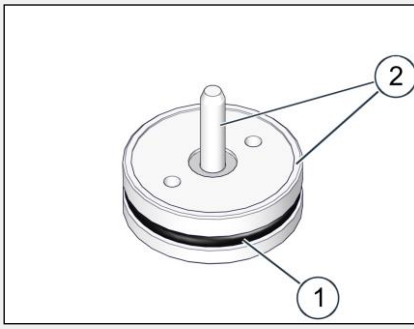
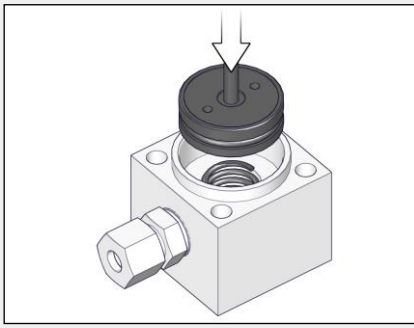
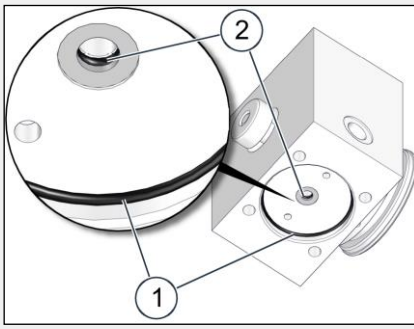
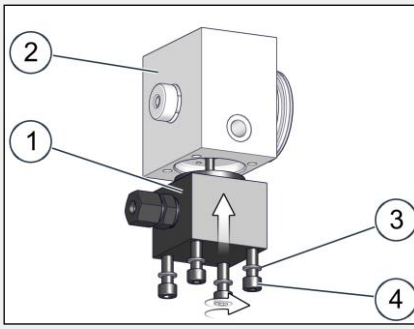
7.4.6 Maintaining the triggering unit - 2", 3", 4" size

Falling components



Crush and impact hazard posed by components falling or toppling over accidentally.

When working with heavy components that have been removed or are yet to be installed, injury may result if the components start moving in an uncontrolled manner, e.g., fall down from the working surface or topple over.

- ⇒ Place removed components exclusively on level, horizontal working surfaces with enough load-bearing capacity.
- ⇒ If necessary, secure removed components so that they will not fall or topple over.
- ⇒ Wear the required personal protective equipment.
- ⇒ Exercise caution when performing the relevant tasks.

Cleaning

Observe the following cleaning instructions:

- Before assembly, all parts must be cleaned in order to remove any foreign particles (swarf) and soiling.
- If screws, bolts, or washers are replaced with identical new parts, any oil on these new parts must first be removed.

Special tools

Prepare the following special tools in addition to the standard tools:

Figure	Description
	Assembly aid (10026350)

Tightening torques

Observe the tightening torque and threadlocker specifications below when following the instructions in this section:

Part	Tightening torque	Threadlocker	Step
Cylinder screws	16 Nm (12 ft lbs)	-	14
Pinion shaft / valve shank	16 Nm (12 ft lbs)	LOCTITE 241	19
Screws	16 Nm (12 ft lbs)	-	20

Maintaining the triggering unit

Proceed as follows:

Figure	Step	Description
	1	<ul style="list-style-type: none"> ▪ Unscrew the screws (1) on the switching unit housing's cover. ▪ Take the screws (1) and washers (2) and set them aside.

Figure	Step	Description
	2	Remove the switching unit housing's cover (1).
	3	<ul style="list-style-type: none"> ▪ Remove the valve shank unit (3). To do this, use an Allen key (1) to unscrew the pinion shaft (2) from the valve shank unit. ▪ Remove the valve shank unit and the pinion shaft, moving each of them away from the switching unit housing in the right direction.
	4	Remove the spring (1) and the circlip (2) from the valve shank unit.
	5	Remove the valve plate (1) from the valve shank.
	6	Unscrew the hex nut (1) and remove it from the valve shank (2).

Figure	Step	Description
	7	<p>Slowly remove the vulcanized valve plate (1) from the valve shank. Two half-disks will fall out.</p>
	8	<p>Replace the O-ring (1) with a new, greased O-ring. Check the valve shank for damage. Replace the valve shank if necessary. Lightly grease the valve shank, making sure to observe the lubricant table in the appendix</p>
	9	<p>Hold the two half-disks in place and slide the vulcanized valve plate (1) back onto the valve shank.</p>
	10	<p>Screw the hex nut (1) back onto the valve shank, onto the vulcanized valve plate.</p>
	11	<p>Reassemble the valve shank unit:</p> <ul style="list-style-type: none"> ▪ Slide the valve plate (2) onto the valve shank unit (1). ▪ Use a new circlip (3) to secure the valve plate. ▪ Put the spring (4) in place.

Figure	Step	Description
	<p>12</p>	<ul style="list-style-type: none"> ▪ Take the switching unit housing. ▪ Replace the O-ring (1) with a new, greased O-ring. Use the assembly aid intended for this purpose.
	<p>13</p>	<p>Unscrew the manual trigger (1) and the spring-loaded pressure piece (2) from the switching unit housing.</p>
	<p>14</p>	<ul style="list-style-type: none"> ▪ Pull out the star wheel (1) from the plain bearing (2) on the guiding cylinder (3). ▪ Check the condition of the star wheel (1) after cleaning. If the star wheel is damaged, replace it with a new one.
	<p>15</p>	<ul style="list-style-type: none"> ▪ Pull the detent bushing (1) off from the guiding cylinder (3) and remove all the balls (2). ▪ Check the condition of the detent bushing (1) and the balls (2) after cleaning. Replace any damaged parts with new ones.
	<p>16</p>	<ul style="list-style-type: none"> ▪ Unscrew the screws (1) inside the switching unit housing. ▪ Take the screws (1) and washers (2) and set them aside.

Figure	Step	Description
	<p>17</p>	<ul style="list-style-type: none"> ▪ Remove the connection flange (2) from the switching unit housing. ▪ Replace the O-ring (1) with a new, greased O-ring.
	<p>18</p>	<p>Use the screws (2) and washers (3) to mount the connection flange (1) back on the switching unit housing. Observe the tightening torque information provided in the table before this section.</p>
	<p>19</p>	<ul style="list-style-type: none"> ▪ Insert the lightly greased detent bushing (1) back into the guiding cylinder (3). Make sure that the detent bushing (1) is aligned correctly. The offset on the detent bushing's outside surface must point inwards into the guiding cylinder. ▪ Insert the greased balls (2) into the corresponding recesses on the guiding cylinder (3).
	<p>20</p>	<p>Move the star wheel (1) over and beyond the inserted balls in order to put it back on the plain bearing (2). Slide the star wheel (1) as far as it will go. When doing so, make sure to observe the correct alignment of the star wheel (1) inside the switching unit housing and relative to the balls as shown in the diagram to the left. Opening (3) is the position for the manual trigger. Opening (4) is the position for the spring-loaded pressure piece.</p>
	<p>21</p>	<p>Install the manual trigger (1) and the spring-loaded pressure piece (2) back inside the switching unit housing. Make sure to observe the correct alignment of the star wheel (3) inside the switching unit housing.</p> <p>IMPORTANT! The manual trigger's (1) control rod must not bear against the star wheel (3). Instead, there must be a gap between the manual trigger's control rod and the star wheel.</p>

Figure	Step	Description
	22	Take the valve shank unit (2) and the pinion shaft (1) and thread both components into the switching unit housing from the appropriate side.
	23	Use an Allen key (1) to screw the pinion shaft (2) and the valve shank unit (3) together. Observe the additional tightening torque and threadlocker specifications provided in the table before this section.
	24	Use the screws (1) and washers (2) to mount the switching unit housing's cover (3) back on the switching unit housing. Observe the tightening torque information provided in the table before this section.
	25	Remove the used O-ring from the valve plate.
	26	<ul style="list-style-type: none"> ▪ Insert a new, greased O-ring into the valve plate's groove. ▪ Press on the O-ring at several points evenly distributed along the circumference in order to push it into the groove. ▪ Then press everywhere on the O-ring in order to fully push it in.

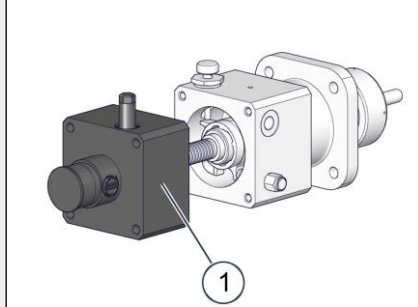
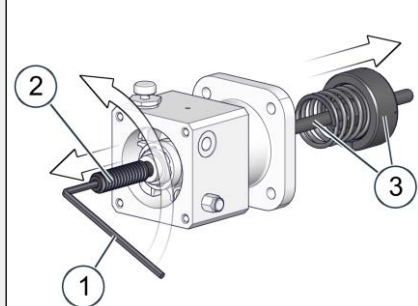
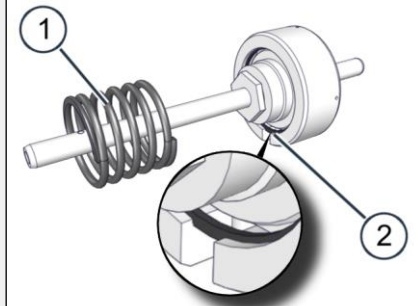
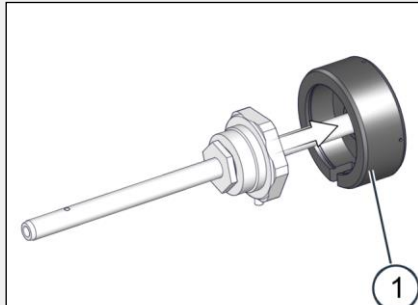
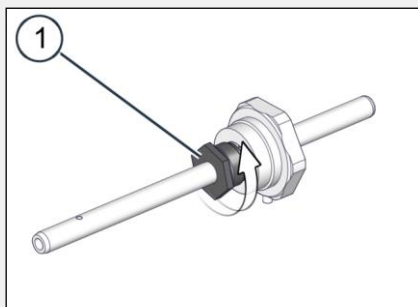
Next task

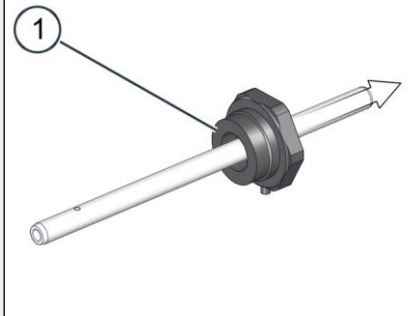
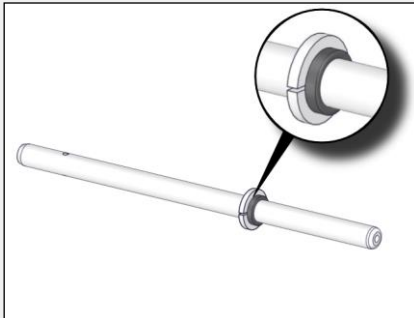
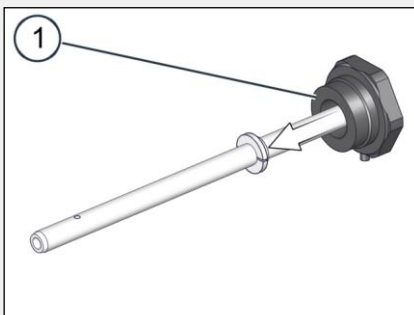
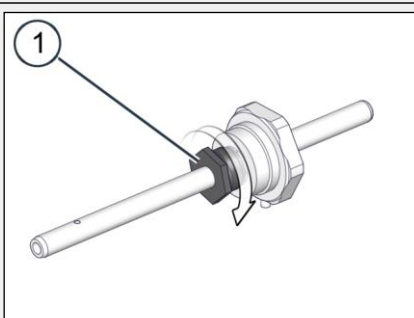
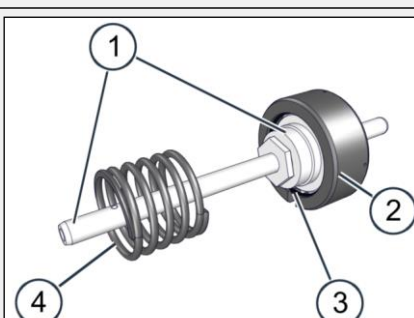
Proceed as follows:

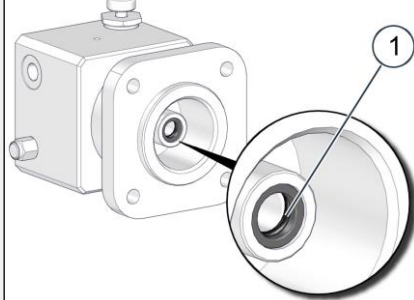
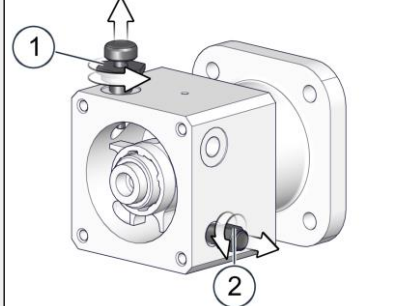
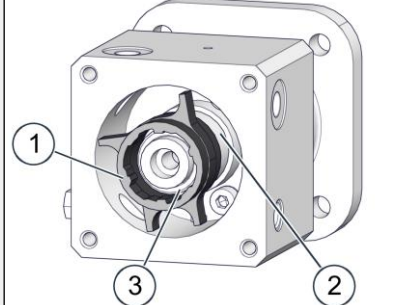
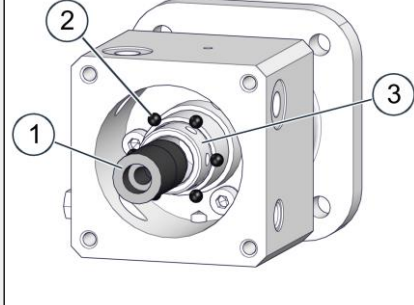
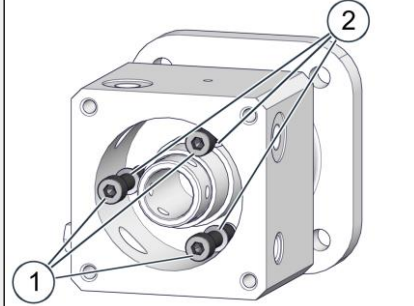
- *Installing the triggering unit - 2", 3", 4" size (see page 90)*

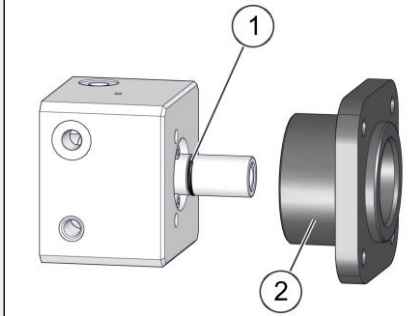
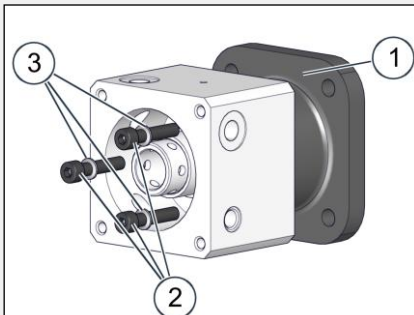
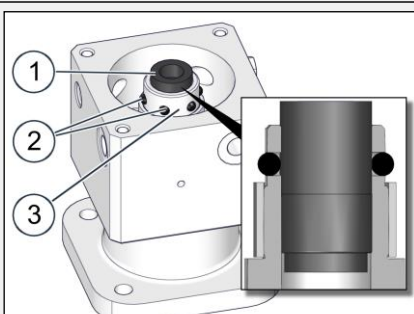
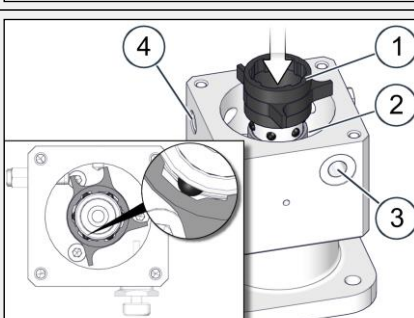
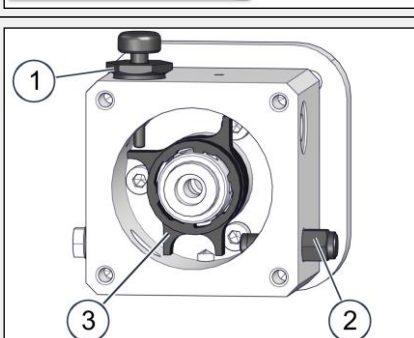
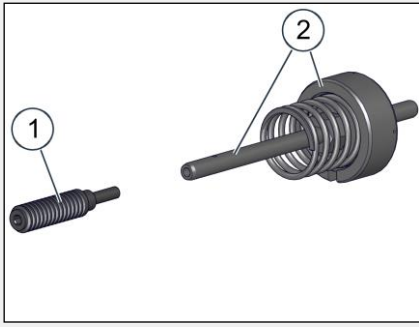
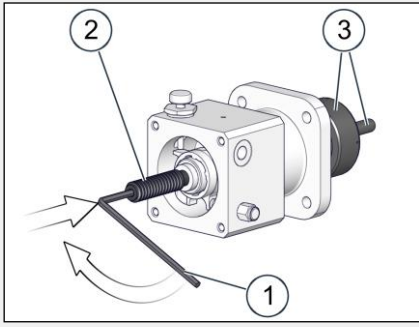
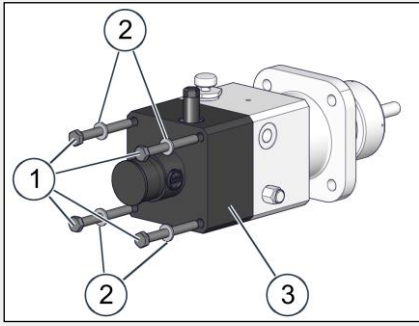
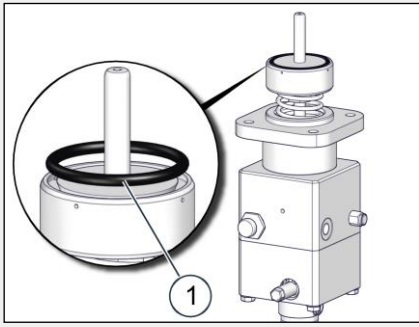
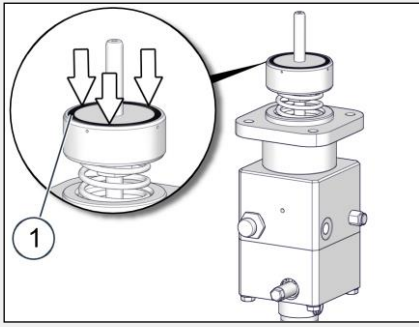
7.4.7 Maintaining the triggering unit - 6" size

Falling components



Crush and impact hazard posed by components falling or toppling over accidentally.

When working with heavy components that have been removed or are yet to be installed, injury may result if the components start moving in an uncontrolled manner, e.g., fall down from the working surface or topple over.

- ⇒ Place removed components exclusively on level, horizontal working surfaces with enough load-bearing capacity.
- ⇒ If necessary, secure removed components so that they will not fall or topple over.
- ⇒ Wear the required personal protective equipment.
- ⇒ Exercise caution when performing the relevant tasks.

Cleaning

Observe the following cleaning instructions:

- Before assembly, all parts must be cleaned in order to remove any foreign particles (swarf) and soiling.
- If screws, bolts, or washers are replaced with identical new parts, any oil on these new parts must first be removed.

Maintaining the triggering unit

Proceed as follows:

Figure	Step	Description
	1	<ul style="list-style-type: none"> ▪ Remove the sleeve (1) from the valve rod (2). ▪ Clean the valve rod and then grease it lightly, making sure to observe the lubricant table in the appendix.
	2	<ul style="list-style-type: none"> ▪ Take the two sleeves (1, 2). ▪ Replace the O-rings (3, 4, 5, 6) with new, lubricated O-rings.
	3	<p>Take the flap valve. Replace the O-ring (1) with a new, greased O-ring.</p> <ul style="list-style-type: none"> ▪ To do so, insert the new, greased O-ring into the valve disc's groove. ▪ Press on the O-ring at several points evenly distributed along the circumference in order to push it into the groove. ▪ Then press everywhere on the O-ring in order to fully push it in.

Next task

Proceed as follows:

- Maintaining the HON 910 push-button valve - 6" size (see page 86)
- Installing the triggering unit - 6" size (see page 91)

7.4.8 Maintaining the HON 910 push-button valve - 6" size

Cleaning

Observe the following cleaning instructions:

- Before assembly, all parts must be cleaned in order to remove any foreign particles (swarf) and soiling.
- If screws, bolts, or washers are replaced with identical new parts, any oil on these new parts must first be removed.

Tightening torques

Observe the tightening torques below when following the instructions in this section:

Part	Tightening torque	Step
Hex bolts	8 Nm (5.9 ft lbs)	10

Maintaining the HON 910 push-button valve

Proceed as follows:

Figure	Step	Description
	1	<ul style="list-style-type: none"> ▪ Unscrew the screws (1) on the push-button valve's housing. ▪ Take the screws (1) and washers (2) and set them aside.
	2	<ul style="list-style-type: none"> ▪ Remove the adapter plate (1) from the housing.
	3	<ul style="list-style-type: none"> ▪ Remove the compression spring (1) and the piston (2) from the housing. ▪ Replace the piston (2) with a new one.

Figure	Step	Description
	<p>4</p>	<ul style="list-style-type: none"> ▪ Unscrew the screws (1) on the push-button valve's control lever. ▪ Take the screws (1) and washers (2) and set them aside.
	<p>5</p>	<p>Remove the push-button valve's control lever (1).</p>
	<p>6</p>	<p>Push the pin (1) out of the housing.</p>
	<p>7</p>	<ul style="list-style-type: none"> ▪ Remove the pin (1) from the other side of the housing. ▪ Replace the O-ring (2) with a new, greased O-ring. ▪ Slide the pin (1) back into the hole on the housing as far as it will go.
	<p>8</p>	<p>Replace the O-rings (1, 2) with new, lubricated O-rings.</p>

Figure	Step	Description
	9	<ul style="list-style-type: none"> Insert the new piston (1) into the housing. Insert the compression spring (2) into the hole on the piston (1).
	10	<p>Use the screws (3) and washers (2) to mount the adapter plate (1) back on the housing.</p> <p>Observe the tightening torque information provided in the table before this section.</p>
	11	<p>Use the screws (1) and washers (2) to mount the control lever (3) back on the housing.</p>

7.4.9 Installing the triggering unit - 1" size

Falling components

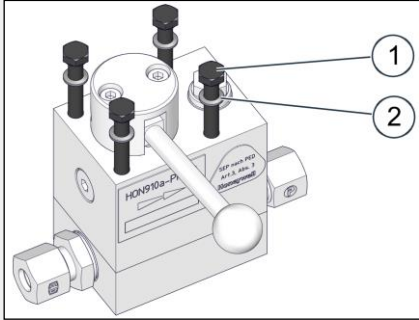
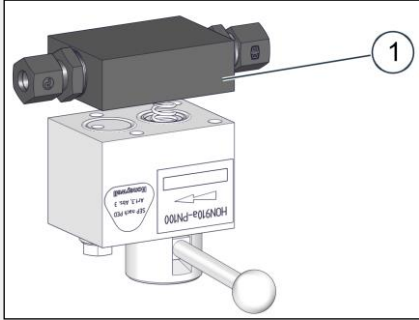
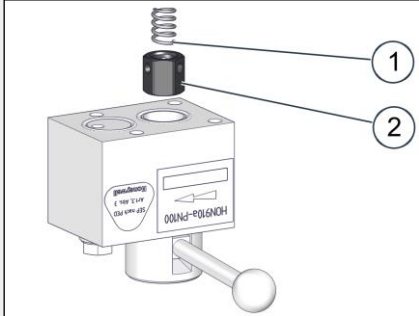

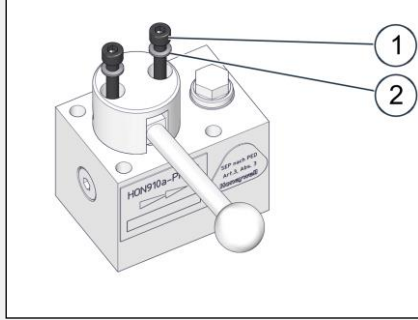
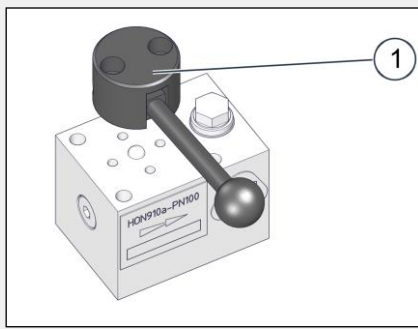
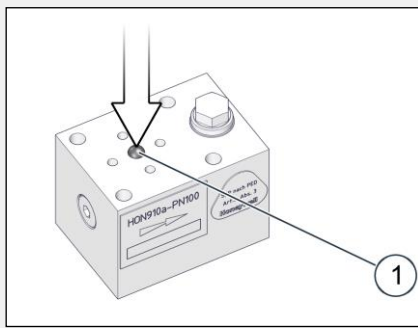
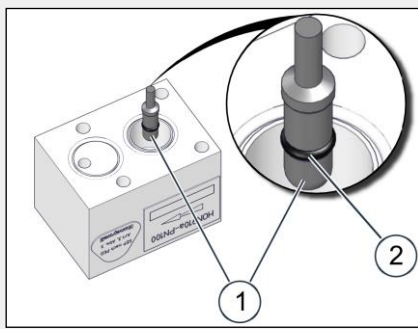
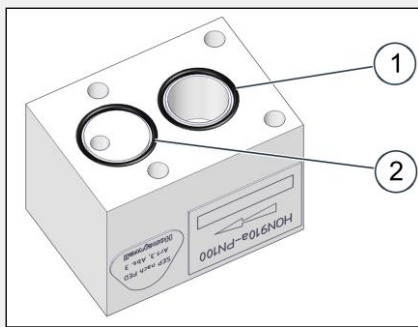
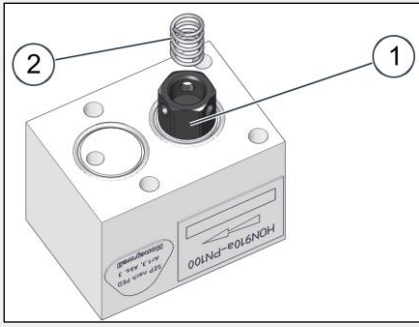
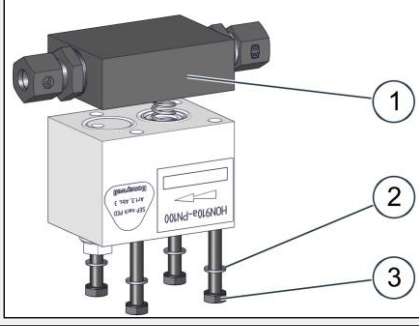
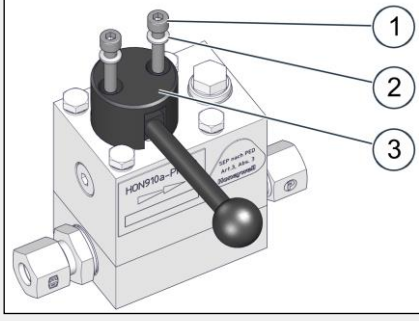
Crush and impact hazard posed by components falling or toppling over accidentally.

When working with heavy components that have been removed or are yet to be installed, injury may result if the components start moving in an uncontrolled manner, e.g., fall down from the working surface or topple over.

- ⇒ Place removed components exclusively on level, horizontal working surfaces with enough load-bearing capacity.
- ⇒ If necessary, secure removed components so that they will not fall or topple over.
- ⇒ Wear the required personal protective equipment.
- ⇒ Exercise caution when performing the relevant tasks.

Cleaning

Observe the following cleaning instructions:

- Before assembly, all parts must be cleaned in order to remove any foreign particles (swarf) and soiling.
- If screws, bolts, or washers are replaced with identical new parts, any oil on these new parts must first be removed.

Tightening torques

Observe the tightening torques below when following the instructions in this section:

Part	Tightening torque	Step
Screws	35 Nm (26 ft lbs)	3

Installing the triggering unit on the actuator assembly

Proceed as follows:

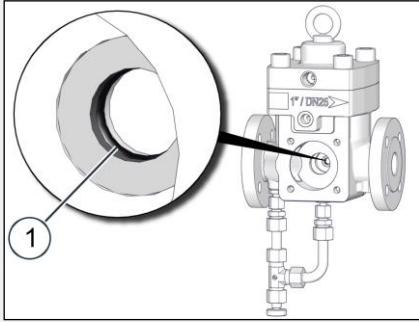
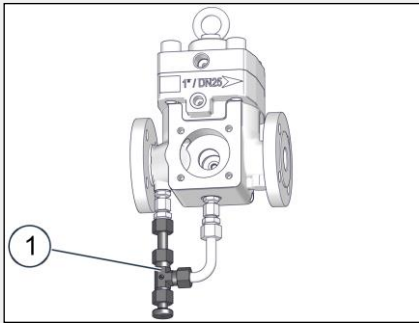
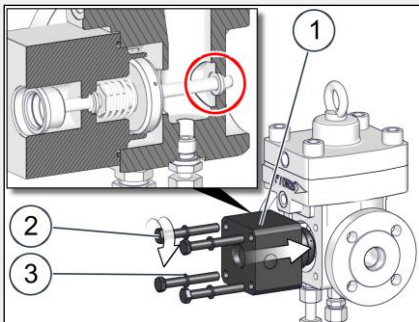
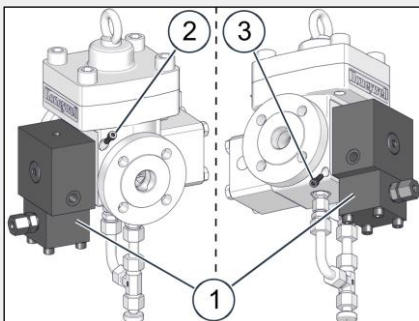
Figure	Step	Description
	1	Look into the actuator assembly from the side shown in the diagram to the left. Replace the O-ring (1) on the valve rod guide with a new, greased O-ring.
	2	Replace the pressure compensating valve (1) with a new one.
	3	<ul style="list-style-type: none"> ▪ Take the shut-off unit (1) and place it against the actuator assembly in a straight horizontal line. When doing so, make sure that the valve rod is threaded through the circled hole in the actuator assembly. ▪ Tighten the screws (2) with the washers (3) in a criss-cross sequence. Observe the tightening torque information provided in the table before this section.
	4	<ul style="list-style-type: none"> ▪ Take the switching unit (1) and place it against the actuator assembly. ▪ Use the screws (2, 3) to fasten the switching unit back on the actuator assembly.

7.4.10 Installing the triggering unit - 2", 3", 4" size

Falling components



Crush and impact hazard posed by components falling or toppling over accidentally.

When working with heavy components that have been removed or are yet to be installed, injury may result if the components start moving in an uncontrolled manner, e.g., fall down from the working surface or topple over.

- ⇒ Place removed components exclusively on level, horizontal working surfaces with enough load-bearing capacity.
- ⇒ If necessary, secure removed components so that they will not fall or topple over.
- ⇒ Wear the required personal protective equipment.
- ⇒ Exercise caution when performing the relevant tasks.

Cleaning

Observe the following cleaning instructions:

- Before assembly, all parts must be cleaned in order to remove any foreign particles (swarf) and soiling.
- If screws, bolts, or washers are replaced with identical new parts, any oil on these new parts must first be removed.

Special tools

Prepare the following special tools in addition to the standard tools:

Figure	Description
	Assembly aid (10026350)

Tightening torques

Observe the tightening torques below when following the instructions in this section:

Part	Tightening torque	Step
Hex nuts	30 Nm (22 ft lbs)	3

Installing the triggering unit on the actuator assembly

Proceed as follows:

Figure	Step	Description
	1	Look into the actuator assembly from below. Replace the O-ring (1) on the valve rod guide with a new, greased O-ring. Use the assembly aid intended for this purpose.

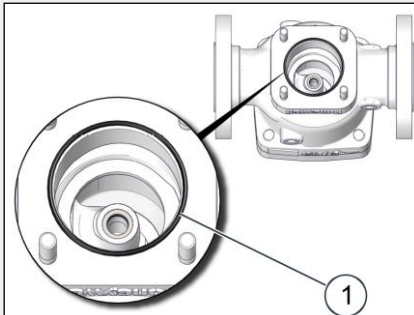
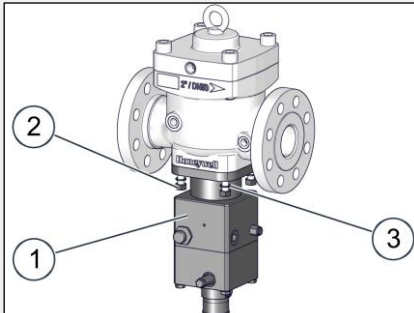
Figure	Step	Description
	2	Replace the O-ring (1) facing the connection flange with a new, greased O-ring.
	3	<ul style="list-style-type: none"> ▪ Take the triggering unit (1) and place it against the actuator assembly. ▪ Tighten the nuts (2) with the washers (3) in a criss-cross sequence. Observe the tightening torque information provided in the table before this section.

7.4.11 Installing the triggering unit - 6" size

Falling components



Crush and impact hazard posed by components falling or toppling over accidentally.

When working with heavy components that have been removed or are yet to be installed, injury may result if the components start moving in an uncontrolled manner, e.g., fall down from the working surface or topple over.

- ⇒ Place removed components exclusively on level, horizontal working surfaces with enough load-bearing capacity.
- ⇒ If necessary, secure removed components so that they will not fall or topple over.
- ⇒ Wear the required personal protective equipment.
- ⇒ Exercise caution when performing the relevant tasks.

Cleaning

Observe the following cleaning instructions:

- Before assembly, all parts must be cleaned in order to remove any foreign particles (swarf) and soiling.
- If screws, bolts, or washers are replaced with identical new parts, any oil on these new parts must first be removed.

Installation position for closing springs

The spring housing has two grooves, for the closing springs, cast into it. These grooves are required in order to be able to hold the closing springs as needed for the “operating side on the right” and “operating side on the left” configurations. When installing the closing springs, observe the layouts in the following table:

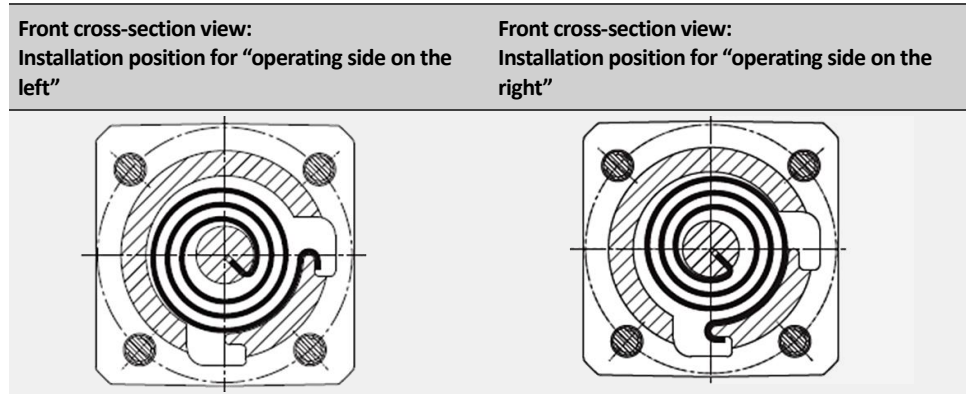

Note: The standard configuration for the assembly is “operating side on the left.” The illustrations in this document use this configuration.

Tightening torques

Observe the tightening torque and threadlocker specifications below when following the instructions in this section:

Part	Tightening torque	Threadlocker	Step
Hex bolts	10 Nm (7.4 ft lbs)	-	5
Cylinder screws	40 Nm (29.5 ft lbs)	LOCTITE 221	7
Cylinder screws	40 Nm (29.5 ft lbs)	LOCTITE 221	13
Socket cap screw	-	LOCTITE 221	14
Screws	-	LOCTITE 221	17
Screws	350 Nm (258 ft lbs)	-	19
Fittings	-	LOCTITE 221	23

Installing the triggering unit on the actuator assembly

Proceed as follows:

Figure	Step	Description
	1	<ul style="list-style-type: none"> ▪ Look into the actuator assembly from below. ▪ Take the shorter of the two sleeves (1) and insert it into the appropriate hole inside the actuator assembly on the spring housing side.

Figure	Step	Description
	2	<ul style="list-style-type: none"> ▪ Insert the key (2) into the valve rod (1). ▪ Move the flap valve (3) to the closed position inside the actuator assembly. ▪ Starting from the switching unit side, slide the valve rod with the key through the actuator assembly body, the flap valve, and the sleeve. While doing so, make sure that the valve rod and the key are aligned correctly.
	3	<ul style="list-style-type: none"> ▪ Slide the sleeve (1) onto the valve rod (2) on the switching unit side. ▪ Slide the sleeve further until it is solidly seated in the corresponding recess (3) inside the actuator assembly body.
	4	<ul style="list-style-type: none"> ▪ On the switching unit side, install the retaining ring (1) on the valve rod (2). ▪ Then move the valve rod (2) until the retaining ring (1) is solidly seated in the recess (3) on the sleeve.
	5	<ul style="list-style-type: none"> ▪ Screw in the screws (1) for the flap valve inside the actuator assembly body. Observe the tightening torque information provided in the table before this section.
	6	<ul style="list-style-type: none"> ▪ Take the cleaned switching unit housing (1) together with its components: <ul style="list-style-type: none"> ▪ Ring (2) ▪ Rollers (3) ▪ Key (4) ▪ Retaining ring (5) ▪ Detent bushing (6) ▪ Slide the ring (2) over the guiding cylinder (7) and as far as it will go inside the switching unit housing.

Figure	Step	Description
	7	<ul style="list-style-type: none"> ▪ Slide the switching unit housing (1) from the appropriate side onto the valve rod (5). ▪ Place the switching unit housing (1) against the surface that is milled flat (2) on the actuator assembly body. ▪ Use the four screws (3) and washers (4) to fasten the switching unit housing (1) onto the actuator assembly body. Observe the additional tightening torque and threadlocker specifications provided in the table before this section.
	8	<p>Insert the key (1), with a bit of grease, into the corresponding recess on the valve rod (2).</p>
	9	<ul style="list-style-type: none"> ▪ Slide the detent bushing (5) into the guiding cylinder (1) and onto the valve rod (3) as far as it will go. ▪ Insert the retaining ring (4) into the corresponding recess on the detent bushing (5). ▪ Insert the greased rollers (2) into the corresponding recesses on the guiding cylinder (1).
	10	<p>Use the screw (2) to secure the washer (1) back on the valve rod (3) inside the switching unit housing.</p>
	11	<p>Take the spring housing (1) and insert the closing springs (2) as shown in the diagram to the left. Observe the additional closing spring alignment specifications provided in the table before this section.</p>

Figure	Step	Description
	<p>12</p>	<ul style="list-style-type: none"> ▪ Hold the flap valve (1) in its closed position. ▪ Take the spring housing (4) and hold it in a slightly turned position as shown in the diagram to the left. ▪ Thread the closing springs' inner straight ends into the corresponding groove (3) on the valve rod while sliding the spring housing onto the valve rod.
	<p>13</p>	<ul style="list-style-type: none"> ▪ Use the re-engaging lever (3) to rotate the spring housing (3) approx. one quarter of a turn counterclockwise. ▪ Slide the spring housing, in the required rotated position, all the way against the surface milled flat on the actuator assembly body. ▪ Tighten the screws (1) with the washers (2) in a criss-cross sequence. Observe the additional tightening torque and threadlocker specifications provided in the table before this section.
	<p>14</p>	<ul style="list-style-type: none"> ▪ Place the opening element (3) on the valve rod in the position shown in the diagram to the left. ▪ Use the screw (1) to secure the washer (2) back on the valve rod. Observe the additional threadlocker specifications provided in the table before this section.
	<p>15</p>	<ul style="list-style-type: none"> ▪ Check the condition of the star wheel (2) after cleaning. If the star wheel is damaged, replace it with a new one. ▪ Hold the flap valve (1) in its closed position. ▪ Slide the star wheel (2) over the inserted rollers and onto the plain bearing as far as it will go. When doing so, make sure to observe the correct alignment of the star wheel (2) inside the switching unit housing.
	<p>16</p>	<p>Install the manual trigger (1) and the spring-loaded pressure piece (2) back inside the switching unit housing. Make sure to observe the correct alignment of the star wheel inside the switching unit housing.</p> <p>IMPORTANT! The manual trigger's (1) control rod must not bear against the star wheel. Instead, there must be a gap between the manual trigger's control rod and the star wheel.</p>

Figure	Step	Description
 <p>A perspective view of the switching unit housing. Callout 1 points to a washer on the side of the housing. Callout 2 points to a screw being inserted into the side. Callout 3 points to the switching unit housing cover being attached to the side.</p>	<p>17</p>	<p>Use the screws (2) and washers (1) to mount the switching unit housing's cover (3) back on the switching unit housing. Observe the additional threadlocker specifications provided in the table before this section.</p>
 <p>A view of the actuator assembly from below. Callout 1 points to an O-ring located in a groove on the bottom flange of the actuator.</p>	<p>18</p>	<p>Look at the actuator assembly from below. Replace the O-ring (1) with a new, greased O-ring.</p>
 <p>A perspective view of the bottom cover assembly. Callout 1 points to the bottom cover being mounted. Callout 2 points to a washer on the side. Callout 3 points to a screw being inserted into the side.</p>	<p>19</p>	<p>Use the screws (3) and washers (2) to mount the bottom cover (1) back onto the actuator assembly. Observe the tightening torque information provided in the table before this section.</p>
 <p>A close-up view of the re-engaging lever assembly. Callout 1 points to the re-engaging lever being pulled downwards and outwards from the spring housing.</p>	<p>20</p>	<p>Pull the re-engaging lever (1), against the slight resistance that will be produced, downwards and out from the spring housing.</p>
 <p>A close-up view of the re-engaging lever assembly. Callout 1 points to the re-engaging lever being inserted into the opening. Callout 2 points to the opening element.</p>	<p>21</p>	<ul style="list-style-type: none"> ▪ Insert the re-engaging lever (1) into the opening on the opening element (2). ▪ Turn the re-engaging lever (1) counter-clockwise until you feel the flap valve lock into place.

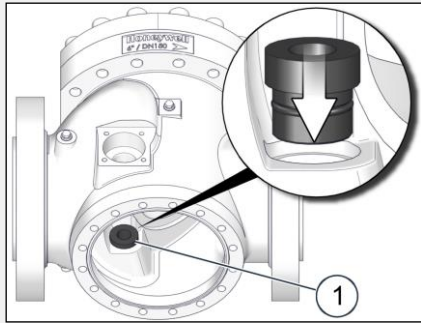
Figure	Step	Description
 <p>A technical drawing of a valve assembly. A circular inset shows a close-up of a re-engaging lever (labeled '1') being inserted into a specific opening on the side of the valve's spring housing. The lever is a dark, wedge-shaped component.</p>	<p>22</p>	<p>Insert the re-engaging lever (1), against the slight resistance that will be produced, back into the opening on the spring housing.</p>
 <p>A technical drawing of the same valve assembly. A pressure compensating valve (labeled '1') is shown being installed onto a port on the side of the valve. The valve is a small, cylindrical component with a handle.</p>	<p>23</p>	<p>Install the maintained or new pressure compensating valve (1). Observe the additional threadlocker specifications provided in the table before this section.</p>

7.5 Completing the maintenance

Protecting the pipe connections from being twisted

When conducting work involving the pipework, please always observe the following:

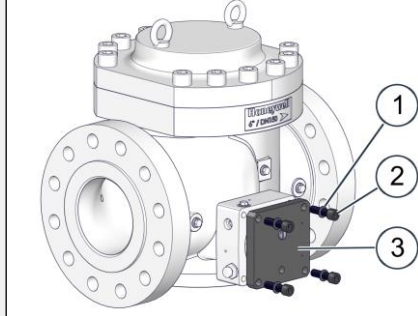
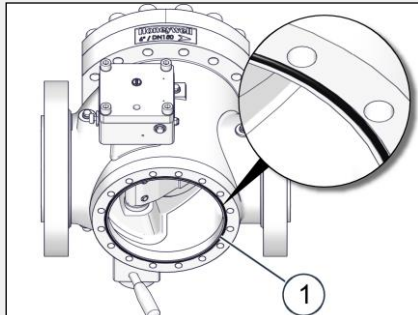
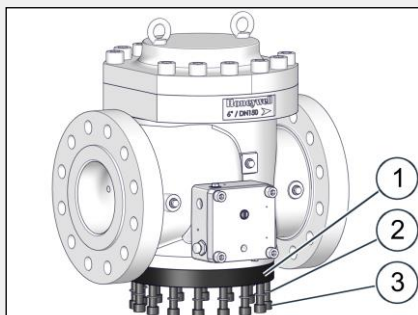
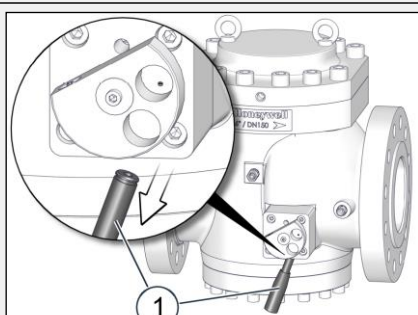
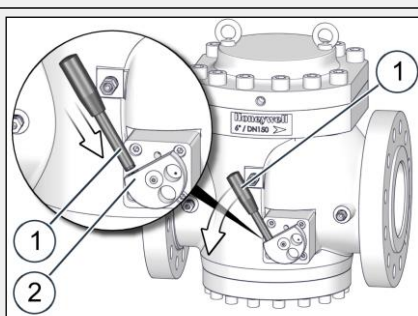
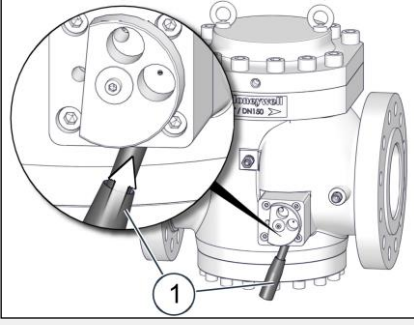
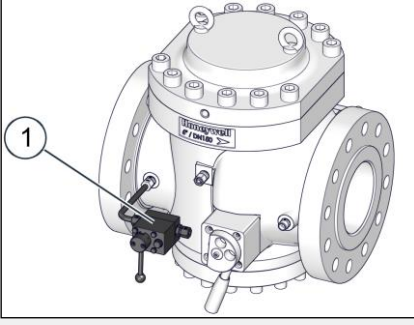
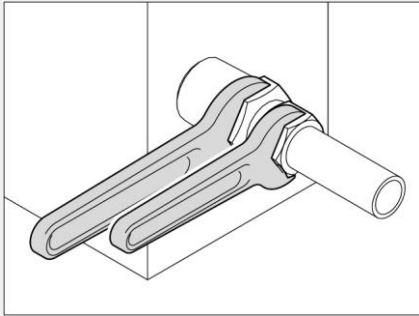
Figure	Description
	<p>Do not twist the pipe connections in the assemblies. Use a second spanner wrench for securing when loosening and tightening pipe joints.</p>

Installing components

To install the pilot, follow the steps below:

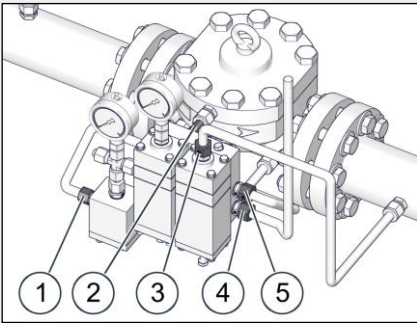
Figure	Step	Description
	1	<p>Reinstall all the pipes you removed previously on the actuator assembly.</p> <ul style="list-style-type: none"> ▪ Inlet pressure line (1) ▪ Motorization line (2) ▪ Outlet pressure line (5)
	2	<p>Reinstall all the pipes you removed previously on the pilot.</p> <ul style="list-style-type: none"> ▪ Inlet pressure line (1) ▪ Motorization line (2) ▪ Measuring line (3) ▪ Vent line (4) ▪ Outlet pressure line (5) <p>Result: The pilot is now installed on the actuator assembly and in the gas regulating line.</p>

To install the monitoring device, follow the steps below (version with HON 670 / 671):

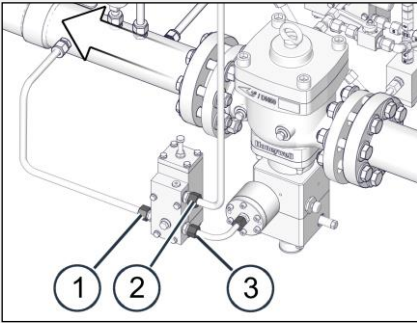
Figure	Step	Description
	1	<p>Reinstall all the pipes you removed previously on the monitoring device and on the pressure unit.</p> <ul style="list-style-type: none"> ▪ Vent line (2) ▪ Outlet pressure line (1) ▪ Monitoring device / pressure unit connection line (3) <p>Result: The monitoring device and the pressure unit are now installed on the SAV actuator and in the gas regulating line.</p>

To install the monitoring device, follow the steps below (version with HON 672):

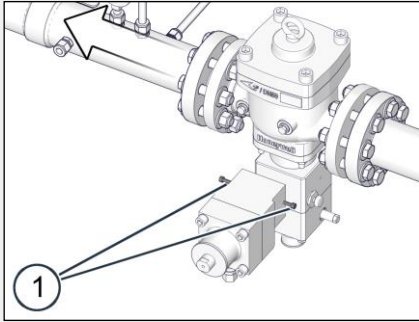
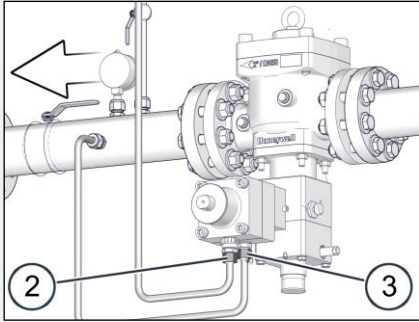
Figure	Step	Description
	<p>1</p>	<p>Reinstall all the fittings (1) you removed previously on the monitoring device.</p> <p>Result:</p> <p>The monitoring device is now installed on the SAV actuator.</p>
	<p>2</p>	<p>Reinstall all the pipes you removed previously on the monitoring device.</p> <ul style="list-style-type: none"> ▪ Vent line (2) ▪ Outlet pressure line (3) <p>Result:</p> <p>The monitoring device is now installed on the SAV actuator and in the gas regulating line.</p>

To install the monitoring device, follow the steps below (version with HON 673):

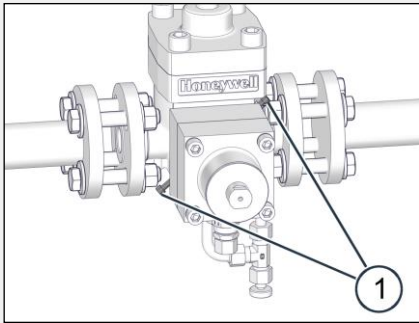
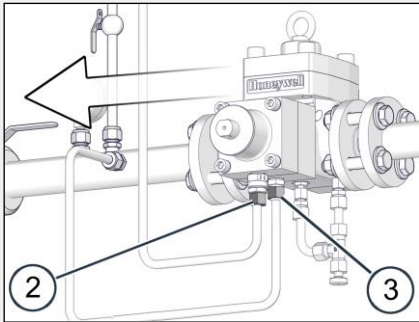
Figure	Step	Description
	<p>1</p>	<p>Reinstall all the fittings (1) you removed previously on the monitoring device.</p> <p>Result:</p> <p>The monitoring device is now installed on the actuator assembly.</p>
	<p>2</p>	<p>Reinstall all the pipes you removed previously on the monitoring device.</p> <ul style="list-style-type: none"> ▪ Vent line (2) ▪ Outlet pressure line (3) <p>Result:</p> <p>The monitoring device is now installed on the SAV actuator and in the gas regulating line.</p>

To install the pressure unit, follow the steps below (HON 670 / 671 model):

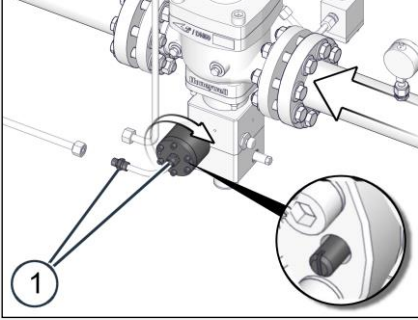
Figure	Step	Description
	1	Reinstall the pressure unit you removed previously on the actuator assembly. Tighten the set screw.
	2	Reinstall all the pipes you removed previously on the pressure unit*: <ul style="list-style-type: none"> ▪ Monitoring device / pressure unit connection line (1) Result: The pressure unit is now installed on the SAV actuator and in the gas regulating line.

Next task

Proceed as follows:

Checking the system for leaks

8 Storage and disposal

Contents

Topic	Page
Storing the device	101
Disassembling the device	101
Disposing of the device	103

8.1 Storing the device

Storage of the packing units

Observe the following rules:

- Do not store the device outdoors.
- Store the device in a dry and dust-free environment on a flat surface.
- Do not expose the device to any aggressive media, ozone or ionizing radiation or to direct heat sources.
- Storage conditions:
 - Temperature: 32 °F to 77 °F (0 °C to 25 °C)
 - Relative humidity: < 55 %.
- Avoid mechanical vibrations.
- Storage periods:
 - When storing the device for up to one year:
Store the device in its original packaging and in the same condition it was delivered. All protective caps of the device must remain in place.
 - When storing the device for more than one year (e.g., as a backup device):
Store the device in its original packaging and in the same condition it was delivered and check it annually for damage and soiling. Consider the storage period in the maintenance cycles.

Note: Please also observe any storage information provided on the packaging.

Storage of spare parts

The following rules apply to the storage of spare parts:

- Apply an appropriate protective agent to assemblies at risk of corrosion.
 - If stored correctly, O-rings and gaskets should not be kept longer than 7 years.
 - Store the spare parts in the original package until they are used.
-

8.2 Disassembling the device

Pressurized parts



Risk of serious injury posed by pressurized components moving in an uncontrolled manner when handled improperly.

If not handled properly or in the event of a defect, gas can escape from pressurized components under high pressure and cause serious injuries and even death. Before you start working on these components:

- ⇒ Close all connections leading to the gas-carrying line.
 - ⇒ Establish a depressurized status. Residual amounts of energy must be depressurized as well.
-

Overview

The test setup is as follows (schematic diagram, using the two-stage HON 630 pilot with a diaphragm assembly and an HON 670 / 671 monitoring device as a reference):

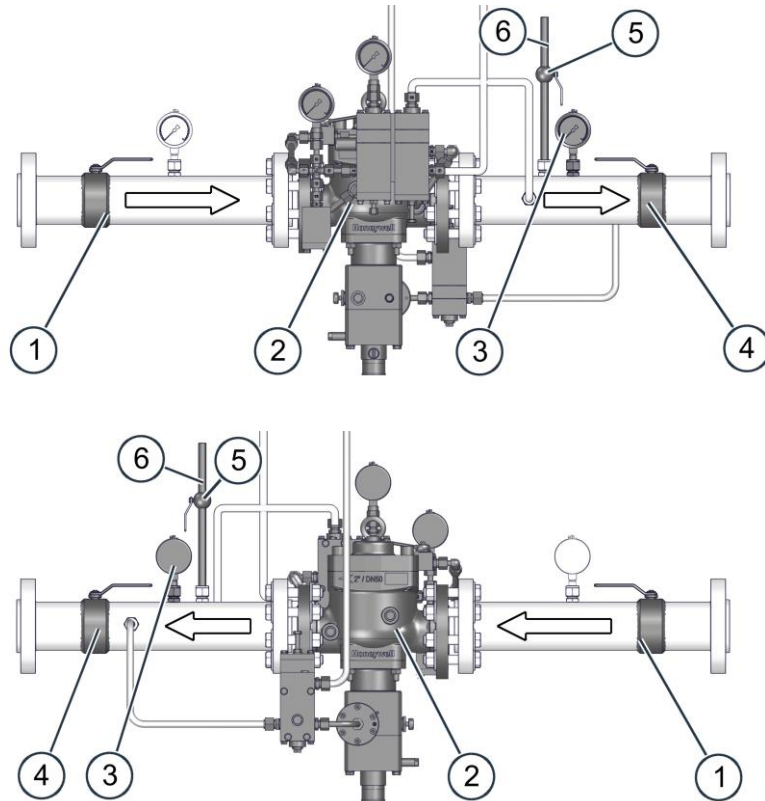

The numbers have the following meaning:

No.	Meaning
1	Inlet stop valve armature
2	Gas pressure regulator
3	Pressure gauge
4	Outlet stop valve armature
5	Valve for blowdown line
6	Blowdown line

Establishing the depressurized status

Proceed as follows:

Step	Description
1	Close the outlet stop valve armature (4).
2	Close the inlet stop valve armature (1).
3	Depressurize the pilot: Turn the set screw on the pilot's control stage – and the set screw on the pilot's load limiting stage as well if applicable – clockwise until the pressure in the pilot is equalized.
4	Open the ball valve (5) in the blowdown line (6) to discharge the pressure between the inlet and the outlet valves.
5	Depressurize the monitoring device: Close the outlet and inlet shut-off devices and open the ball valve in the blowdown line. This will cause the gas to blow out completely and depressurize the monitoring device.

Protecting the pipe connections from being twisted

When conducting work involving the pipework, please always observe the following:

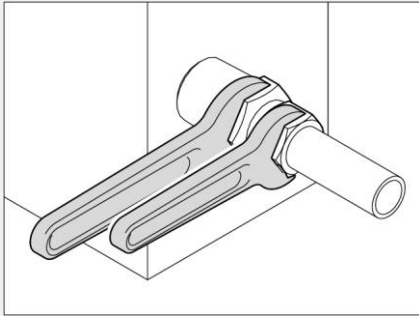
Figure	Description
	<p>Do not twist the pipe connections in the assemblies. Use a second spanner wrench for securing when loosening and tightening pipe joints.</p>

Purging the lines with nitrogen

All the gas pressure regulator's lines must be purged with nitrogen before the device is removed.

Disassembling the device

Proceed as follows:

Step	Description
1	Disassemble the device. Observe the information and instructions in the <i>Transport and installation</i> (see page 32) section when doing so.

8.3 Disposing of the device

Appropriate disposal

Comply with the legally stipulated disposal rules. Observe the following details pertaining to the appropriate disposal (not all of the items may be applicable to your device):

- Dispose of the metals according to their types and grades (steel scrap, cast iron scrap, light alloy scrap, nonferrous heavy metal scrap, synthetic rubber scrap, electronic scrap).
- Recycle elements made of synthetic materials.
- Dispose of any other components according to the quality of the materials.

9 Appendix

Contents

Topic	Page
Additional information regarding spare parts	104
Spare parts for actuator assembly with triggering unit - 1" size	105
Spare parts for actuator assembly with triggering unit - 2", 3", 4" size	108
Spare parts for actuator assembly with triggering unit - 6" size	121
Spare parts for HON 910 push-button valve for actuator assembly with 6" size	124
Spare parts for travel indication option	125
Lubricants	126

9.1 Additional information regarding spare parts

Spare parts categories

Spare parts fall into the following categories:

Spare parts category	Definition
Maintenance part	Spare parts that always have to be replaced during maintenance.
Servicing parts	Spare parts that need to be checked during maintenance and that must be replaced if necessary due to their condition.
	Spare parts that qualified personnel employed by the company operating the device is allowed to replace in order to convert the device (e.g., when changing the pressure range).
	Spare parts that qualified personnel employed by the company operating the device is allowed to replace in the event of a fault or defect.
Miscellaneous spare part	Parts that are listed in the spare part drawings in addition to maintenance and servicing parts so as to improve communications between the customer and the manufacturer, but that are not allowed to be ordered or replaced without first contacting the manufacturer.

Maintenance and servicing parts for actuator assembly

- The spare parts always required for the actuator assembly's maintenance are grouped together into spare parts kits appropriate for the device in question. Each spare parts kit has its own part number.
- Individual servicing parts can be ordered by using the corresponding part number, which is specified in the bill of materials for the actuator assembly. The required number of parts is specified in the "Quantity" column.

Maintenance and servicing parts for travel indication (optional)

- The bill of materials for the travel indication is broken down into maintenance parts and servicing parts.
- The required number of maintenance or servicing parts is indicated under the relevant part number in the "Part No." column. If no quantity is specified, this means that only one unit is required.

Overview of bills of materials

The bills of materials are subdivided as follows:

- HON 5020 actuator assembly
 - Maintenance and servicing parts
 - Various spare parts kits, grouped by nominal size and pressure rating
- Push button valve HON 910 for actuator assembly, size 6"
 - Maintenance parts
- Travel indication option
 - Maintenance and servicing parts

9.2 Spare parts for actuator assembly with triggering unit - 1" size

Spare parts drawing for actuator assembly with triggering unit - 1" size

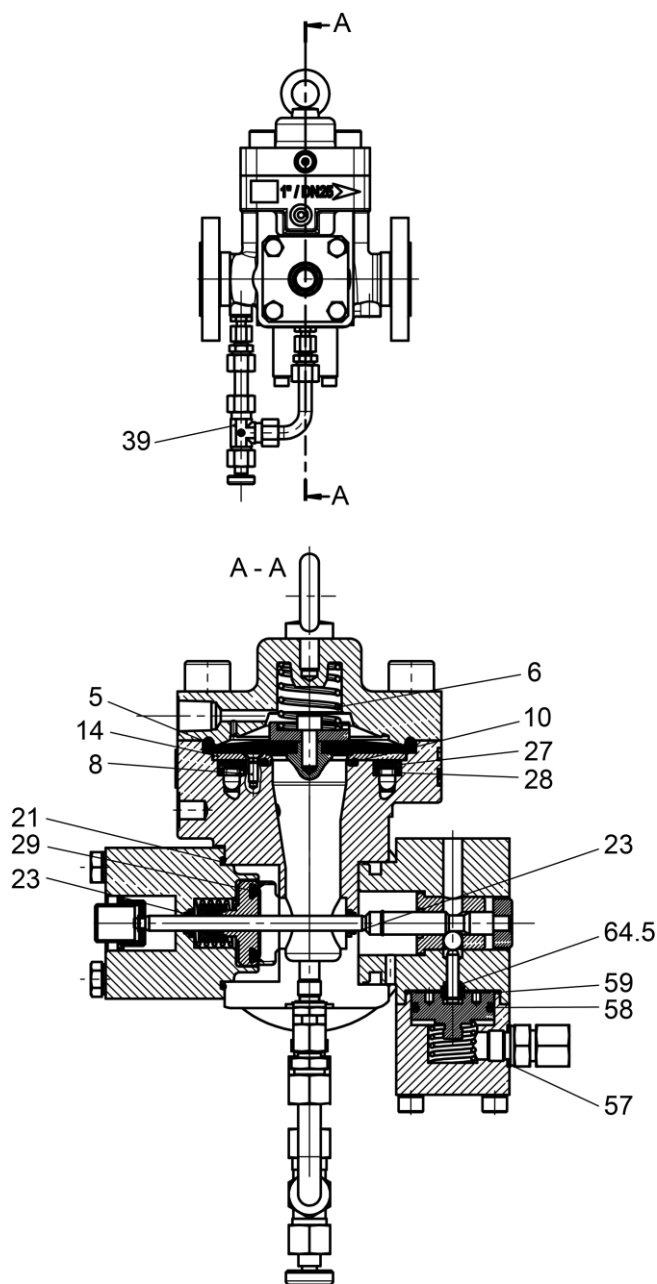

Maintenance and servicing parts for actuator assembly with triggering unit - 1" size

Nominal size	No. / Letter	Qty	Name	Part no.
1"	5	1	Diaphragm, up to 50 / 70 DP	201/MJ/001

Nominal size	No. / Letter	Qty	Name	Part no.
1"	6	1	Closing spring	18358049
1"	8	4	Screws	710BCFE03010
1"	10	1		
			O-ring NBR	730OAVN224
			Low-temperature NBR O-ring	730ODVN224
			O-ring FKM	730OMVV224
1"	14	1		
			Flow restrictor, 100%	201/MZ/001
			Flow restrictor, 75%	201/MZ/004
			Flow restrictor, 50%	201/MZ/006
			Flow restrictor 25%	201/MZ/008
1"	21	1		
			O-ring NBR	20461-RMK
			O-ring FKM	20750
			Low-temperature NBR O-ring	20758
1"	23	2		
			O-ring	20658-RMK
			Low-temperature O-ring	100445
1"	27	1	Carrier plate	201/MN/001
1"	28	1	Metal foam	201/MF/001
1"	29	1		
			O-ring	20572
			Low-temperature O-ring	20757
1"	39	1		
			HON 913A push-button valve, standard, NBR	10005200
			HON 913A push-button valve, stainless steel, NBR	18356919
			HON 913A push-button valve, low-temperature, stainless steel	18361700
			HON 913A push-button valve, low-temperature, standard	18361701
1"	57	1	Gasket	18842-RMK
1"	58	1		
			O-ring NBR	20336
			O-ring FKM	20599
			Low-temperature O-ring	100967-RMK

Nominal size	No. / Letter	Qty	Name	Part no.
1"	59	1	O-ring NBR	20398
			O-ring FKM	21114-RMK
			Low-temperature O-ring	100968-RMK
1"	64.5	1	O-ring NBR	20226-RMK
			O-ring FKM	20751-RMK
			Low-temperature O-ring	100991-RMK

Spare parts kits for actuator assembly with triggering unit - 1" size

Nominal size	No. / Letter	Qty	Name	Part no.
1"			1" 5020 R300 series spare parts kit (standard model) -NBR Class 300/600	K5020-001
	5	1	Diaphragm, up to 50 / 70 DP	201/MJ/001
	10	1	O-ring NBR	730OAVN224
	21	1	O-ring NBR	20461-RMK
	23	2	O-ring	20658-RMK
	29	1	O-ring	20572
	57	1	Gasket	18842-RMK
	58	1	O-ring NBR	20336
	59	1	O-ring NBR	20398
	64.5	1	O-ring NBR	20226-RMK

Nominal size	No. / Letter	Qty	Name	Part no.
1"			1" 5020 R300 series spare parts kit (FKM/NBR model) Class 300/600	K5020-003
	5	1	Diaphragm, up to 50 / 70 DP	201/MJ/001
	10	1	O-ring FKM	730OMVV224
	21	1	O-ring FKM	20750
	23	2	O-ring	20658-RMK
	29	1	O-ring	20572
	57	1	Gasket	18842-RMK
	58	1	O-ring FKM	20599
	59	1	O-ring FKM	21114-RMK
	64.5	1	O-ring FKM	20751-RMK

Nominal size	No. / Letter	Qty	Name	Part no.
1"			1" 5020 R300 series spare parts kit (low-temperature model) Class 300/600	K5020-002
	5	1	Diaphragm, up to 50 / 70 DP	201/MJ/001
	10	1	Low-temperature NBR O-ring	730ODVN224
	21	1	Low-temperature NBR O-ring	20758
	23	2	O-ring	100445
	29	1	O-ring	20752
	57	1	Gasket	18842-RMK
	58	1	Low-temperature O-ring	100967-RMK
	59	1	Low-temperature O-ring	100968-RMK
	64.5	1	Low-temperature O-ring	100991-RMK

9.3 Spare parts for actuator assembly with triggering unit - 2", 3", 4" size

Spare parts drawing for actuator assembly without triggering unit - size of 2", 3", or 4"

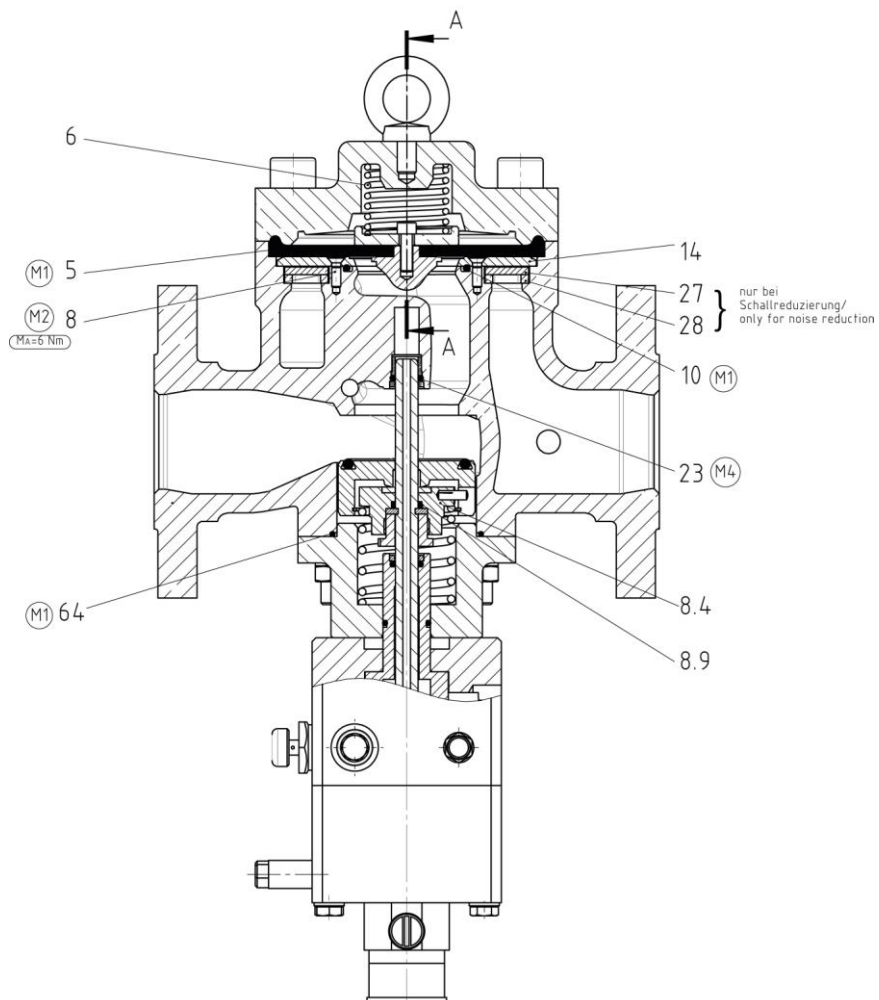

Spare parts drawing for triggering unit for actuator assembly - size of 2", 3", or 4"

DN80, DN100

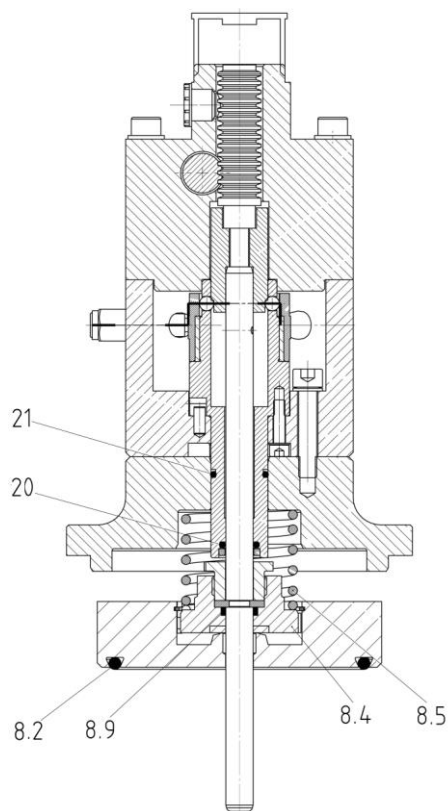

DN50

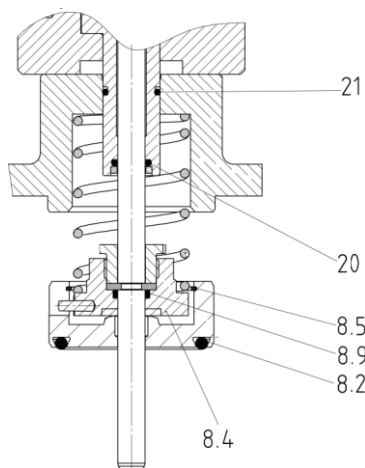

Maintenance and servicing parts for actuator assembly with triggering unit - size of 2", 3", or 4"

Nominal size	No. / Letter	Qty	Name	Part no.
2"	5	1	Diaphragm, up to 50 bar DP	202/MJ/012
			Diaphragm, up to 70 bar DP	202/MJ/013
2"	10	1	O-ring NBR	730OAVN229
			Low-temperature O-ring	730ODVN229
			O-ring FKM	730OMVV229
2"	6	1	Closing spring	SS1075
2"	8	4	Screws	710BCFE03010
2"	14	1	Flow restrictor, 100%	202/MZ/011
			Flow restrictor, 75%	202/MZ/019
			Flow restrictor, 50%	202/MZ/013
			Flow restrictor 25%	202/MZ/020
2"	27	1	Carrier plate	202/MN/001
2"	28	1	Metal foam	202/MF/001
2"	23	1		

Nominal size	No. / Letter	Qty	Name	Part no.
			Standard O-ring	20752-RMK
			Low-temperature O-ring	101461
2"	64	1		
			Low-temperature O-ring, DN50	102063-RMK
			O-ring NBR DN50	20246-RMK
			O-ring FKM DN50	20655-RMK
2"	8.4	1		
			Vulcanized NBR valve plate	10008606
			Vulcanized low-temperature valve plate	18355630
			Vulcanized FKM valve plate	18356878
	8.9	1		
			O-ring NBR	20412
			Low-temperature O-ring	101469-RMK
			O-ring FKM	20914
2"	8.2	1		
			O-ring NBR DN50	20596-RMK
			O-ring FKM DN50	20377
			Low-temperature O-ring, DN50	101566-RMK
2"	8.5	1	SB 55 circlip	19127
2"	20	1		
			Standard O-ring	20752-RMK
			Low-temperature O-ring	101461
2"	21	1		
			O-ring NBR	20383
			O-ring FKM	20913
			Low-temperature O-ring	101462-RMK
3"	5	1		
			Diaphragm, up to 50 bar DP	203/MJ/013
			Diaphragm, up to 70 bar DP	203/MJ/014
3"	10	1		
			O-ring NBR	730OAVN238
			Low-temperature O-ring	730ODVN238
			O-ring FKM	730OMVV238
3"	6	1	Closing spring	SS1293
3"	8	6	Screws	710BCFE03010

Nominal size	No. / Letter	Qty	Name	Part no.
3"	14	1	Flow restrictor, 100%	203/MZ/010
			Flow restrictor, 75%	203/MZ/018
			Flow restrictor, 50%	203/MZ/012
			Flow restrictor 25%	203/MZ/019
3"	27	1	Carrier plate	203/MN/001
3"	28	1	Metal foam	203/MF/001
3"	23	1	Standard O-ring	20752-RMK
			Low-temperature O-ring	101461
3"	64	1	Low-temperature O-ring, DN80/100	101460-RMK
			O-ring NBR DN80/100	20427
			O-ring FKM DN80/100	20910-RMK
3"	8.4	1	Vulcanized NBR valve plate	10008606
			Vulcanized low-temperature valve plate	18355630
			Vulcanized FKM valve plate	18356878
3"	8.9	1	O-ring NBR	20412
			Low-temperature O-ring	101469-RMK
			O-ring FKM	20914
3"	8.2	1	O-ring NBR DN80/100	20268-RMK
			O-ring FKM DN80/100	20640-RMK
			Low-temperature O-ring, DN80/100	101341-RMK
3"	8.5	1	SB 55 circlip	19127
3"	20	1	Standard O-ring	20752-RMK
			Low-temperature O-ring	101461
3"	21	1	O-ring NBR	20383
			O-ring FKM	20913
			Low-temperature O-ring	101462-RMK
4"	5	1		

Nominal size	No. / Letter	Qty	Name	Part no.
			Diaphragm, up to 50 bar DP	204/MJ/003
			Diaphragm, up to 70 bar DP	204/MJ/004
4"	10	1		
			O-ring NBR	730OAVN244
			Low-temperature O-ring	730ODVN244
			O-ring FKM	730OMVV244
4"	6	1	Closing spring	10024055
4"	8	6	Screws	710BCFE03010
4"	14	1		
			Flow restrictor, 100%	204/MZ/010
			Flow restrictor, 75%	204/MZ/016
			Flow restrictor, 50%	204/MZ/012
			Flow restrictor 25%	204/MZ/017
4"	27	1	Carrier plate	204/MN/002
4"	28	1	Metal foam	204/MF/001
4"	23	1		
			Standard O-ring	20752-RMK
			Low-temperature O-ring	101461
4"	64	1		
			Low-temperature O-ring, DN80/100	101460-RMK
			O-ring NBR DN80/100	20427
			O-ring FKM DN80/100	20910-RMK
4"	8.4	1		
			Vulcanized NBR valve plate	10008606
			Vulcanized low-temperature valve plate	18355630
			Vulcanized FKM valve plate	18356878
	8.9	1		
			O-ring NBR	20412
			Low-temperature O-ring	101469-RMK
			O-ring FKM	20914
4"	8.2	1		
			O-ring NBR DN80/100	20268-RMK
			O-ring FKM DN80/100	20640-RMK
			Low-temperature O-ring, DN80/100	101341-RMK
4"	8.5	1	SB 55 circlip	19127

Nominal size	No. / Letter	Qty	Name	Part no.
4"	20	1	Standard O-ring	20752-RMK
			Low-temperature O-ring	101461
4"	21	1	O-ring NBR	20383
			O-ring FKM	20913
			Low-temperature O-ring	101462-RMK

Spare parts kits for actuator assembly with triggering unit - size of 2", 3", or 4"

Nominal size	No. / Letter	Qty	Name	Part no.
2"			2" 5020 R300 series spare parts kit (standard model) -NBR Class 150/300, PN 16/25/40	K5020-004
	5	1	Diaphragm, up to 50 bar DP	202/MJ/012
	10	1	O-ring NBR	730OAVN229
	23	1	Standard O-ring	20752-RMK
	64	1	O-ring NBR DN50	20246-RMK
	8.4	1	Vulcanized valve plate	10008606
	8.9	1	O-ring	20412
	8.2	1	O-ring NBR DN50	20596-RMK
	8.5	1	SB 55 circlip	19127
	20	1	Standard O-ring	20752-RMK
	21	1	O-ring NBR	20383

Nominal size	No. / Letter	Qty	Name	Part no.
2"			2" 5020 R300 series spare parts kit (low-temperature model) Class 150/300, PN 16/25/40	K5020-005
	5	1	Diaphragm, up to 50 bar DP	202/MJ/012
	10	1	Low-temperature O-ring	730ODVN229
	23	1	Low-temperature O-ring	101461
	64	1	Low-temperature O-ring, DN50	102063-RMK
	8.4	1	Vulcanized valve plate	18355630
	8.9	1	O-ring	101469-RMK
	8.2	1	Low-temperature O-ring, DN50	101566-RMK
	8.5	1	SB 55 circlip	19127
	20	1	Low-temperature O-ring	101461

Nominal size	No. / Letter	Qty	Name	Part no.
	21	1	Low-temperature O-ring	101462-RMK

Nominal size	No. / Letter	Qty	Name	Part no.
2"			2" 5020 R300 series spare parts kit (FKM/NBR model) Class 150/300, PN 16/25/40	K5020-006
	5	1	Diaphragm, up to 50 bar DP	202/MJ/012
	10	1	O-ring FKM	7300MVV229
	23	1	Standard O-ring	20752-RMK
	64	1	O-ring FKM DN50	20655-RMK
	8.4	1	Vulcanized valve plate	18356878
	8.9	1	O-ring	20914
	8.2	1	O-ring FKM DN50	20377
	8.5	1	SB 55 circlip	19127
	20	1	Standard O-ring	20752-RMK
	21	1	O-ring FKM	20913

Nominal size	No. / Letter	Qty	Name	Part no.
2"			2" 5020 R300 series spare parts kit (standard model) -NBR Class 600	K5020-007
	5	1	Diaphragm, up to 70 bar DP	202/MJ/013
	10	1	O-ring NBR	7300AVN229
	23	1	Standard O-ring	20752-RMK
	64	1	O-ring NBR DN50	20246-RMK
	8.4	1	Vulcanized valve plate	10008606
	8.9	1	O-ring	20412
	8.2	1	O-ring NBR DN50	20596-RMK
	8.5	1	SB 55 circlip	19127
	20	1	Standard O-ring	20752-RMK
	21	1	O-ring NBR	20383

Nominal size	No. / Letter	Qty	Name	Part no.
2"			2" 5020 R300 series spare parts kit (low-temperature model) Class 600	K5020-008
	5	1	Diaphragm, up to 70 bar DP	202/MJ/013
	10	1	Low-temperature O-ring	7300DVN229

Nominal size	No. / Letter	Qty	Name	Part no.
	23	1	Low-temperature O-ring	101461
	64	1	Low-temperature O-ring, DN50	102063-RMK
	8.4	1	Vulcanized valve plate	18355630
	8.9		O-ring	101469-RMK
	8.2	1	Low-temperature O-ring, DN50	101566-RMK
	8.5	1	SB 55 circlip	19127
	20	1	Low-temperature O-ring	101461
	21	1	Low-temperature O-ring	101462-RMK

Nominal size	No. / Letter	Qty	Name	Part no.
2"			2" 5020 R300 series spare parts kit (FKM/NBR model) Class 600	K5020-009
	5	1	Diaphragm, up to 70 bar DP	202/MJ/013
	10	1	O-ring FKM	7300MVV229
	23	1	Standard O-ring	20752-RMK
	64	1	O-ring FKM DN50	20655-RMK
	8.4	1	Vulcanized valve plate	18356878
	8.9	1	O-ring	20914
	8.2	1	O-ring FKM DN50	20377
	8.5	1	SB 55 circlip	19127
	20	1	Standard O-ring	20752-RMK
	21	1	O-ring FKM	20913

Nominal size	No. / Letter	Qty	Name	Part no.
3"			3" 5020 R300 series spare parts kit (standard model) -NBR Class 150/300, PN 16/25/40	K5020-010
	5	1	Diaphragm, up to 50 bar DP	203/MJ/013
	10	1	O-ring NBR	7300AVN238
	23	1	Standard O-ring	20752-RMK
	64	1	O-ring NBR DN80/100	20427
	8.4	1	Vulcanized valve plate	10008606
	8.9	1	O-ring	20412
	8.2	1	O-ring NBR DN80/100	20268-RMK
	8.5	1	SB 55 circlip	19127
	20	1	Standard O-ring	20752-RMK

	21	1	O-ring NBR	20383
--	----	---	------------	-------

Nominal size	No. / Letter	Qty	Name	Part no.
3"			3" 5020 R300 series spare parts kit (low-temperature model) Class 150/300, PN 16/25/40	K5020-011
	5	1	Diaphragm, up to 50 bar DP	203/MJ/013
	10	1	Low-temperature O-ring	730ODVN238
	23	1	Low-temperature O-ring	101461
	64	1	Low-temperature O-ring	101460-RMK
	8.4	1	Vulcanized valve plate	18355630
	8.9	1	O-ring	101469-RMK
	8.2	1	Low-temperature O-ring	101341-RMK
	8.5	1	SB 55 circlip	19127
	20	1	Low-temperature O-ring	101461
	21	1	Low-temperature O-ring	101462-RMK

Nominal size	No. / Letter	Qty	Name	Part no.
3"			3" 5020 R300 series spare parts kit (FKM/NBR model) Class 150/300, PN 16/25/40	K5020-012
	5	1	Diaphragm, up to 50 bar DP	203/MJ/013
	10	1	O-ring FKM	730OMVV238
	23	1	Standard O-ring	20752-RMK
	64	1	O-ring FKM DN80/100	20910-RMK
	8.4	1	Vulcanized valve plate	18356878
	8.9	1	O-ring	20914
	8.2	1	O-ring FKM DN80/100	20640-RMK
	8.5	1	SB 55 circlip	19127
	20	1	Standard O-ring	20752-RMK
	21	1	O-ring FKM	20913

Nominal size	No. / Letter	Qty	Name	Part no.
3"			3" 5020 R300 series spare parts kit (standard model) -NBR Class 600	K5020-013
	5	1	Diaphragm, up to 70 bar DP	203/MJ/014
	10	1	O-ring NBR	730OAVN238
	23	1	Standard O-ring	20752-RMK

64	1	O-ring NBR DN80/100	20427
8.4	1	Vulcanized valve plate	10008606
8.9	1	O-ring	20412
8.2	1	O-ring NBR DN80/100	20268-RMK
8.5	1	SB 55 circlip	19127
20	1	Standard O-ring	20752-RMK
21	1	O-ring NBR	20383

Nominal size	No. / Letter	Qty	Name	Part no.
3"			3" 5020 R300 series spare parts kit (low-temperature model) Class 600	K5020-014
	5	1	Diaphragm, up to 70 bar DP	203/MJ/014
	10	1	Low-temperature O-ring	730ODVN238
	23	1	Low-temperature O-ring	101461
	64	1	Low-temperature O-ring	101460-RMK
	8.4	1	Vulcanized valve plate	18355630
	8.9	1	O-ring	101469-RMK
	8.2	1	Low-temperature O-ring	101341-RMK
	8.5	1	SB 55 circlip	19127
	20	1	Low-temperature O-ring	101461
	21	1	Low-temperature O-ring	101462-RMK

Nominal size	No. / Letter	Qty	Name	Part no.
3"			3" 5020 R300 series spare parts kit (FKM/NBR model) Class 600	K5020-015
	5	1	Diaphragm, up to 70 bar DP	203/MJ/014
	10	1	O-ring FKM	730OMVV238
	23	1	Standard O-ring	20752-RMK
	64	1	O-ring FKM DN80/100	20910-RMK
	8.4	1	Vulcanized valve plate	18356878
	8.9	1	O-ring	20914
	8.2	1	O-ring FKM DN80/100	20640-RMK
	8.5	1	SB 55 circlip	19127
	20	1	Standard O-ring	20752-RMK
	21	1	O-ring FKM	20913

Nominal size	No. / Letter	Qty	Name	Part no.
4"			4" 5020 R300 series spare parts kit (standard model) -NBR Class 150/300, PN 16/25/40	K5020-016
	5	1	Diaphragm, up to 50 bar DP	204/MJ/003
	10	1	O-ring NBR	730OAVN244
	23	1	Standard O-ring	20752-RMK
	64	1	O-ring NBR DN80/100	20427
	8.4	1	Vulcanized valve plate	10008606
	8.9	1	O-ring	20412
	8.2	1	O-ring NBR DN80/100	20268-RMK
	8.5	1	SB 55 circlip	19127
	20	1	Standard O-ring	20752-RMK
	21	1	O-ring NBR	20383

Nominal size	No. / Letter	Qty	Name	Part no.
4"			4" 5020 R300 series spare parts kit (low-temperature model) Class 150/300, PN 16/25/40	K5020-017
	5	1	Diaphragm, up to 50 bar DP	204/MJ/003
	10	1	Low-temperature O-ring	730ODVN244
	23	1	Low-temperature O-ring	101461
	64	1	Low-temperature O-ring	101460-RMK
	8.4	1	Vulcanized valve plate	18355630
	8.9	1	O-ring	101469-RMK
	8.2	1	Low-temperature O-ring	101341-RMK
	8.5	1	SB 55 circlip	19127
	20	1	Low-temperature O-ring	101461
	21	1	Low-temperature O-ring	101462-RMK

Nominal size	No. / Letter	Qty	Name	Part no.
4"			4" 5020 R300 series spare parts kit (FKM/NBR model) Class 150/300, PN 16/25/40	K5020-018
	5	1	Diaphragm, up to 50 bar DP	204/MJ/003
	10	1	O-ring FKM	730OMVV244
	23	1	Standard O-ring	20752-RMK
	64	1	O-ring FKM DN80/100	20910-RMK

8.4	1	Vulcanized valve plate	18356878
8.9	1	O-ring	20914
8.2	1	O-ring FKM DN80/100	20640-RMK
8.5	1	SB 55 circlip	19127
20	1	Standard O-ring	20752-RMK
21	1	O-ring FKM	20913

Nominal size	No. / Letter	Qty	Name	Part no.
4"			4" 5020 R300 series spare parts kit (standard model) -NBR Class 600	K5020-019
	5	1	Diaphragm, up to 70 bar DP	204/MJ/004
	10	1	O-ring NBR	7300AVN244
	23	1	Standard O-ring	20752-RMK
	64	1	O-ring NBR DN80/100	20427
	8.4	1	Vulcanized valve plate	10008606
	8.9	1	O-ring	20412
	8.2	1	O-ring NBR DN80/100	20268-RMK
	8.5	1	SB 55 circlip	19127
	20	1	Standard O-ring	20752-RMK
	21	1	O-ring NBR	20383

Nominal size	No. / Letter	Qty	Name	Part no.
4"			4" 5020 R300 series spare parts kit (low-temperature model) Class 600	K5020-020
	5	1	Diaphragm, up to 70 bar DP	204/MJ/004
	10	1	Low-temperature O-ring	730ODVN244
	23	1	Low-temperature O-ring	101461
	64	1	Low-temperature O-ring	101460-RMK
	8.4	1	Vulcanized valve plate	18355630
	8.9	1	O-ring	101469-RMK
	8.2	1	Low-temperature O-ring	101341-RMK
	8.5	1	SB 55 circlip	19127
	20	1	Low-temperature O-ring	101461
	21	1	Low-temperature O-ring	101462-RMK

Nominal size	No. / Letter	Qty	Name	Part no.
4"			4" 5020 R300 series spare parts kit (FKM/NBR model) Class 600	K5020-021
	5	1	Diaphragm, up to 70 bar DP	204/MJ/004
	10	1	O-ring FKM	730OMVV244
	23	1	Standard O-ring	20752-RMK
	64	1	O-ring FKM DN80/100	20910-RMK
	8.1	1	Pre-assembled valve shank, DN80/100	10032455
	8.4	1	Vulcanized valve plate	18356878
	8.9	1	O-ring	20914
	8.5	1	SB 55 circlip	19127
	20	1	Standard O-ring	20752-RMK
	21	1	O-ring FKM	20913

9.4 Spare parts for actuator assembly with triggering unit - 6" size

Spare parts drawing for actuator assembly with triggering unit - 6" size

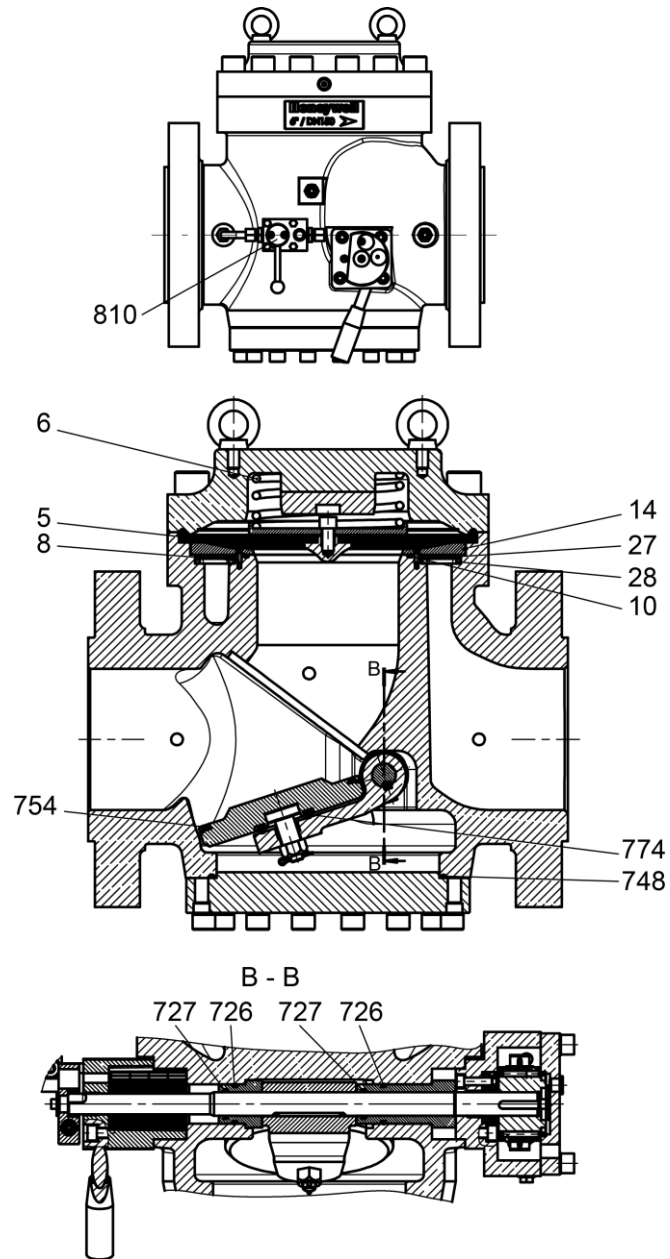

Maintenance and servicing parts for actuator assembly with triggering unit - 6" size

Nominal size	No. / Letter	Qty	Name	Part no.
6"	5	1	Diaphragm 50/70 bar DP	10011307
6"	10	1		
			O-ring NBR	730ODVN261
			Low-temperature O-ring	730ODVN261
			O-ring FKM	730OMVV261
6"	6	1	Closing spring	10011249
6"	8	6	Screws	710BCFE03010
6"	14	1		
			Flow restrictor, 100%	206/MZ/002
			Flow restrictor, 75%	206/MZ/010
			Flow restrictor, 50%	206/MZ/006
			Flow restrictor 25%	206/MZ/011
6"	27	1	Carrier plate	206/MN/001
6"	28	1	Metal foam	206/MF/001
6"	726	2		
			O-ring NBR	20336
			Low-temperature O-ring	100967-RMK
			O-ring FKM	20599
6"	727	2		
			O-ring NBR	20251-RMK
			Low-temperature O-ring	101036-RMK
			O-ring FKM	20600-RMK
6"	748	1		
			O-ring NBR	21193
			Low-temperature O-ring	101037-RMK
			O-ring FKM	21223-RMK
6"	754	1		
			O-ring NBR	20338
			Low-temperature O-ring	101035-RMK
			O-ring FKM	20610
6"	774	1	O-ring	100399-RMK
6"	810	1	HON 910 push-button valve	89100210

Spare parts kits for actuator assembly with triggering unit - 6" size

Nominal size	No. / Letter	Qty	Name	Part no.
6"			6" 5020 R300 series spare parts kit (standard model) -NBR Class 300/600	K5020-022
	5	1	Diaphragm 50/70 bar DP	10011307
	10	1	O-ring NBR	730ODVN261
	726	2	O-ring NBR	20336
	727	2	O-ring NBR	20251-RMK
	748	1	O-ring NBR	21193
	754	1	O-ring NBR	20338
	774	1	O-ring NBR	100399-RMK

Nominal size	No. / Letter	Qty	Name	Part no.
6"			6" 5020 R300 series spare parts kit (low-temperature model) Class 300/600	K5020-023
	5	1	Diaphragm 50/70 bar DP	10011307
	10	1	Low-temperature O-ring	730ODVN261
	726	2	Low-temperature O-ring	100967-RMK
	727	2	Low-temperature O-ring	101036-RMK
	748	1	Low-temperature O-ring	101037-RMK
	754	1	Low-temperature O-ring	101035-RMK
	774	1	Low-temperature O-ring	100399-RMK

Nominal size	No. / Letter	Qty	Name	Part no.
6"			6" 5020 R300 series spare parts kit (FKM/NBR model) Class 300/600	K5020-024
	5	1	Diaphragm 50/70 bar DP	10011307
	10	1	O-ring FKM	730OMVV261
	726	2	O-ring FKM	20599
	727	2	O-ring FKM	20600-RMK
	748	1	O-ring FKM	21223-RMK
	754	1	O-ring FKM	20610
	774	1	O-ring FKM	100399-RMK

9.5 Spare parts for HON 910 push-button valve for actuator assembly with 6" size

Spare parts drawing for HON 910 push-button valve

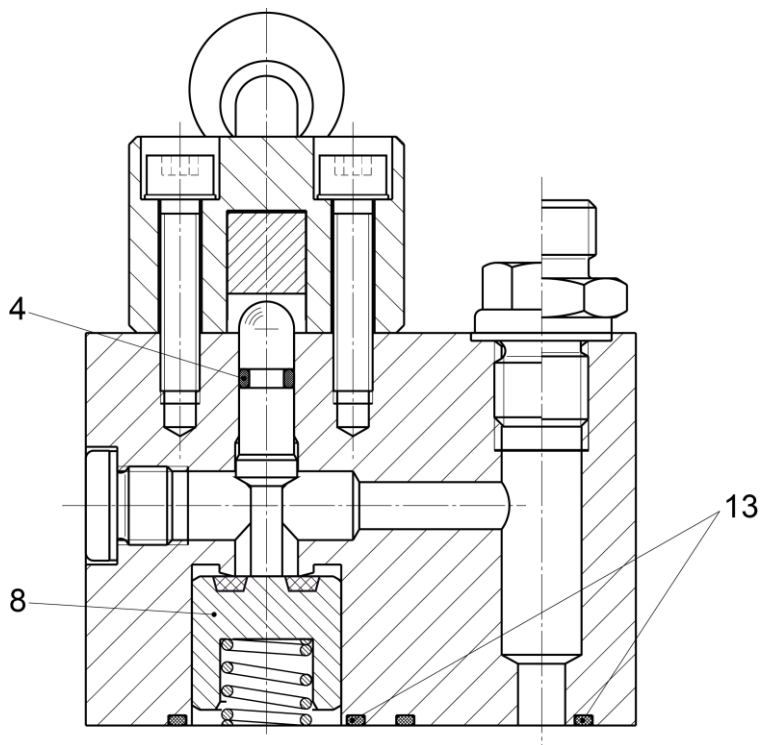

Maintenance parts for HON 910 push-button valve

No. / Letter	Qty	Name	Part no.
4	1	O-ring NBR	20309
		O-ring FKM	20794-RMK
8	1	Piston	10022595
13	2	O-ring FKM	20926-RMK
		O-ring NBR	20232-RMK

9.6 Spare parts for travel indication option

Spare part drawings

Optical travel indicator

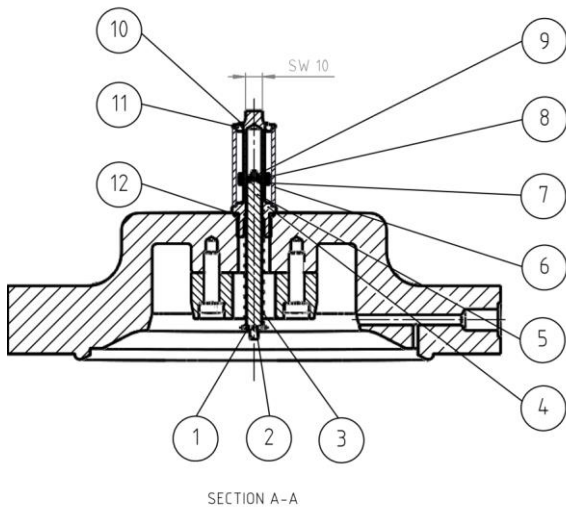

Optical travel indicator with remote control

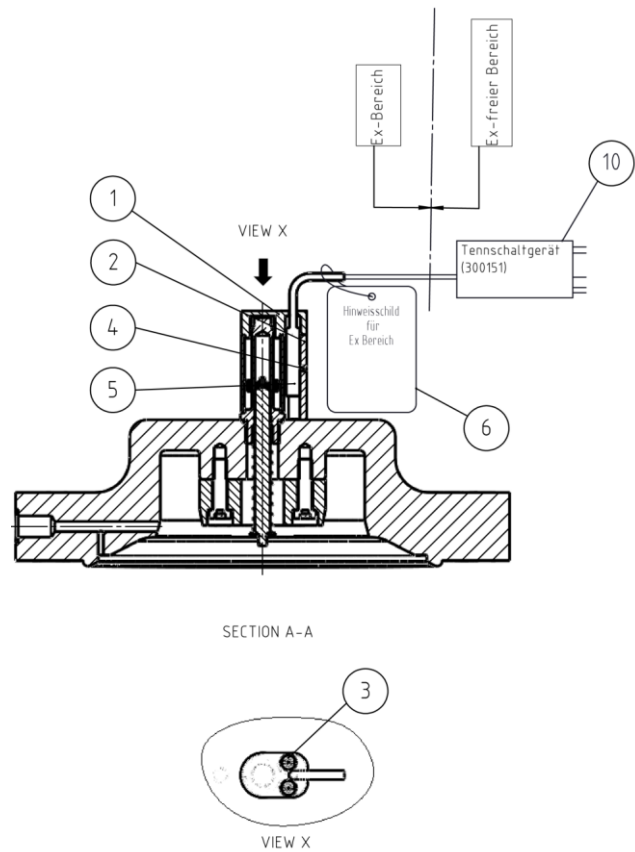

Maintenance and serving parts

No.	Qty	Name	NBR Part-no.	FKM Part-no.
12	1	O-Ring	100448-RMK	20823

9.7 Lubricants

Lubricants

Important! All parts must be slightly greased.

Use the following lubricants:

Application	Remark	Lubricant	Part no.
O-rings Stationary and moving		Standard model:	
Flat gaskets		Silicone grease (jar)	27079
Diaphragms	Grease the diaphragm grip body on all sides Do NOT grease the flat grip	Silicone grease (tube)	27081
Valve shank sliding surfaces		Low-temperature model:	
Sliding guides		Silicone grease (jar)	27993
Guide bushings			
Moving parts in SAV controlgear and switchgear	Grease film only	High-temperature model:	
Switch jacks and locking sleeves		PFPE grease	102389
Control balls and control rollers			
Ball bearing			
Valve sleeves and valve sleeve gaskets in gas pressure regulators		Silicone grease	27052
Setpoint set screws Power screws			
Thread material combination: Al/Al		Assembly paste	27091
Screw-in fittings and fastening screws			
Spring plate depressions (pilot)			
Devices for oxygen Important! Oil-free and grease-free installation; only antiseize agents are permissible	Upper oxygen pressure limit: 260 bar at 60 °C	Antiseize agent	28211
Devices for ammonia		Antiseize agent	28211

Subject to change without notice



Scan these QR Codes to see how Honeywell's integrated gas solutions can help you to better manage your gas assets and optimize your value chain.

Additional information

To learn more about Honeywell's product contact your Honeywell Process Solutions representative, or visit www.honeywellprocess.com or www.hongastec.de.

Honeywell Process Solutions

1250 West Sam Houston Parkway South
Houston, TX 77042
Phone: 1-602-293-1866 Option 4

Honeywell Gas Technologies GmbH
Osterholzstrasse 45
34123 Kassel, Germany
Phone: +49 (0) 561 5007111

Emaar Business Park, Building 2, Sheikh Zayed
Road, PO Box 232362
Dubai, United Arab Emirates
Phone: +97144505800

Honeywell Engineering Sdn Bhd
1st Floor, Block B, No.10
Jalan Bersaru 13/4
46200, Petaling Jaya Selangor DE, Malaysia
Phone: +603 7626 57000

A1 Building, C&W Industry Zone
No.14, Jiuxiangqiao Rd., Chaoyang District,
Beijing, P.R. China 100015
Phone: +8610-56696001

www.honeywellprocess.com
www.hongastec.de

June 2021 – REV C
© 2021 Honeywell International Inc.

Honeywell