

HON 901

Pneumatic Gas Pre-Heater with On/off- Valve

Operating and Maintenance
Instructions/Spare Part

Contents

Page

1.	General Information	3
1.1	Safety information	3
2.	Specific maintenance instructions	4
2.1	Tightening torques	4
2.2	Lubricants	4
2.3	Threadlocking adhesives	4
	Installation situation of the pneum.	
3.	Gas Preheater HON 901 in Gas Pressure Regulators	5
3.1	for Actuators in conventional design	5
3.2	for Actuators with throttle diaphragm	5
4.	Spare parts	
4.1.1	Spare parts drawing HON 901	6
4.1.2	Spare parts list HON 901	7
4.2.1	Spare parts drawing Accessory and Control valve	8
4.2.2	Spare parts list Accessory and Control valve	9
4.3	Parts for maintenance purposes	10

1. General Information

All persons involved with the assembly, operation and/or maintenance of gas pressure regulators must read and understand all of the following documents:

- Technical product information (brochure *.00) - it contains the technical data and dimensions of the equipment as well as instructions concerning set-up and mode of operation.
- General operating manual for gas pressure regulators and safety devices - this Honeywell document contains information on assembly and operation as well as general information on troubleshooting.
- Operating and maintenance instructions / spare parts (brochure*.20) - this document contains more detailed information on assembly and operation of the gas pressure regulator.

There are national laws and regulations for all sorts of jobs on gas pressure regulators, from planning to maintenance. Be sure to comply. (In Germany, for instance, DVGW work sheets G 600, G 459/II, G 491 and G 495.)

Inspection and maintenance intervals depend mostly on operating conditions and the nature and properties of the gas. There are no general rules or recommendations for intervals. For Germany, we recommend to consider maintenance intervals as stated in DVGW work sheet G 495 in a first instance. However, in the mid-term, intervals must be adapted to the requirements of each specific equipment.

During maintenance, components must be cleaned and then checked thoroughly. This is necessary even if there have been any unusual observations during operation and/or functional testing. Checks must focus, in particular, on diaphragms and seals and all movable parts and their respective bearings. Any and all defective parts must be replaced with new ones. The same applies to O rings removed during disassembly.



It is not permitted to use spare parts or lubricants other than those expressly specified in this document Honeywell Operating and Maintenance Manual for spare parts.

In the event if other than the expressly listed spare parts and lubricants are used, Honeywell not liable for any defects or consequential damages resulting from the use of unauthorized replacement parts or lubricants arise. Item numbers mentioned in the specific operating and maintenance instructions correspond with the numbers in the spare parts lists and drawings.

Some parts in the lists and drawings are marked with a letter **"W"**. We recommend you always have a reserve of those parts in stock for maintenance purposes. Those spare parts are put together in another separate list at the end of the spare parts list.

1.1 Safety information

In this manual, safety information is highlighted by means of the following titles and eye catchers:

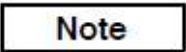
Eye catchers	used for:
	Danger to life and limb
	Danger of damage to property and/or the environment
	Important additional information

2. Specific maintenance instruction

- Diaphragm (73)

During assembly, make sure that the diaphragm is in the correct position.

- Diaphragm plate (51)

When tightening the valve sleeve (60) and hex nut (71), the diaphragm plate is equipped with a Secure key SW 24 against twisting.

2.1 Tightening torques M_A

Item.no.	Tightening torque M_A in Nm
24, 63	15
60, 71	20
16, 66	25

2.2 Lubricants

Components (grease lightly)	Lubricants	HON-part-no..
all O-Rings, Sliding guide, Sliding surface and Switching element	Silicone grease	27081 (tube 0,1 kg)
All fastening screws and screwed pipe connections	Assembly paste	27058

2.3 Threadlocking adhesives

Components (grease lightly)	Safeguards	HON-part-no..
Thread of the hex nut (71) Thread of the valve sleeve (60)	LOCTITE	26688 (tube 0,1 kg)
Set screws (14)	LOCTITE	27231

3. Installation situation of the pneum. Gas Preheater HON 901 in Gas Pressure Regulators
 3.2 for Actuators in conventional design

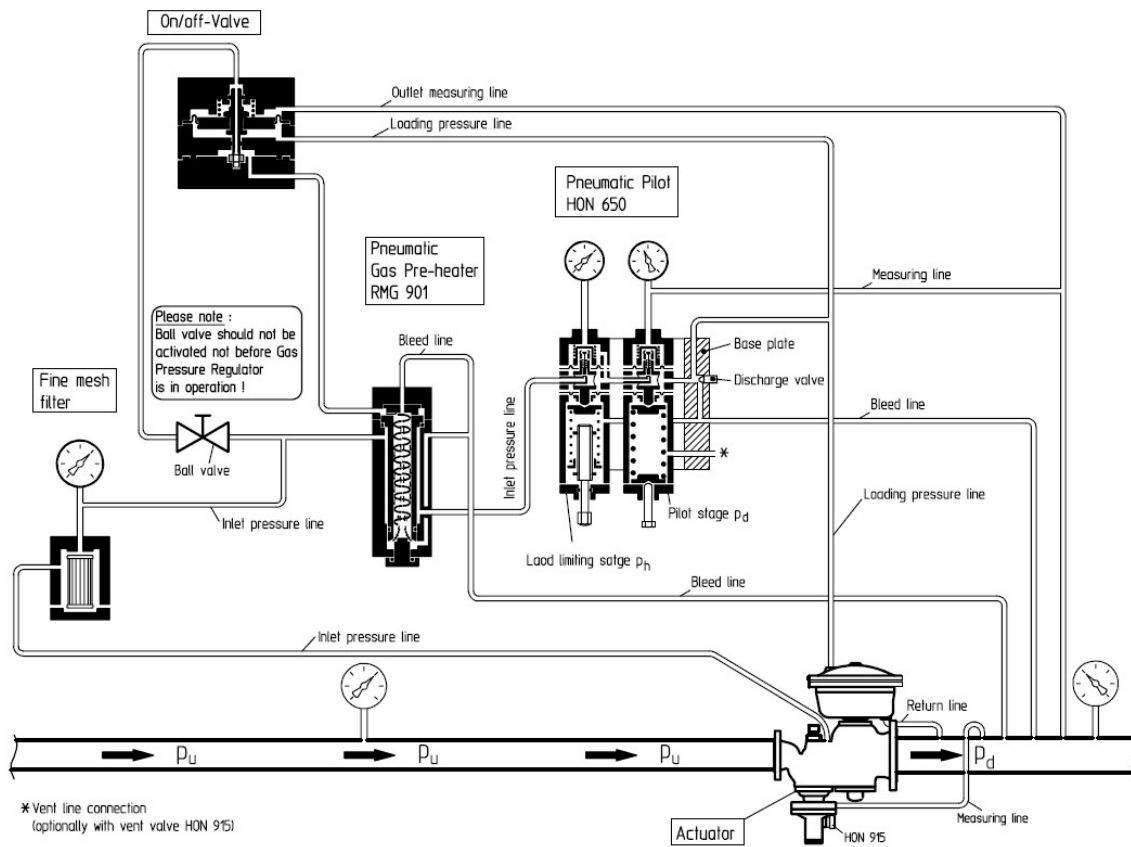

3.2 for Actuators with throttle diaphragm

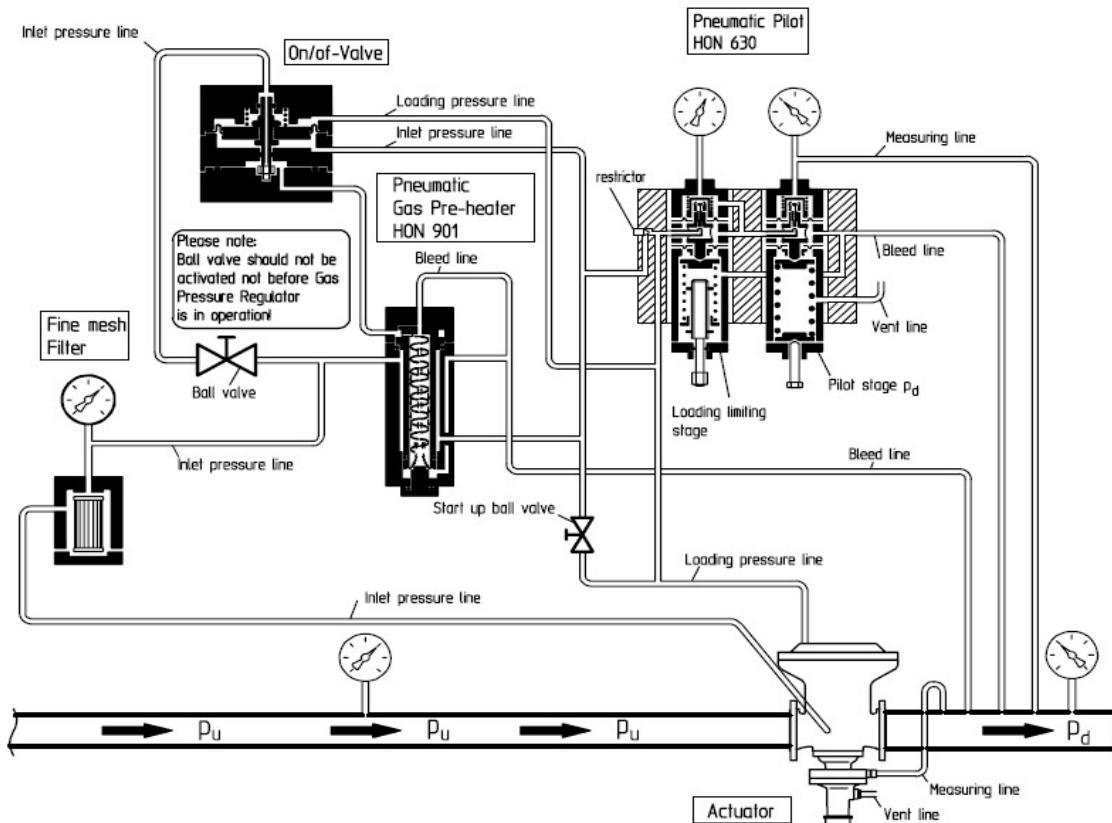

4. Spare parts
 4.1.1 Spare parts drawing HON 901

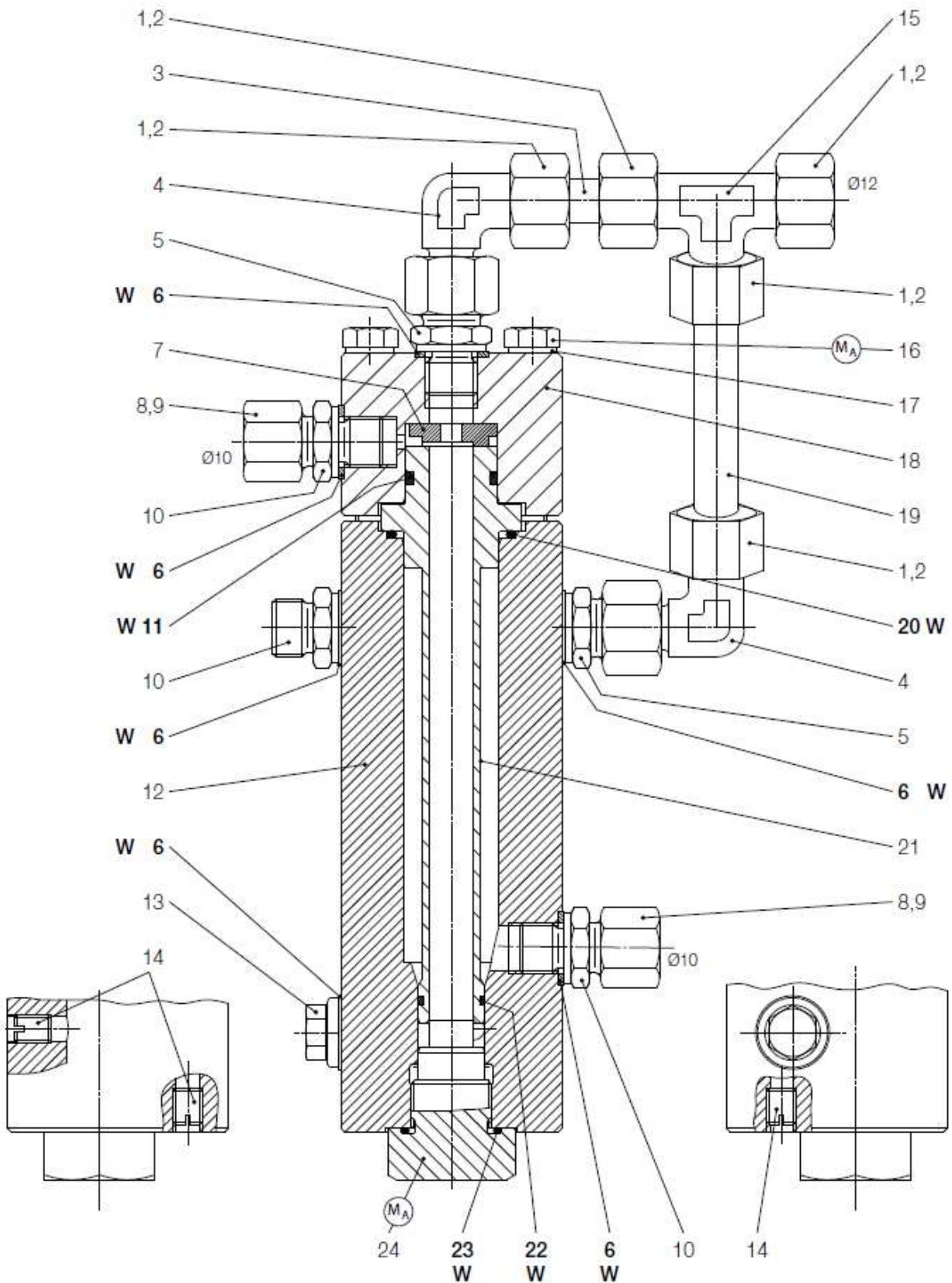

MA Be sure to comply with tightening torques in table on page 4.

W Parts should be held in stock for maintenance purposes stock for maintenance purposes

4.1.2 Spare parts list HON 901

Item no.	Description	Number	W	Material	Part-no.
1	Union nut	5		St	30804-RMK
2	Cutting ring	5		St	30904
3	Pipe section	1		St	32117
4	Connection pipe (DIN 2353/ISO 8434-1)	2		St	31213
5	Connection pipe (DIN 2353/ISO 8434-1)	2		St	30074
6	Sealing ring	6	W	LM	18842-RMK
7	Injection nozzle	1		LM	10030065
8	Union nut	2		St	30803-RMK
9	Cutting ring	2		St	30903
10	Connection pipe (DIN 2353/ISO 8434-1)	3		St	30111-RMK
11	O-Ring	1	W	KG	20383
12	Body	1		LM	10030064
13	Plug screw	1		St	26175
14	Set screw	3		Ms	10010496
15	Connection pipe (DIN 2353/ISO 8434-1)	1		St	31433
16	Sechskantschraube	4		St	10043
17	Washer	4		St	14156
18	Cover	1		LM	10030281
19	pipe 90 mm long	1		St	35507
20	O-Ring	1	W	KG	20237-RMK
21	Cyclone tube	1		LM	10030066
22	O-Ring	1	W	KG	20333
23	O-Ring	1	W	KG	20342
24	Adjusting valve	1		LM	10030067

W Parts should be held in stock for maintenance purposes

German abbreviations stand for the following materials:

St ... steel	LM ... light metal / alloy	GMs ... cast brass
NSt ... stainless steel	Ms ... brass	GZn ... cast zinc
FSt ... spring steel	GS ... cast steel	AlBz ... aluminium bronze
NFSt ... stainless spring steel	GGG ... spheroidal graphite cast iron	K ... synthetic materials
Bz ... bronze	GBz ... cast bronze	KG ... gummosus synthetic materials
Cu ... copper	GLM ... cast light metal	SSt ... foamed materials

4.2.1 Spare parts drawing Accessory and Control valve

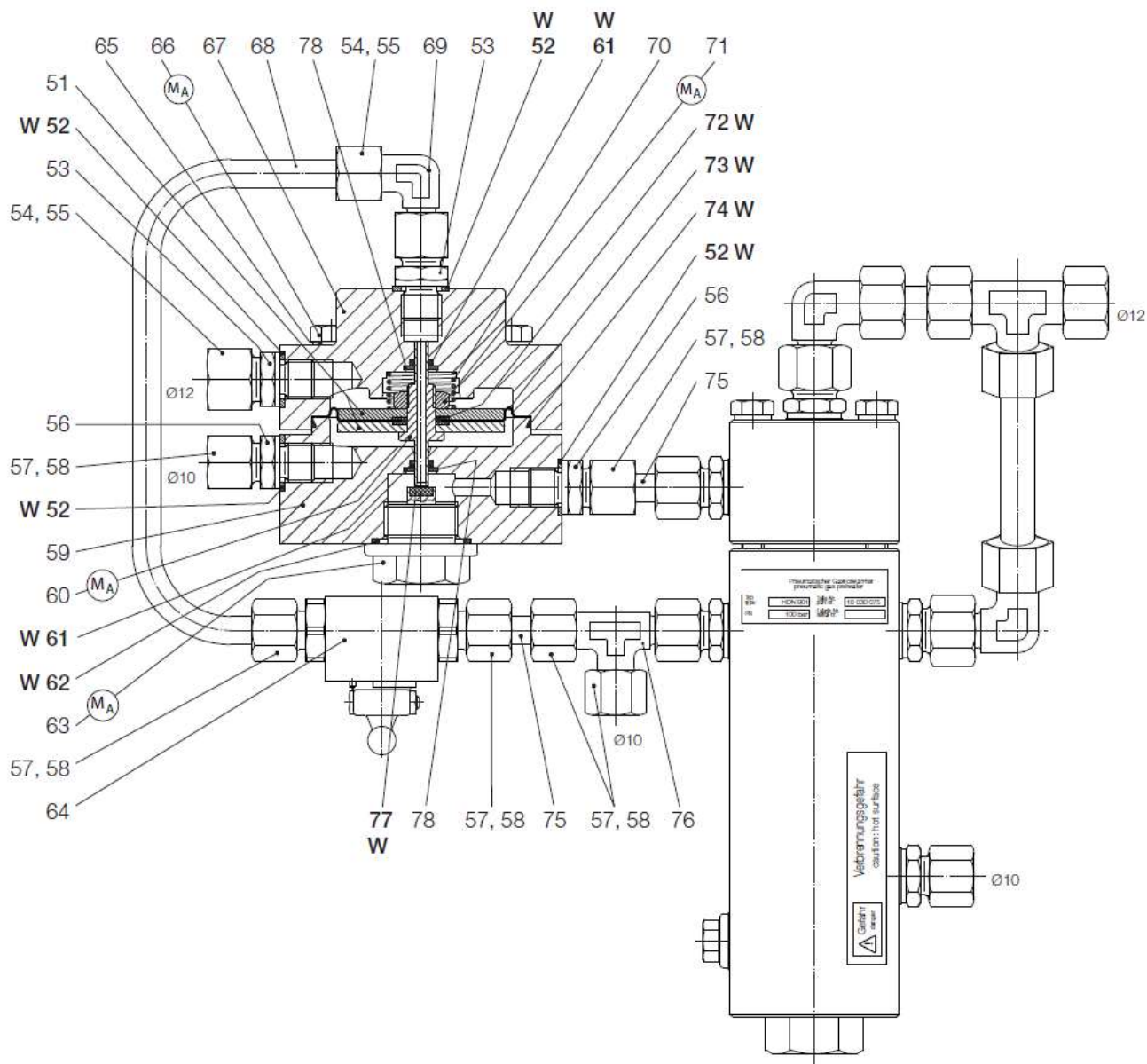

MA Be sure to comply with tightening torques in table on page 4.

W Parts should be held in stock for maintenance purposes stock for maintenance purposes

4.2.2 Spare parts list Accessory and Control valve

Item no.	Description	Number.	W	Material	HON-Part-No.
51	Diaphragm plate	2		LM	10030074
52	Sealing ring	4	W	LM	18842-RMK
53	Connection pipe (DIN 2353/ISO 8434-1)	2		St	30074
54	Union nut	2		St	30804-RMK
55	Cutting ring	2		St	30904
56	Connection pipe (DIN 2353/ISO 8434-1)	2		St	30111-RMK
57	Union nut	6		St	30803-RMK
58	Cutting ring	6		St	30903
59	Diaphragm housing , complete	1		LM/Ni/KG	10030695
60	Valve sleeve	1		Ni	10030073
61	O-Ring	2	W	KG	20345
62	O-Ring	1	W	KG	20237-RMK
63	Closure piston	1		Ni	10030280
64	Stopcock	1		St	26457-RMK
65	Washer	4		St	14153
66	Hexagon srcew	4		St	10011
67	Diaphragm cover, complete	1		LM/Ni/KG	10030696
68	pipe ø10, 280 mm long	1		St	35505
69	Connection pipe (DIN 2353/ISO 8434-1)	1		St	31207
70	Control spring	1		NSt/Ms	10010463
71	Hex nut	1		St	13114
72	Stem seal	1	W	KG	10000066
73	Diaphragm	1	W	KG	10030376
74	O-Ring	1	W	KG	100212
75	Pipe piece	2		St	32101
76	Connection pipe (DIN 2353/ISO 8434-1)	1		St	30622
77	Sealing ring	1	W	KG	10014474
78	Washer	2		NSt	10030694

4.3 Parts for maintenance purposes

Item no.	Description			Numer	HON-Part-no.
6	Sealing ring			6	18842-RMK
11	O-Ring			1	20383
20	O-Ring			1	20237-RMK
22	O-Ring			1	20333
23	O-Ring			1	20342
52	Sealing ring			4	18842-RMK
62	O-Ring			1	20237-RMK
72	Stem seal			1	10000066
73	Diaphragm			1	10030376
74	O-Ring			1	100212
77	Sealing ring			1	10014474

Honeywell Process Solutions

1250 West Sam Houston Parkway
South
Houston, TX 77042
Phone: 1-602-293-1866 Option 4

Osterholzstrasse 45
23123 Kassel, Germany
Phone: +49 (0) 561 5007000

Emaar Business Park, Building 2,
Sheikh Zayed Road, PO Box 232362
Dubai, United Arab Emirates
Phone: +97144505800

Honeywell Engineering Sdn Bhd
1st Floor, Block B, No.10
J a lan Bersaru 13/4
46200, Petaling Jaya Selangor DE,
Malaysia
Phone+603 7626 57000

A1 Building, C&W Industry Zone
No.14, Jiuxiangqiao Rd., Chaoyang
District, Beijing, P.R.China 100015
Phone: +8610-56696001

www.honeywellprocess.com
www.hongastec.de

370.20 S.50

Dezember 2019
© 2017 Honeywell International Inc.

The Honeywell logo is displayed in a bold, red, sans-serif font.