

OPERATING AND MAINTENANCE INSTRUCTIONS/
SPARE PARTS

EDITION 01/2017

**Serving the Gas Industry
Worldwide**

Honeywell

Contents		Page
1.	General information	3
1.1	Safety information	3
2.	Specific operating instructions	4
2.1	Changing setpoints	4
3.	Specific maintenance instructions	4
3.1	Tightening torques	4
3.2	Lubricants	4
4.	Spare parts	
4.1.1	Spare parts drawing - type with measuring unit M	5
4.1.1.1	Spare parts drawing - section views	6
4.1.2	Spare parts list - type with measuring unit M	7, 8
4.2.1	Spare parts drawing - type with measuring unit F	9
4.2.2	Spare parts list - type with measuring unit F	10, 11
4.3.1	Spare parts drawing - type with measuring unit V	12
4.3.2	Spare parts list - type with measuring unit V	13, 14
4.4.1	Spare parts drawing - type with measuring unit G	15
4.4.2	Spare parts list - type with measuring unit G	16, 17
4.5.1	Spare parts drawing - type with measuring unit GS	18
4.5.2	Spare parts list - type with measuring unit GS	19, 20
5.	Parts for maintenance purposes	21, 22

1. General information

All persons involved with the assembly, operation and/or maintenance of pressure reducer HON 219 must read and understand all of the following documents:

- Technical product information 219.00 - it contains the equipment's technical data and dimensions as well as instructions concerning set-up and mode of operation.
- General operating manual for gas pressure regulators and safety devices – this Honeywell document contains information on assembly and operation as well as general information on troubleshooting.
- Operating and maintenance instructions/spare parts 219.20 – this document contains more detailed information on assembly and operation of pressure reducer HON 219.

There are national laws and regulations for all sorts of jobs on gas pressure governors, from planning to maintenance. Be sure to comply. (In Germany, for instance, DVGW work sheets G 600, G 459/II, G 491 and G 495.)

Inspection and maintenance intervals depend mostly on operating conditions and the nature and properties of the gas. There are no general rules or recommendations for intervals. For Germany, we recommend to consider maintenance intervals as stated in DVGW work sheet G 495 in a first instance. However, in the mid-term, intervals must be adapted to the requirements of each specific equipment.

During maintenance, components must be cleaned and then checked thoroughly. This is necessary even if there have not been any unusual observations during operation and/or functional testing. Checks must focus,

in particular, on diaphragms and seals and all movable parts and their respective bearings. Any and all defective parts must be replaced with new ones. The same applies to O rings removed during disassembly. Do not use any spare/wear parts and/or oils & lubricants not specifically recommended in the Honeywell operating and maintenance instructions for spare parts.



In the event spare/wear parts and/or lubricants & oils other than those specifically recommended are used, Honeywell shall not be liable for any defects and/or consecutive damages attributable to such use of illegal parts, lubricants, oils etc.

Item numbers mentioned in the specific operating and maintenance instructions correspond with the numbers in the spare parts lists and drawings.

Some parts in the lists and drawings are marked with a letter "W". We recommend to always have a reserve of those parts in stock for maintenance purposes. Those spare parts are put together in another separate list at the end of the spare parts list.

1.1 Safety information

In this manual, safety information is highlighted by means of the following titles and eye catchers:

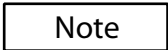
Eye catcher	used for:
	Danger to life and limb
	Danger of damage to property and/or the environment
	Important additional information

2. Specific operating instructions

2.1 Changing setpoints

- Increase the setpoint by turning the setpoint adjusting screw. Having changed the setpoint of the control stage, be sure to secure the setpoint adjuster using flat head screw (213, 313) or nut (3).

Note

Safety relief valve does not allow the setpoint to be changed.
 The following setpoints have been pre-set:
 – 5 bar approx. – for measuring units M, G, GS, F
 – 10 bar approx. – for measuring unit V

3. Specific maintenance instructions

- Be sure to adjust the connection between lever and lever eye to the central position. Find the central position by test-turning the diaphragm all the way to the stops on the left and on the right.

! Danger

- Replacing distance piece (23)

Do not dismount inlet connection piece (23, 59).

When installing the pressure reducer on a pipework system and when removing it, be sure to use an SW wrench to secure inlet connection piece (23, 59) and outlet connection piece (33) so they don't move and/or come loose.

When replacing jet connecting piece (23) and/or distance piece with jet and piston guide (28), be sure to observe proper piston mounting position.

See also "Mounting and dismounting sealing shim (29)".

- Mounting and dismounting sealing shim (29)

When dismounting piston and seal (29): Do not start to unscrew jet connecting piece (59) and/or distance piece with jet and piston guide (23, 27, 28) before you have dismounted cap (4) from body (18).

When mounting piston and seal (29): always mount together with jet connecting piece (59) and/or distance piece with jet and piston guide (23, 27, 28) while diaphragm (10) and cap (4) are still off. Be sure to find the correct mounting position of the piston inside the jet.

3.1 Tightening torques M_A in Nm

Screws & bolts – item no.	Tightening torques M_A in Nm
8, 208, 308	8

3.2 Lubricants

Components	Lubricants	HON part no.
All O rings Clamping area of the diaphragm Slip faces of pistons	Silicone grease Slip agent (ammonia)	27081 28211
Thread of setpoint adjusting screw/ adjusting spindle All fastening screws and screwed pipe connections	Assembly paste Slip agent (ammonia)	27091 28211

4.1.1 Spare parts drawing – type with measuring unit M
 Jet - Ø2, Ø3.7 and Ø5.5

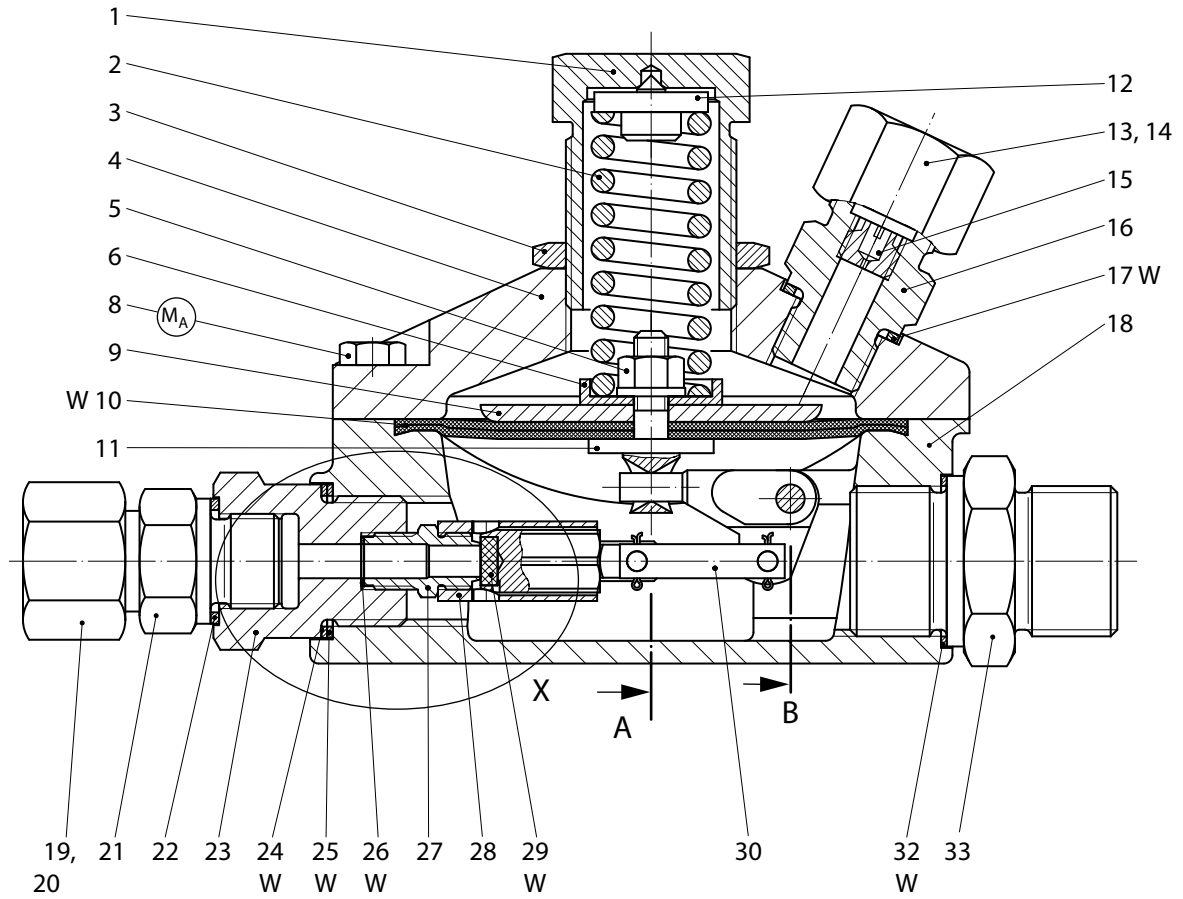

M_A Be sure to comply with tightening torques in table on page 4.

W Parts should be held in stock for maintenance purposes.

For section views see page 6.

4.1.1.1 Sections

Partial section A
Safety valve

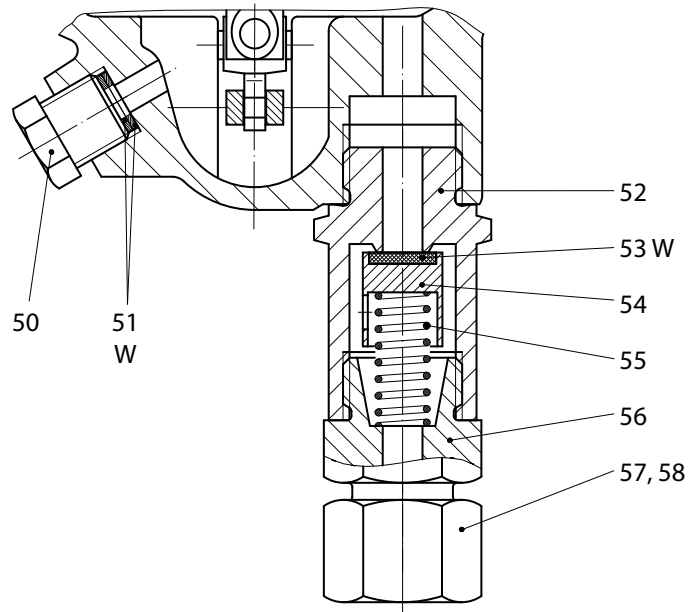

Detail "X"
Type with jet - Ø 8

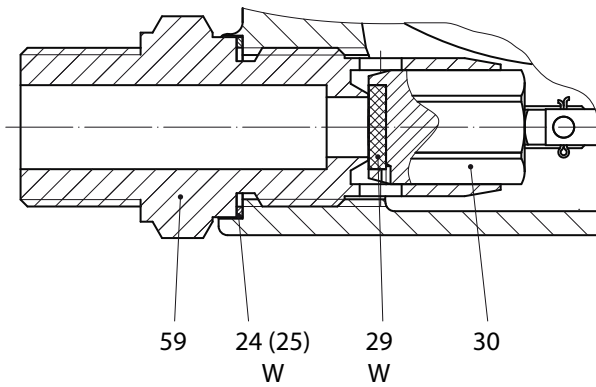

Partial section B

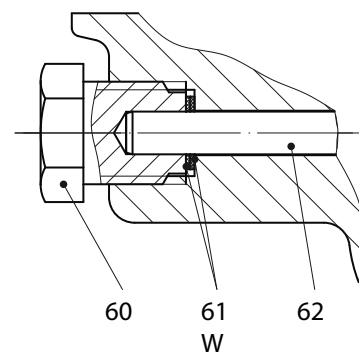

Detail "X"
Type with jet - Ø 10

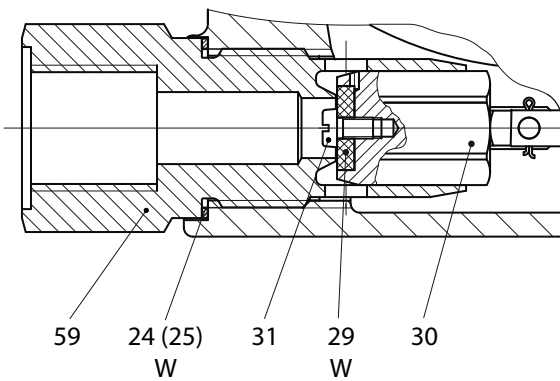

W Parts should be held in stock for maintenance purposes.

4.1.2 Spare parts list – type with measuring unit M

Item no.	Denomination	Number	W	Standard version		Ammonia version	
				Materials	Part no.	Materials	Part no.
1	Adjusting screw	1		Ms	10014999	NSt	10015001
2	Control spring, optional:						
2	Control spring F0 Ø 3.3 for Wds 0.1 to 1.5 bar (green)	1		FSt	10016654	FSt	10016654
2	Control spring F1 Ø 4 for Wds 0.2 to 2.5 bar (blue)	1		FSt	10016655	FSt	10016655
2	Control spring F2 Ø 4.5 for Wds 0.3 to 3.5 bar (brown)	1		FSt	10015005	FSt	10015005
3	Locknut	1		St	10014996	St	10014996
4	Cap	1		LM	10014988	LM	10014988
5	Hex collar nut	1		St/KG	13138	St/KG	13138
6	Spring guide plate	1		LM	10017697	LM	10017697
8	Hex screw	6		St	10116	St	10116
9	Diaphragm disc	1		St	10014983	St	10014983
10	Diaphragm (3 mm thick)	1	W	KG	10014989	KG	10018122
11	Lever eye	1		NSt	10014993	NSt	10014993
12	Compensation piece	1		St	10016656	St	10016656
13	Union nut	1		St	30805	St	30805
14	Cutting ring	1		St	30904	St	30904
15	Dosing screw	1		Ms	10005096	NSt	10005097
16	Connection pipe	1		St	10007639	St	10007639
17	Sealing ring	1	W	LM	18688	LM	18688
18	Body, optional:						
18	Housing for jet Ø 2 to Ø 8	1		GLM	10016694	GLM	10016694
18	Housing for jet Ø 10	1		GLM	10016695	GLM	10016695
19	Cap nut, optional:						
19	Cap nut for pipe Ø 10	1		St	30802	St	30802
19	Cap nut for pipe Ø 12	1		St	30805	St	30805
19	Cap nut for pipe Ø 16	1		St	30807	St	30807
20	Compression joint, optional:						
20	Compression joint for pipe Ø 10	1		St	30903	St	30903
20	Compression joint for pipe Ø 12	1		St	30904	St	30904
20	Compression joint for pipe Ø 16	1		St	30906	St	30906
21	Nozzle, optional:						
21	Nozzle for pipe Ø 10	1		St	30102	St	30102
21	Nozzle for pipe Ø 12	1		St	30104	St	30104
21	Nozzle for pipe Ø 16	1		St	30106	St	30106
22	Sealing ring, at option:						
22	Sealing ring for pipes Ø 10 and Ø 12	1		LM	18688	LM	18688
22	Sealing ring for pipe Ø 16	1		LM	18684	LM	18684
23	Distance piece, at option:						
23	Distance piece for pipes Ø 10 and Ø 12	1		Ms	10015071	NSt	10015073
23	Distance piece for pipe Ø 16	1		Ms	10015075	NSt	10015077
23	Distance piece for G 3/4 external	1		Ms	10016726	NSt	10016728

W Parts should be held in stock for maintenance purposes.

German abbreviations stand for the following materials:

St ... steel	LM ... light metal/alloy	GMs ... cast brass
NSt ... stainless steel	Ms ... brass	GZn ... cast zinc
FSt ... spring steel	GS ... cast steel	AlBz ... aluminium bronze
NFSt ... stainless spring steel	GGG ... spheroidal graphite cast iron	K ... synthetic materials
Bz ... bronze	GBz ... cast bronze	KG ... gummous synthetic materials
Cu ... copper	GLM ... cast light metal	P ... paper

Spare parts list – type with measuring unit M

Item no.	Denomination	Number	W	Standard version		Ammonia version	
				Materials	Part no.	Materials	Part no.
24	Sealing ring 1 mm	1	W	LM	18814	LM	18814
25	Sealing ring 1.5 mm	1	W	LM	18815	LM	18815
26	Sealing ring	1	W	LM	18811	LM	18811
27	Jet, at option:						
27	Jet Ø 2	1		Ms	10014458	NSt	10014460
27	Jet Ø 3.7	1		Ms	10014462	NSt	10014464
27	Jet Ø 5.5	1		Ms	10014466	NSt	10014468
28	Piston guide	1		Ms	10014470	NSt	10014471
29	Sealing shim, at option:						
29	Sealing shim for jet Ø 2, Ø 3.7, Ø 5.5	1	W	KG	10014473	KG	10014476
29	Sealing shim for jet Ø 8	1	W	KG	10014485	KG	10014487
29	Sealing shim for jet Ø 10	1	W	KG	10014495	KG	10015106
30	Joint, pre-assembled, optional:						
30	Joint, pre-assembled, for jet Ø 2, Ø 3.7, Ø 5.5	1		NSt/Ms	10014452	NSt	10014453
30	Joint, pre-assembled, for jet Ø 8	1		NSt/Ms	10014477	NSt	10014478
30	Joint, pre-assembled, for jet Ø 10	1		NSt/Ms	10014489	NSt	10014490
31	Round-head screw	1		Ms	8608	St	11126
32	Sealing ring	1	W	LM	4428	LM	4428
33	Distance piece for G 3/4 external	1		Ms	10016757	NSt	10016758
50	Plug G 1/4	1		Ms	10016698	NSt	10016699
51	Sealing ring	2	W	LM	18818	LM	18818
Safety valve for response pressure up to 5 bar, choose from items 52 - 58:		1			10019427		10019431
52	Safety valve body		1		LM	10014073	LM
53	Sealing shim	1	W	KG	10014082	KG	10014085
54	Valve cone	1		Ms	10014078	NSt	10014079
55	Control spring Ø 1.2	1		NFSt	10014077	NFSt	10014077
56	Distance piece	1		St	10015036	St	10015036
57	Union nut	1		St	30805	St	30805
58	Cutting ring	1		St	30904	St	30904
59	Jet connecting piece, at option:						
59	Jet connecting piece G 3/4a, jet Ø 8	1		Ms	10015094	NSt	10015096
59	Jet connecting piece G 1/2 internal, jet Ø 8	1		Ms	10015090	NSt	10015093
59	Jet connecting piece G 3/4a, jet Ø 10	1		Ms	10014906	NSt	10014908
59	Jet connecting piece G 1/2 internal, jet Ø 10	1		Ms	10015100	NSt	10015103
60	Plug M 12x1.5	1		Ms	10015022	NSt	10015025
61	Sealing ring	2	W	LM	18796	LM	18796
62	Straight pin	1		NSt	17049	NSt	17049

4.2.1 Spare parts drawing – type with measuring unit F
 Jet - Ø2, Ø3.7 and Ø5.5

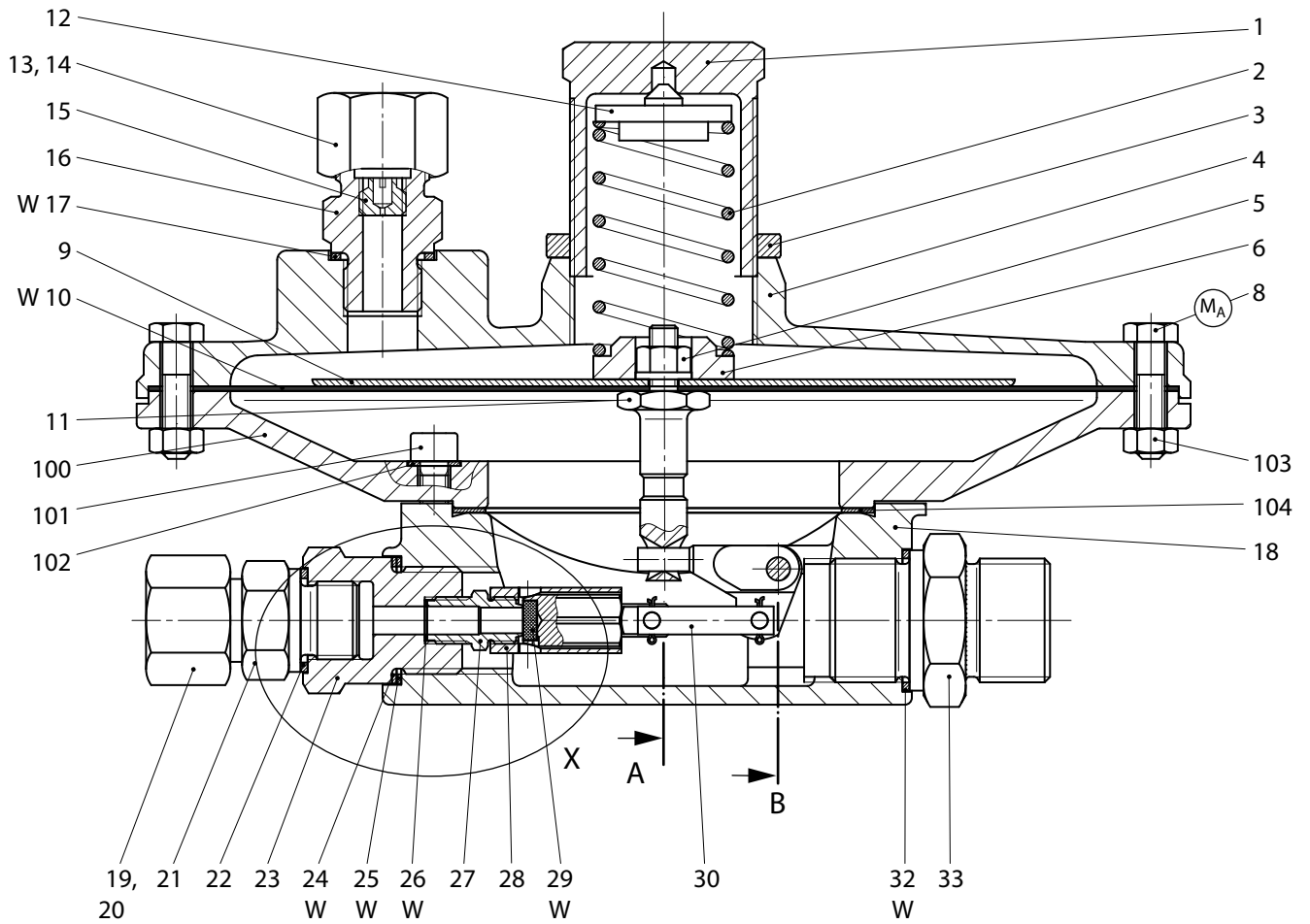

M_A Be sure to comply with tightening torques in table on page 4.

W Parts should be held in stock for maintenance purposes.

For section views see page 6.

4.2.2 Spare parts list – type with measuring unit F

Item no.	Denomination	Number	W	Standard version		Ammonia version		
				Materials	Part no.	Materials	Part no.	
1	Adjusting screw	1		Ms	10014910	NSt	10014911	
2	Control spring, optional:							
2	Control spring F1 Ø 2.5 for Wds 0.003 to 0.016 bar (white)	1		FSt	10014926	FSt	10014926	
2	Control spring F2 Ø 3.0 for Wds 0.006 to 0.040 bar (yellow)	1		FSt	10015469	FSt	10015469	
3	Threaded ring	1		LM	10014900	LM	10014900	
4	Cap	1		GLM	10015462	GLM	10015462	
5	Hex collar nut	1		St/KG	13138	St/KG	13138	
6	Spring plate	1		St	10015471	St	10015471	
8	Hex screw	12		St	6179	St	6179	
9	Diaphragm disc	1		LM	10015465	LM	10015465	
10	Diaphragm, optional:							
10	Diaphragm Wd up to 16 mbar (0.5 mm thick)	1	W	KG	10015466	KG	10019409	
10	Diaphragm Wd up to 40 mbar (1.0 mm thick)	1	W	KG	10015468	KG	10019410	
11	Lever eye	1		NSt	10016674	NSt	10016674	
12	Compensation piece	1		NSt	10014932	NSt	10014932	
13	Union nut	1		St	30805	St	30805	
14	Cutting ring	1		St	30904	St	30904	
15	Dosing screw	1		Ms	10005096	NSt	10005097	
16	Connection pipe	1		St	10007639	St	10007639	
17	Sealing ring	1	W	LM	18688	LM	18688	
18	Body, optional:							
18	Housing for jet Ø 2 to Ø 8	1		GLM	10016694	GLM	10016694	
18	Housing for jet Ø 10	1		GLM	10016695	GLM	10016695	
19	Cap nut, optional:							
19	Cap nut for pipe Ø 10	1		St	30802	St	30802	
19	Cap nut for pipe Ø 12	1		St	30805	St	30805	
19	Cap nut for pipe Ø 16	1		St	30807	St	30807	
20	Compression joint, optional:							
20	Compression joint for pipe Ø 10	1		St	30903	St	30903	
20	Compression joint for pipe Ø 12	1		St	30904	St	30904	
20	Compression joint for pipe Ø 16	1		St	30906	St	30906	
21	Nozzle, optional:							
21	Nozzle for pipe Ø 10	1		St	30102	St	30102	
21	Nozzle for pipe Ø 12	1		St	30104	St	30104	
21	Nozzle for pipe Ø 16	1		St	30106	St	30106	
22	Sealing ring, at option:							
22	Sealing ring for pipes Ø 10 and Ø 12	1		LM	18688	LM	18688	
22	Sealing ring for pipe Ø 16	1		LM	18684	LM	18684	
23	Distance piece, at option:							
23	Distance piece for pipes Ø 10 and Ø 12	1		Ms	10015071	NSt	10015073	
23	Distance piece for pipe Ø 16		1		Ms	10015075	NSt	10015077
23	Distance piece for G 3/4 external	1		Ms	10016726	NSt	10016728	
24	Sealing ring 1 mm	1	W	LM	18814	LM	18814	
25	Sealing ring 1.5 mm	1	W	LM	18815	LM	18815	
26	Sealing ring	1	W	LM	18811	LM	18811	

Spare parts list – type with measuring unit F

Item no.	Denomination	Number	W	Standard version		Ammonia version	
				Materials	Part no.	Materials	Part no.
27	Jet, at option:						
27	Jet Ø 2	1		Ms	10014458	NSt	10014460
27	Jet Ø 3.7	1		Ms	10014462	NSt	10014464
27	Jet Ø 5.5	1		Ms	10014466	NSt	10014468
28	Piston guide	1		Ms	10014470	NSt	10014471
29	Sealing shim, at option:						
29	Sealing shim for jet Ø 2, Ø 3.7, Ø 5.5	1	W	KG	10014473	KG	10014476
29	Sealing shim for jet Ø 8	1	W	KG	10014485	KG	10014487
29	Sealing shim for jet Ø 10	1	W	KG	10014495	KG	10015106
30	Joint, pre-assembled, optional:						
30	Joint, pre-assembled, for jet Ø 2, Ø 3.7, Ø 5.5	1		Ms/NSt	10014452	NSt	10014453
30	Joint, pre-assembled, for jet Ø 8	1		Ms/NSt	10014477	NSt	10014478
30	Joint, pre-assembled, for jet Ø 10	1		Ms/NSt	10014489	NSt	10014490
31	Round-head screw	1		Ms	8608	St	11126
32	Sealing ring	1	W	LM	4428	LM	4428
33	Distance piece for G 3/4 external	1		Ms	10016757	NSt	10016758
50	Plug G 1/4	1		Ms	10016698	NSt	10016699
51	Sealing ring	2	W	LM	18818	LM	18818
Safety valve for response pressure up to 5 bar, choose from items 52 - 58:		1			10019427		10019431
52	Safety valve body	1		LM	10014073	LM	10014073
53	Sealing shim	1	W	KG	10014082	KG	10014085
54	Valve cone	1		Ms	10014078	NSt	10014079
55	Control spring Ø 1.2	1		NFSt	10014077	NFSt	10014077
56	Distance piece	1		St	10015036	St	10015036
57	Union nut	1		St	30805	St	30805
58	Cutting ring	1		St	30904	St	30904
59	Jet connecting piece, at option:						
59	Jet connecting piece G 3/4a, jet Ø 8	1		Ms	10015094	NSt	10015096
59	Jet connecting piece G 1/2 internal, jet Ø 8	1		Ms	10015090	NSt	10015093
59	Jet connecting piece G 3/4a, jet Ø 10	1		Ms	10014906	NSt	10014908
59	Jet connecting piece G 1/2 internal, jet Ø 10	1		Ms	10015100	NSt	10015103
60	Plug M 12x1.5	1		Ms	10015022	NSt	10015025
61	Sealing ring	2	W	LM	18796	LM	18796
62	Straight pin	1		NSt	17049	NSt	17049
100	Intermediate ring	1		GLM	10016691	GLM	10016691
101	Cheese head screw	6		St	10055	St	10055
102	Sealing ring	6	W	LM	18818	LM	18818
103	Hex nut	12		St	3399	St	3399
104	Sealing ring	1	W	KG	8032	KG	20764

4.3.1 Spare parts drawing – type with measuring unit V
 Jet - Ø 2, Ø 3.7 and Ø 5.5

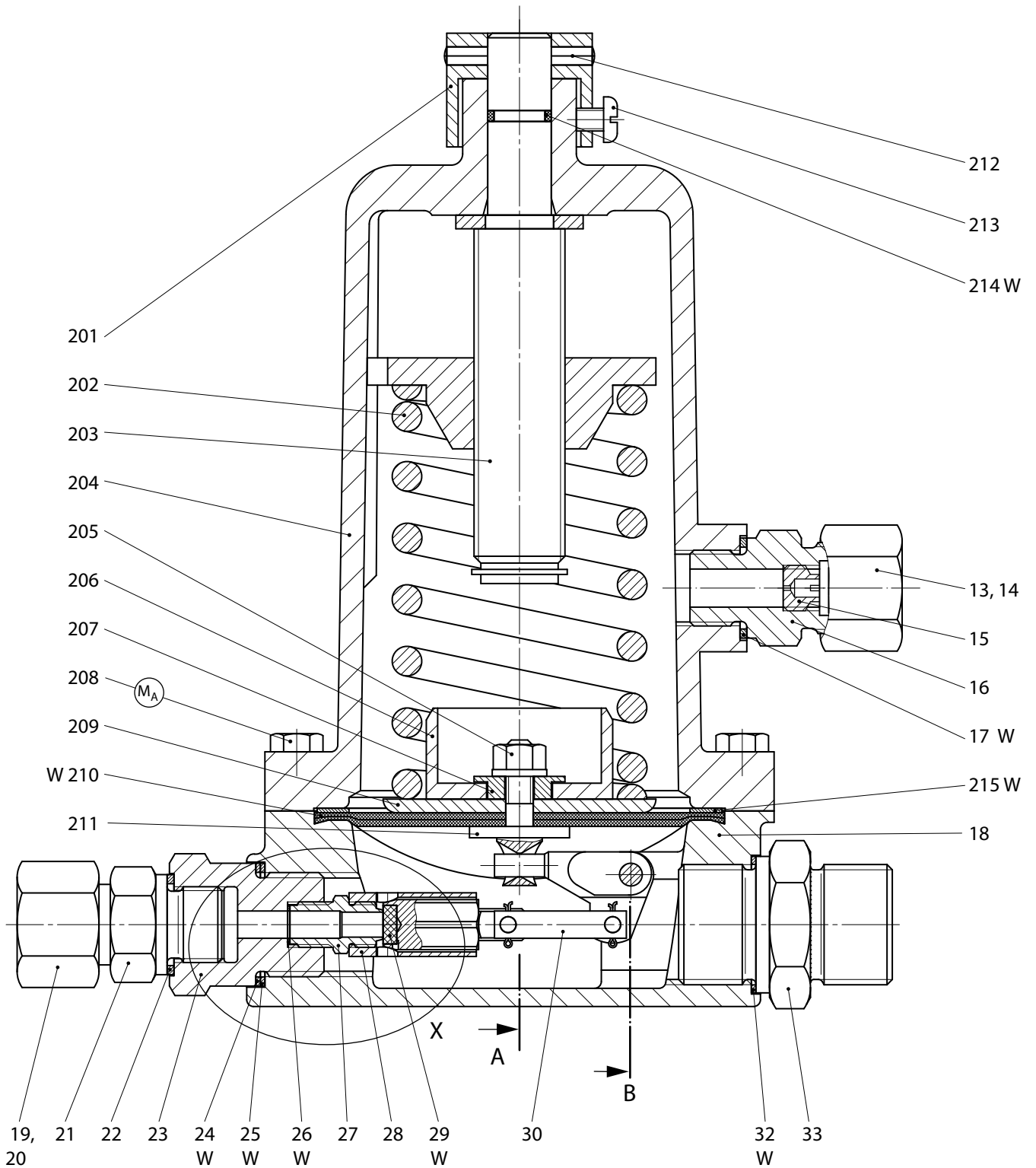

M_A Be sure to comply with tightening torques in table on page 4.
 W Parts should be held in stock for maintenance purposes.

For section views see page 6.

4.3.2 Spare parts list – type with measuring unit V

Item no.	Denomination	Number	W	Standard version		Ammonia version	
				Materials	Part no.	Materials	Part no.
13	Union nut	1		St	30805	St	30805
14	Cutting ring	1		St	30904	St	30904
15	Dosing screw	1		Ms	10005096	NSt	10005097
16	Connection pipe	1		St	10007639	St	10007639
17	Sealing ring	1	W	LM	18688	LM	18688
18	Body, optional:						
18	Housing for jet Ø 2 to jet Ø 8	1		GLM	10016694	GLM	10016694
18	Housing for jet Ø 10	1		GLM	10016695	GLM	10016695
19	Cap nut, optional:						
19	Cap nut for pipe Ø 10	1		St	30802	St	30802
19	Cap nut for pipe Ø 12	1		St	30805	St	30805
19	Cap nut for pipe Ø 16	1		St	30807	St	30807
20	Compression joint, optional:						
20	Compression joint for pipe Ø 10	1		St	30903	St	30903
20	Compression joint for pipe Ø 12	1		St	30904	St	30904
20	Compression joint for pipe Ø 16	1		St	30906	St	30906
21	Nozzle, optional:						
21	Nozzle for pipe Ø 10	1		St	30103	St	30103
21	Nozzle for pipe Ø 12	1		St	30104	St	30104
21	Nozzle for pipe Ø 16	1		St	30106	St	30106
22	Sealing ring, at option:						
22	Sealing ring for pipes Ø 10 and Ø 12	1		LM	18688	LM	18688
22	Sealing ring for pipe Ø 16	1		LM	18684	LM	18684
23	Distance piece, at option:						
23	Distance piece for pipes Ø 10 and Ø 12	1		Ms	10015071	NSt	10015073
23	Distance piece for pipe Ø 16		1		Ms	10015075	NSt
23	Distance piece for G 3/4 external	1		Ms	10016726	NSt	10016728
24	Sealing ring 1 mm	1	W	LM	18814	LM	18814
25	Sealing ring 1.5 mm	1	W	LM	18815	LM	18815
26	Sealing ring	1	W	LM	18811	LM	18811
27	Jet, at option:						
27	Jet Ø 2	1		Ms	10014458	NSt	10014460
27	Jet Ø 3.7	1		Ms	10014462	NSt	10014464
27	Jet Ø 5.5	1		Ms	10014466	NSt	10014468
28	Piston guide	1		Ms	10014470	NSt	10014471
29	Sealing shim, at option:						
29	Sealing shim for jet Ø 2, Ø 3.7, Ø 5.5	1	W	KG	10014473	KG	10014476
29	Sealing shim for jet Ø 8	1	W	KG	10014485	KG	10014487
29	Sealing shim for jet Ø 10	1	W	KG	10014495	KG	10015106
30	Joint, pre-assembled, optional:						
30	Joint, pre-assembled, for jet Ø 2, Ø 3.7, Ø 5.5	1		NSt/Ms	10014452	NSt	10014453
30	Joint, pre-assembled, for jet Ø 8	1		NSt/Ms	10014477	NSt	10014478
30	Joint, pre-assembled, for jet Ø 10	1		NSt/Ms	10014489	NSt	10014490

Spare parts list – type with measuring unit V

Item no.	Denomination	Number	W	Standard version		Ammonia version		
				Materials	Part no.	Materials	Part no.	
31	Round-head screw	1		Ms	8608	St	11126	
32	Sealing ring	1	W	LM	4428	LM	4428	
33	Distance piece for G 3/4 external	1		Ms	10016757	NSt	10016758	
50	Plug G 1/4	1		Ms	10016698	NSt	10016699	
51	Sealing ring	2	W	LM	18818	LM	18818	
	Safety valve for response pressure up to 10 bar, choose from items 52 - 58:	1			10019428		10019432	
52	Safety valve body		1		LM	10014073	LM	10014073
53	Sealing shim	1	W	KG	10014082	KG	10014085	
54	Valve cone	1		Ms	10014078	NSt	10014079	
55	Control spring Ø 1.6	1		NFSt	10016712	NFSt	10016712	
56	Distance piece	1		St	10015036	St	10015036	
57	Union nut	1		St	30805	St	30805	
58	Cutting ring	1		St	30904	St	30904	
59	Jet connecting piece, at option:							
59	Jet connecting piece G 3/4 external for jet Ø 8	1		Ms	10015094	NSt	10015096	
59	Jet connecting piece G 1/2 internal for jet Ø 8	1		Ms	10015090	NSt	10015093	
59	Jet connecting piece G 3/4 external for jet Ø 10	1		Ms	10014906	NSt	10014908	
59	Jet connecting piece G 1/2 internal for jet Ø 10	1		Ms	10015100	NSt	10015103	
60	Plug M 12x1.5	1		Ms	10015022	NSt	10015025	
61	Sealing ring	2	W	LM	18796	LM	18796	
62	Straight pin	1		NSt	17049	NSt	17049	
201	Hex adjusting ring	1		NSt	10014954	NSt	10014954	
202	Control spring, optional:							
202	Control spring F4 Ø 4.5 for Wds 0.1 to 1 bar	1		FSt	10014960	FSt	10014960	
202	Control spring F5 Ø 6 for Wds 0.2 to 2 bar	1		FSt	10014961	FSt	10014961	
202	Control spring F6 Ø 6.5 for Wds 0.4 to 4 bar	1		FSt	10014962	FSt	10014962	
202	Control spring F7 Ø 8 for Wds 0.7 to 7 bar	1		FSt	10014963	FSt	10014963	
202	Control spring F8 Ø 9 for Wds 0.8 to 8 bar	1		FSt	10014964	FSt	10014964	
203	Adjusting spindle, complete	1		NSt/Ms	10014949	NSt	10014948	
204	Cap	1		GLM	10015006	GLM	10015006	
205	Hex collar nut	1		St	13138	St	13138	
206	Spring plate	1		LM	10014942	LM	10014942	
207	Distance piece	1		LM	10014522	LM	10014522	
208	Hex screw	6		St	10336	St	10336	
209	Diaphragm disc	1		St	10014983	St	10014983	
210	Diaphragm (3 mm thick)	1	W	KG	10014989	KG	10018122	
211	Lever eye	1		NSt	10014993	NSt	10014993	
212	Grooved taper pin		1		St	6646	St	6646
213	Flat head screw	1		St	5888	St	5888	
214	O ring	1	W	KG	20331	KG	20331	
215	Ring	1	W	KG	10015450	KG	10015450	

4.4.1 Type with measuring unit G

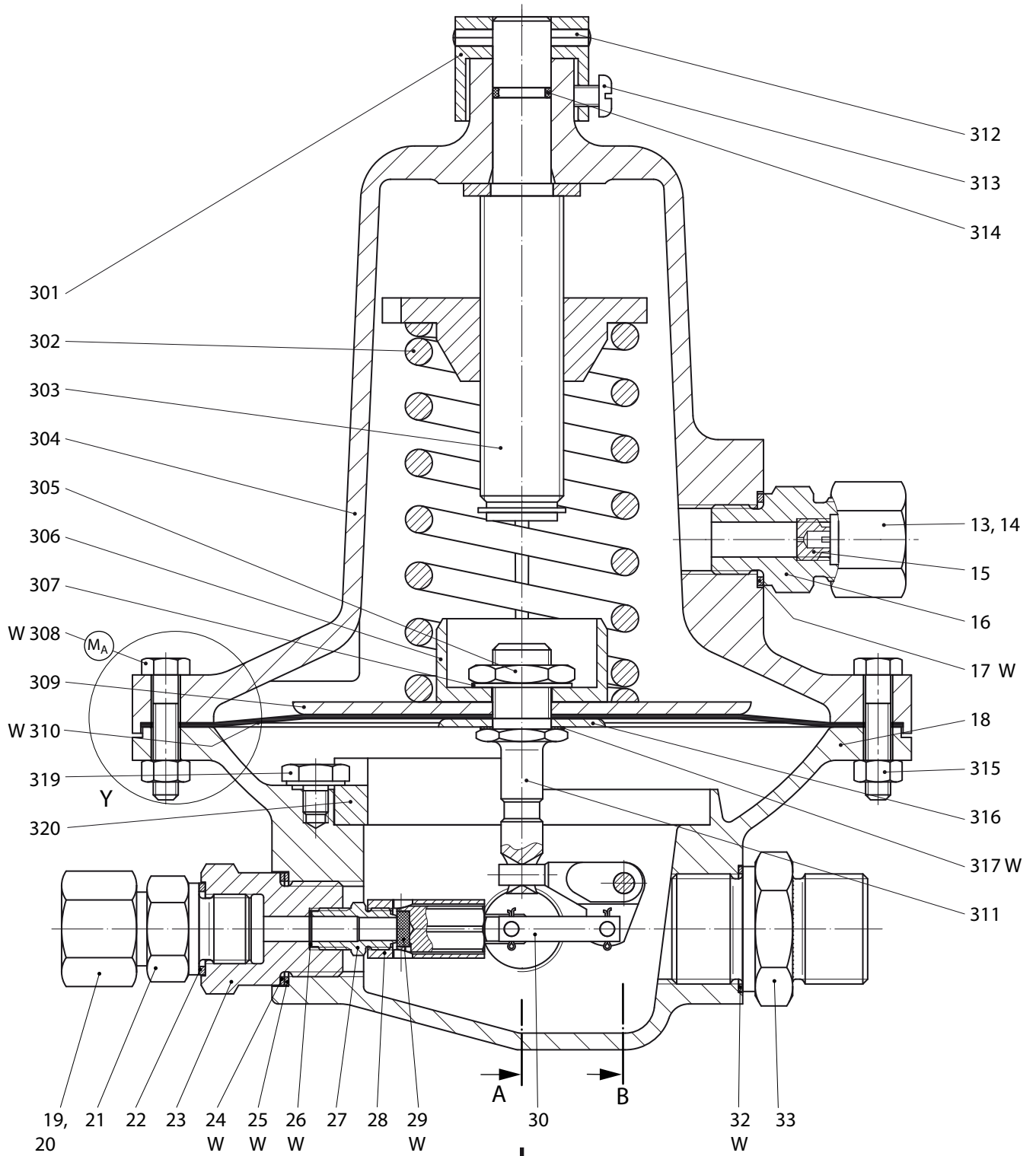

Type with springs F4 to F8

Type with springs F1 to F3

"Y"
(only for 0.4 mm diaphragm)

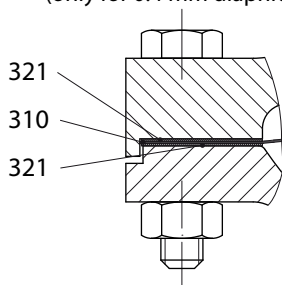

M_A Be sure to comply with tightening torques in table on page 4.

W Parts should be held in stock for maintenance purposes.

For section views see page 6.

4.4.2 Spare parts list – type with measuring unit G

Item no.	Denomination	Number	W	Standard version		Ammonia version		
				Materials	Part no.	Materials	Part no.	
13	Union nut	1		St	30805	St	30805	
14	Cutting ring	1		St	30904	St	30904	
15	Dosing screw	1		Ms	10005096	NSt	10005097	
16	Connection pipe	1		St	10007639	St	10007639	
17	Sealing ring	1	W	LM	18688	LM	18688	
18	Body, optional:							
18	Housing for jet Ø 2 to Ø 8	1		GLM	10016703	GLM	10016703	
18	Housing for jet Ø 10	1		GLM	10016644	GLM	10016644	
19	Cap nut, optional:							
19	Cap nut for pipe Ø 10	1		St	30802	St	30802	
19	Cap nut for pipe Ø 12	1		St	30805	St	30805	
19	Cap nut for pipe Ø 16	1		St	30807	St	30807	
20	Compression joint, optional:							
20	Compression joint for pipe Ø 10	1		St	30903	St	30903	
20	Compression joint for pipe Ø 12	1		St	30904	St	30904	
20	Compression joint for pipe Ø 16	1		St	30906	St	30906	
21	Nozzle, optional:							
21	Nozzle for pipe Ø 10	1		St	30102	St	30102	
21	Nozzle for pipe Ø 12	1		St	30104	St	30104	
21	Nozzle for pipe Ø 16	1		St	30106	St	30106	
22	Sealing ring, at option:							
22	Sealing ring for pipes Ø 10 and Ø 12	1		LM	18688	LM	18688	
22	Sealing ring for pipe Ø 16	1		LM	18684	LM	18684	
23	Distance piece, at option:							
23	Distance piece for pipes Ø 10 and Ø 12	1		Ms	10015071	NSt	10015073	
23	Distance piece for pipe Ø 16		1		Ms	10015075	NSt	10015077
23	Distance piece for G 3/4 external	1		Ms	10016726	NSt	10016728	
24	Sealing ring 1 mm	1	W	LM	18814	LM	18814	
25	Sealing ring 1.5 mm	1	W	LM	18815	LM	18815	
26	Sealing ring	1	W	LM	18811	LM	18811	
27	Jet, at option:							
27	Jet Ø 2	1		Ms	10014458	NSt	10014460	
27	Jet Ø 3.7	1		Ms	10014462	NSt	10014464	
27	Jet Ø 5.5	1		Ms	10014466	NSt	10014468	
28	Piston guide	1		Ms	10014470	NSt	10014471	
29	Sealing shim, at option:							
29	Sealing shim for jet Ø 2, Ø 3.7, Ø 5.5	1	W	KG	10014473	KG	10014476	
29	Sealing shim for jet Ø 8	1	W	KG	10014485	KG	10014487	
29	Sealing shim for jet Ø 10	1	W	KG	10014495	KG	10015106	
30	Joint, pre-assembled, optional:							
30	Joint, pre-assembled, for jet Ø 2, Ø 3.7, Ø 5.5	1		NSt/Ms	10014452	NSt	10014453	
30	Joint, pre-assembled, for jet Ø 8	1		NSt/Ms	10014477	NSt	10014478	
30	Joint, pre-assembled, for jet Ø 10	1		NSt/Ms	10014489	NSt	10014490	
31	Round-head screw	1		Ms	8608	St	11126	
32	Sealing ring	1	W	LM	4428	LM	4428	
33	Distance piece for G 3/4 external	1		Ms	10016757	NSt	10016758	
50	Plug G 1/4	1		Ms	10016698	NSt	10016699	
51	Sealing ring	2	W	LM	18818	LM	18818	

Spare parts list – type with measuring unit G

Item no.	Denomination	Number	W	Standard version		Ammonia version		
				Materials	Part no.	Materials	Part no.	
	Safety valve for response pressure up to 5 bar, choose from items 52 - 58:	1			10019427		10019431	
52	Safety valve body	1			LM	10014073	LM	10014
53	Sealing shim	1	W	KG	10014082	KG	10014085	
54	Valve cone	1		Ms	10014078	NSt	10014079	
55	Control spring Ø 1.2	1		NFSt	10014077	NFSt	10014077	
56	Distance piece	1		St	10015036	St	10015036	
57	Union nut	1		St	30805	St	30805	
58	Cutting ring	1		St	30904	St	30904	
59	Jet connecting piece, at option:							
59	Jet connecting piece G 3/4a, jet Ø 8	1		Ms	10015094	NSt	10015096	
59	Jet connecting piece G 1/2 internal, jet Ø 8	1		Ms	10015090	NSt	10015093	
59	Jet connecting piece G 3/4 external for jet Ø 10	1		Ms	10014906	NSt	10014908	
59	Jet connecting piece G 1/2 internal, jet Ø 10	1		Ms	10015100	NSt	10015103	
60	Plug M 12x1.5	1		Ms	10015022	NSt	10015025	
61	Sealing ring	2	W	LM	18796	LM	18796	
62	Straight pin	1		NSt	17122	NSt	17122	
301	Hex adjusting ring	1		NSt	10014954	NSt	10014954	
302	Control spring, optional:							
302	Control spring F1 Ø 2.5 for Wds 0.008 to 0.012 bar	1		FSt	10014957	FSt	10014957	
302	Control spring F2 Ø 3 for Wds 0.01 to 0.04 bar	1		FSt	10014958	FSt	10014958	
302	Control spring F3 Ø 4 for Wds 0.03 to 0.1 bar	1		FSt	10014959	FSt	10014959	
302	Control spring F4 Ø 4.5 for Wds 0.03 to 0.25 bar	1		FSt	10014960	FSt	10014960	
302	Control spring F5 Ø 6 for Wds 0.05 to 0.5 bar	1		FSt	10014961	FSt	10014961	
302	Control spring F6 Ø 6.5 for Wds 0.1 to 1.0 bar	1		FSt	10014962	FSt	10014962	
302	Control spring F7 Ø 8 for Wds 0.2 to 1.8 bar	1		FSt	10014963	FSt	10014963	
302	Control spring F8 Ø 9 for Wds 0.3 to 2.0 bar	1		FSt	10014964	FSt	10014964	
303	Adjusting spindle, complete	1		NSt/Ms	10014949	NSt	10014948	
304	Cap	1		GLM	10014955	GLM	10014955	
305	Hex nut	1		St	10014696	St	10014696	
306	Spring plate	1		LM	10014942	LM	10014942	
307	Tooth lock washer		1		FSt	14107	FSt	14107
308	Hex screw	10		St	10336	St	10336	
309	Diaphragm disc	1		St	10014820	St	10014820	
310	Diaphragm, optional:							
310	Diaphragm up to 0.04 bar (0.4 mm thick)	1	W	KG	10014905	KG	10019405	
310	Diaphragm up to 0.1 bar (1.0 mm thick)	1	W	KG	10014967	KG	10018106	
310	Diaphragm up to 1.0 bar (2.0 mm thick)	1	W	KG	10014968	KG	10014969	
310	Diaphragm up to 2.0 bar (2.5 mm thick)	1	W	KG	10014970	KG	10018118	
311	Lever eye	1		NSt	10016683	NSt	10016683	
312	Grooved taper pin		1		St	6646	St	6646
313	Flat head screw	1		St	5888	St	5888	
314	O ring	1	W	KG	20331	KG	20331	
315	Hex nut	10		St	3399	St	3399	
316	Diaphragm disc	1		Ms	10014971	NSt	10014973	
317	Sealing ring	1	W	KG	20693	KG	20746	
319	Retaining screw (for springs F4 to F8)	3		Ms	10016688	NSt	10016690	
320	Diaphragm support ring (for springs F4 to F8)	1		LM	10016687	LM	10016687	
321	Sealing ring (only for 0.4 mm diaphragm)	2	W	KG	10015116	KG	10015116	

4.5.1 Spare parts drawing – type with measuring unit GS
 Jet - Ø 2, Ø 3.7 and Ø 5.5

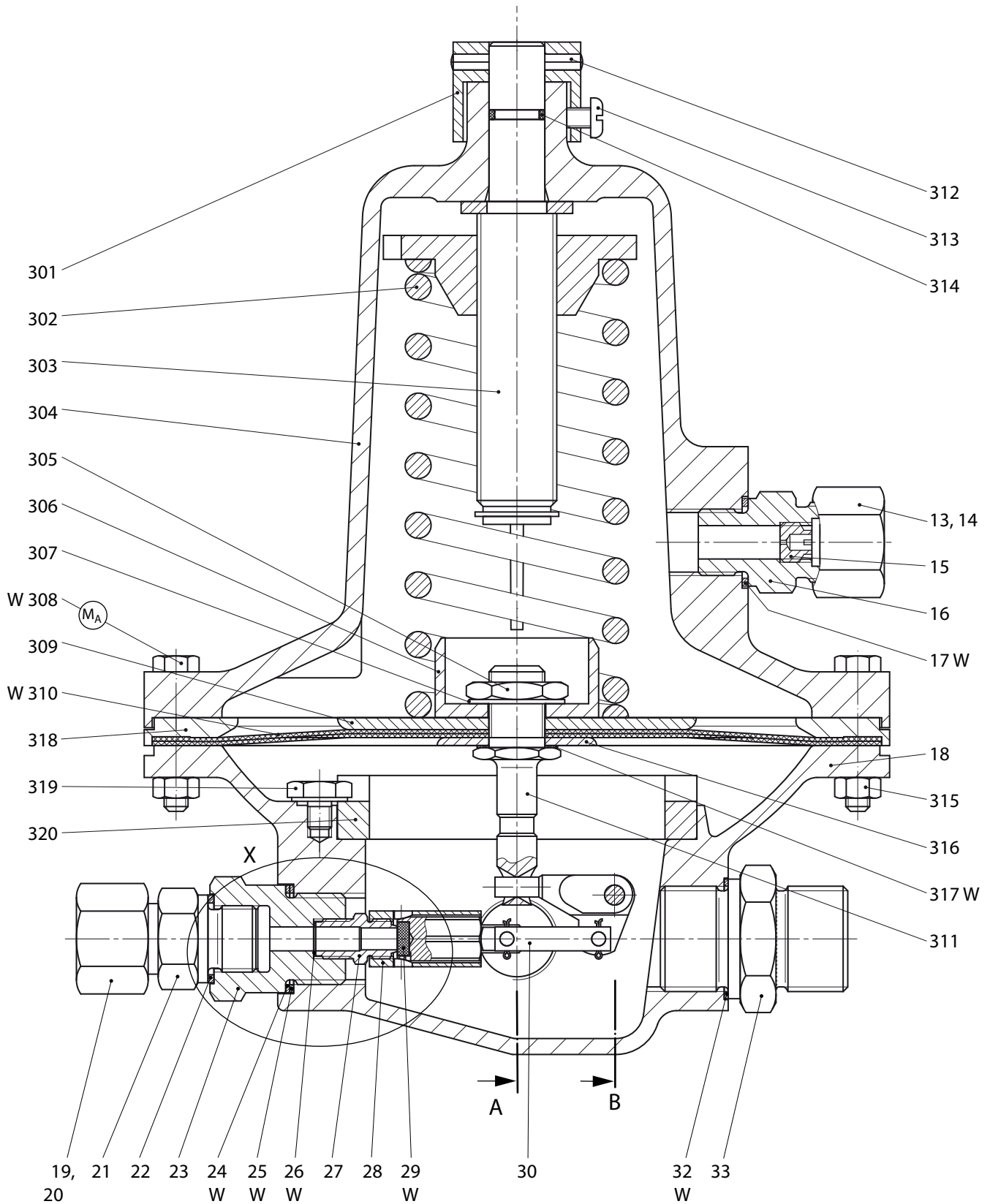

M_A Be sure to comply with tightening torques in table on page 4.
 W Parts should be held in stock for maintenance purposes.

For section views see page 6.

4.5.2 Spare parts list – type with measuring unit GS

Item no.	Denomination	Number	W	Standard version		Ammonia version	
				Materials	Part no.	Materials	Part no.
13	Union nut	1		St	30805	St	30805
14	Cutting ring	1		St	30904	St	30904
15	Dosing screw	1		Ms	10005096	NSt	10005097
16	Connection pipe	1		St	10007639	St	10007639
17	Sealing ring	1	W	LM	18688	LM	18688
18	Body, optional:						
18	Housing for jet Ø 2 to Ø 8	1		GLM	10016703	GLM	10016703
18	Housing for jet Ø 10	1		GLM	10016644	GLM	10016644
19	Cap nut, optional:						
19	Cap nut for pipe Ø 10	1		St	30802	St	30802
19	Cap nut for pipe Ø 12	1		St	30805	St	30805
19	Cap nut for pipe Ø 16	1		St	30807	St	30807
20	Compression joint, optional:						
20	Compression joint for pipe Ø 10	1		St	30903	St	30903
20	Compression joint for pipe Ø 12	1		St	30904	St	30904
20	Compression joint for pipe Ø 16	1		St	30906	St	30906
21	Nozzle, optional:						
21	Nozzle for pipe Ø 10	1		St	30102	St	30102
21	Nozzle for pipe Ø 12	1		St	30104	St	30104
21	Nozzle for pipe Ø 16	1		St	30106	St	30106
22	Sealing ring, at option:						
22	Sealing ring for pipes Ø 10 and Ø 12	1		LM	18688	LM	18688
22	Sealing ring for pipe Ø 16	1		LM	18684	LM	18684
23	Distance piece, at option:						
23	Distance piece for pipes Ø 10 and Ø 12	1		Ms	10015071	NSt	10015073
23	Distance piece for pipe Ø 16		1		Ms	10015075	NSt
23	Distance piece for G 3/4 external	1		Ms	10016726	NSt	10016728
24	Sealing ring 1 mm	1	W	LM	18814	LM	18814
25	Sealing ring 1.5 mm	1	W	LM	18815	LM	18815
26	Sealing ring	1	W	LM	18811	LM	18811
27	Jet, at option:						
27	Jet Ø 2	1		Ms	10014458	NSt	10014460
27	Jet Ø 3.7	1		Ms	10014462	NSt	10014464
27	Jet Ø 5.5	1		Ms	10014466	NSt	10014468
28	Piston guide	1		Ms	10014470	NSt	10014471
29	Sealing shim, at option:						
29	Sealing shim for jet Ø 2, Ø 3.7, Ø 5.5	1	W	KG	10014473	KG	10014476
29	Sealing shim for jet Ø 8	1	W	KG	10014485	KG	10014487
29	Sealing shim for jet Ø 10	1	W	KG	10014495	KG	10015106
30	Joint, pre-assembled, optional:						
30	Joint, pre-assembled, for jet Ø 2, Ø 3.7, Ø 5.5	1		NSt/Ms	10014452	NSt	10014453
30	Joint, pre-assembled, for jet Ø 8	1		NSt/Ms	10014477	NSt	10014478
30	Joint, pre-assembled, for jet Ø 10	1		NSt/Ms	10014489	NSt	10014490

Spare parts list – type with measuring unit GS

Item no.	Denomination	Number	W	Standard version		Ammonia version		
				Materials	Part no.	Materials	Part no.	
31	Round-head screw	1		Ms	8608	St	11126	
32	Sealing ring	1	W	LM	4428	LM	4428	
33	Distance piece for G 3/4 external	1		Ms	10016757	NSt	10016758	
50	Plug G 1/4	1		Ms	10016698	NSt	10016699	
51	Sealing ring	2	W	LM	18818	LM	18818	
	Safety valve for response pressure up to 5 bar, choose from items 52 - 58:	1			10019427		10019431	
52	Safety valve body		1		LM	10014073	LM	10014073
53	Sealing shim	1	W	KG	10014082	KG	10014085	
54	Valve cone	1		Ms	10014078	NSt	10014079	
55	Control spring Ø 1.2	1		NFSt	10014077	NFSt	10014077	
56	Distance piece	1		St	10015036	St	10015036	
57	Union nut	1		St	30805	St	30805	
58	Cutting ring	1		St	30904	St	30904	
59	Jet connecting piece, at option:							
59	Jet connecting piece G 3/4a, jet Ø 8	1		Ms	10015094	NSt	10015096	
59	Jet connecting piece G 1/2 internal, jet Ø 8	1		Ms	10015090	NSt	10015093	
59	Jet connecting piece G 3/4 external for jet Ø 10	1		Ms	10014906	NSt	10014908	
59	Jet connecting piece G 1/2 internal, jet Ø 10	1		Ms	10015100	NSt	10015103	
60	Plug M 12x1.5	1		Ms	10015022	NSt	10015025	
61	Sealing ring	2	W	LM	18796	LM	18796	
62	Straight pin	1		NSt	17122	NSt	17122	
301	Hex adjusting ring	1		NSt	10014954	NSt	10014954	
302	Control spring, optional:							
302	Control spring F7 Ø 8 for Wds 0.25 to 2.5 bar	1		FSt	10014963	FSt	10014963	
302	Control spring F8 Ø 9 for Wds 0.35 to 3.5 bar	1		FSt	10014964	FSt	10014964	
303	Adjusting spindle, complete	1		NSt/Ms	10014949	NSt	10014948	
304	Cap	1		GLM	10014955	GLM	10014955	
305	Hex nut	1		St	10014696	St	10014696	
306	Spring plate	1		LM	10014942	LM	10014942	
307	Tooth lock washer		1		FSt	14107	FSt	14107
308	Hex screw	10		St	10024	St	10024	
309	Diaphragm disc	1		St	10014981	St	10014981	
310	Diaphragm (2.5 mm thick)	1	W	KG	10014970	KG	10018118	
311	Lever eye	1		NSt	10016683	NSt	10016683	
312	Grooved taper pin		1		St	6646	St	6646
313	Flat head screw	1		St	5888	St	5888	
314	O ring	1	W	KG	20331	KG	20331	
315	Hex nut	10		St	3399	St	3399	
316	Diaphragm disc	1		Ms	10014971	NSt	10014973	
317	Sealing ring	1	W	KG	20693	KG	20746	
318	Intermediate ring		1		LM	10014980	LM	10014980
319	Retaining screw	3		Ms	10016688	NSt	10016690	
320	Diaphragm support ring	1		LM	10016687	LM	10016687	

5. Parts for maintenance purposes

Item no.	Denomination	Number	Part no.	
			Standard version	Ammonia version
Parts for measuring unit M				
10	Diaphragm	1	10014989	10018122
17	Sealing ring	1	18688	18688
24	Sealing ring 1 mm	1	18814	18814
25	Sealing ring 1.5 mm	1	18815	18815
26	Sealing ring	1	18811	18811
29	Sealing shim, at option:			
29	Sealing shim for jet \varnothing 2, \varnothing 3.7, \varnothing 5.5	1	10014473	10014476
29	Sealing shim for jet \varnothing 8	1	10014485	10014487
29	Sealing shim for jet \varnothing 10	1	10014495	10015106
32	Sealing ring	1	4428	4428
51	Sealing ring	2	18818	18818
53	Sealing shim	1	10014082	10014085
61	Sealing ring	2	18796	18796
Parts for measuring unit F				
10	Diaphragm, optional:			
10	Diaphragm for W_d up to 16 mbar	1	10015466	10019409
10	Diaphragm for W_d up to 40 mbar	1	10015468	10019410
17	Sealing ring	1	18688	18688
24	Sealing ring 1 mm	1	18814	18814
25	Sealing ring 1.5 mm	1	18815	18815
26	Sealing ring	1	18811	18811
29	Sealing shim, at option:			
29	Sealing shim for jet \varnothing 2, \varnothing 3.7, \varnothing 5.5	1	10014473	10014476
29	Sealing shim for jet \varnothing 8	1	10014485	10014487
29	Sealing shim for jet \varnothing 10	1	10014495	10015106
32	Sealing ring	1	4428	4428
51	Sealing ring	2	18818	18818
53	Sealing shim	1	10014082	10014085
61	Sealing ring	2	18796	18796
102	Sealing ring	1	18818	18818
104	Sealing ring	1	8032	8032
Parts for measuring unit V				
17	Sealing ring	1	18688	18688
24	Sealing ring 1 mm	1	18814	18814
25	Sealing ring 1.5 mm	1	18815	18815
26	Sealing ring	1	18811	18811
29	Sealing shim, at option:			
29	Sealing shim for jet \varnothing 2, \varnothing 3.7, \varnothing 5.5	1	10014473	10014476
29	Sealing shim for jet \varnothing 8	1	10014485	10014487
29	Sealing shim for jet \varnothing 10	1	10014495	10015106
32	Sealing ring	1	4428	4428
51	Sealing ring	2	18818	18818
53	Sealing shim	1	10014082	10014085
61	Sealing ring	1	18796	18796
210	Diaphragm	1	10014989	10018122
214	O ring	1	20331	20331
215	Ring	1	10015450	10015450

Parts for maintenance purposes

Item no.	Denomination	Number	Part no.	
			Standard version	Ammonia version
Parts for measuring unit G				
17	Sealing ring	1	18688	18688
24	Sealing ring 1 mm	1	18814	18814
25	Sealing ring 1.5 mm	1	18815	18815
26	Sealing ring	1	18811	18811
29	Sealing shim, at option:			
29	Sealing shim for jet Ø 2, Ø 3.7, Ø 5.5	1	10014473	10014476
29	Sealing shim for jet Ø 8	1	10014485	10014487
29	Sealing shim for jet Ø 10	1	10014495	10015106
32	Sealing ring	1	4428	4428
51	Sealing ring	2	18818	18818
53	Sealing shim	1	10014082	10014085
61	Sealing ring	2	18796	18796
310	Diaphragm, optional:			
310	Diaphragm up to 0.04 bar	1	10014905	10019405
310	Diaphragm up to 0.1 bar	1	10014967	10018106
310	Diaphragm up to 1.0 bar	1	10014968	10014969
310	Diaphragm up to 2.0 bar	1	10014970	10018118
314	O ring	1	20331	20331
317	Sealing ring	1	20693	20746
321	Sealing ring (for Diaphragm 0.4 mm thick)	1	10015116	10015116
Parts for measuring unit GS				
17	Sealing ring	1	18688	18688
24	Sealing ring 1 mm	1	18814	18814
25	Sealing ring 1.5 mm	1	18815	18815
26	Sealing ring	1	18811	18811
29	Sealing shim, at option:			
29	Sealing shim for jet Ø 2, Ø 3.7, Ø 5.5	1	10014473	10014476
29	Sealing shim for jet Ø 8	1	10014485	10014487
29	Sealing shim for jet Ø 10	1	10014495	10015106
32	Sealing ring	1	4428	4428
51	Sealing ring	2	18818	18818
53	Sealing shim	1	10014082	10014085
61	Sealing ring	2	18796	18796
310	Diaphragm	1	10014970	10018118
314	O ring	1	20331	20331
317	Sealing ring	1	20693	20746

For More Information

To learn more about Honeywell's
Advanced Gas Solutions, visit
www.honeywellprocess.com or contact
your Honeywell account manager

GERMANY**Honeywell Process Solutions**

Honeywell Gas Technologies GmbH
Osterholzstrasse 45
34123 Kassel, Germany
Tel: +49 (0)561 5007-0
Fax: +49 (0)561 5007-107

HON 219.20
2017-01
© 2017 Honeywell International Inc.

Honeywell