

OPERATING AND MAINTENANCE INSTRUCTIONS/
SPARE PARTS

EDITION 01/2017

**Serving the Gas Industry
Worldwide**

Honeywell

1. General

For the safety relief valve HON 832 the detailed product information 832.00 containing technical specifications, dimensions and a description of their construction and operation applies.

The Honeywell publication "General operating instruction for gas pressure regulators and safety devices" contains information on installation, commissioning, and notices on fault finding.

For planning through to the maintenance of gas pressure control systems the relevant national regulations, especially DVGW work sheets G 490, G 491, and G 495 should be observed.

The time intervals for maintenance to the safety relief valve HON 832 depend largely on the operating conditions and the type of gas media used. Therefore, no fixed intervals are being stated.

It is recommended to keep to the maintenance intervals given in the DVGW work sheet G 495.

During maintenance the components must be cleaned and checked carefully.

This is still required even if irregularities are found during operation or functional tests.

The checks must extend to diaphragms and seals and all moveable parts in particular.

The item numbers given in the special operating and maintenance notices correspond to those in the spare part drawing and spare part list.

It is recommended to keep the parts specially marked in the spare part list in stock for maintenance purposes.

2. Special operating notices

2.1 Changing the setting range

setting range W _h in bar	setpoint spring	guide element
0,5 bis 2,0	F 1	sleeve (27)
1,0 bis 4,0	F 2	
2,0 bis 8,0	F 3	
4,0 bis 16,0	F 4	
12,0 bis 30,0	F 5	

4.3 Spare part drawing HON 832 with external vent line

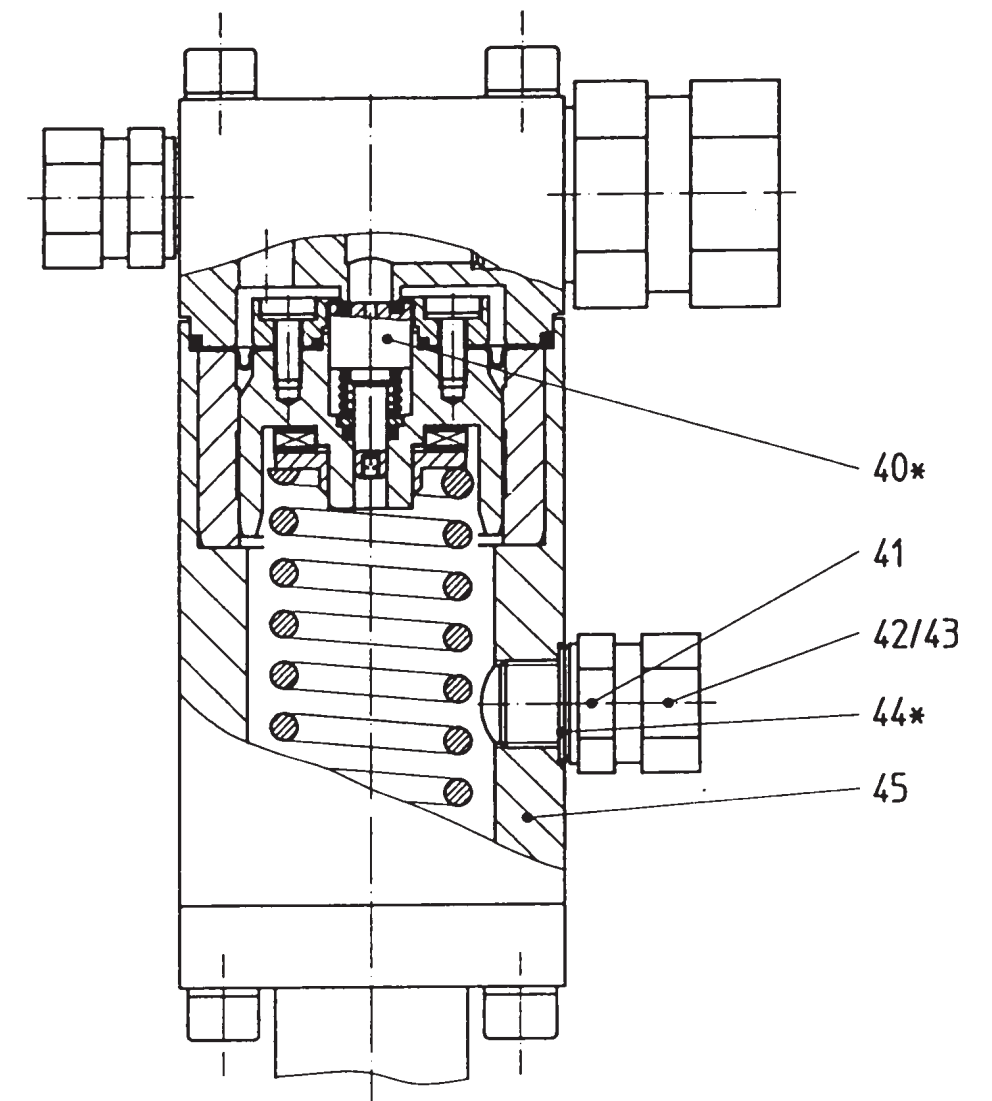

* Keep parts in stock for maintenance purposes

4.4 Spare part list HON 832 with external vent line

item no.	designation	material	part no.
40*	piston	NSt	10 021 855
41	screw adapter, thread M 16x1.5	St	00 030 113
42	union nut	St	00 030 804
43	cutting ring	St	00 030 904
44*	sealing ring	LM	00 018 789
45	spring housing	LM	19 083 222

Parts marked with * should be kept in stock for maintenance purposes.

Material key:

St ... steel

NSt ... stainless steel

LM ... light alloy

4. Spare parts

4.1 Spare part drawing HON 832 with internal vent line

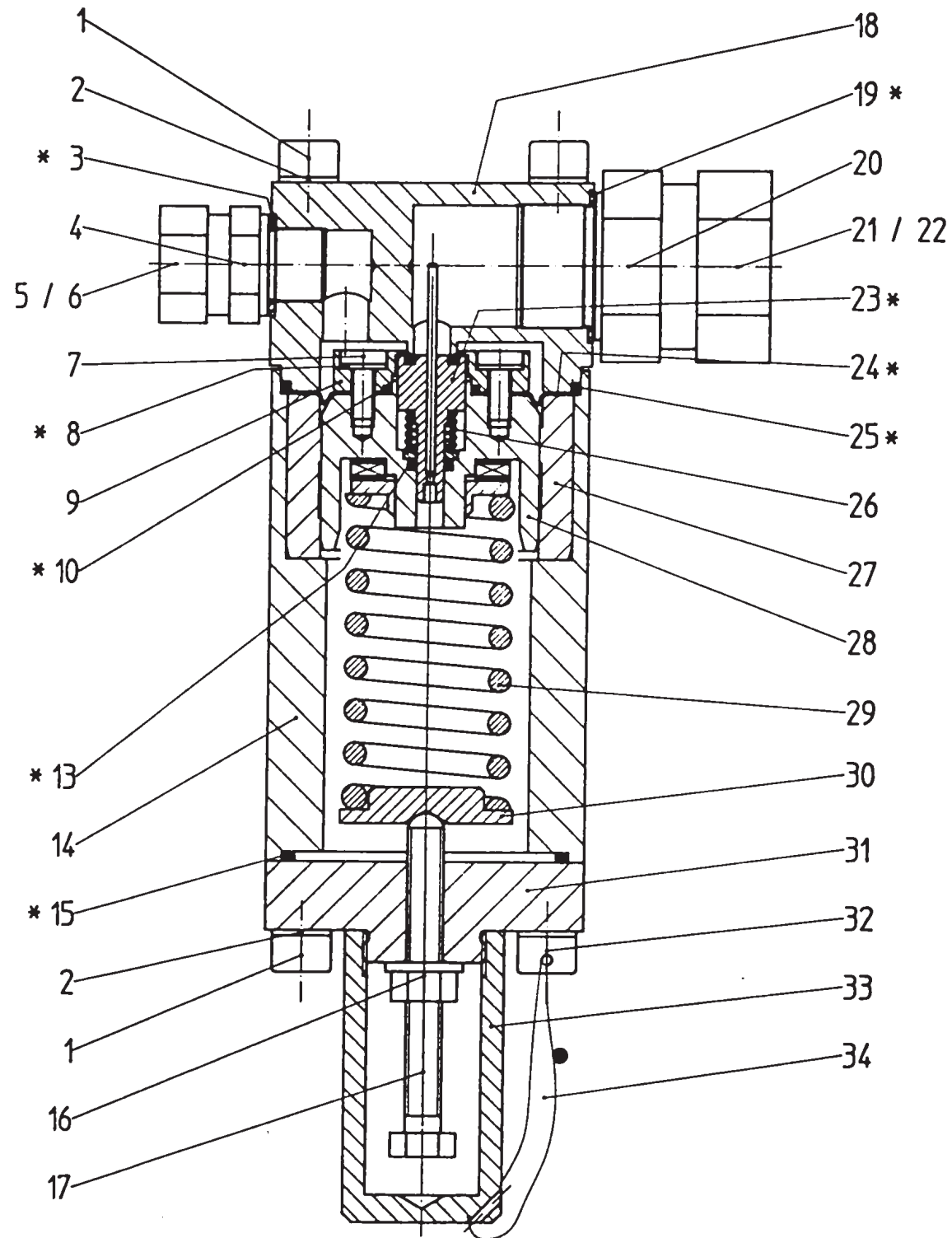

* Keep parts in stock for maintenance purposes

4.2 Spare part list HON 832

item no.	designation	material	part no.
1	cylinder bolt	St	00 010 523
2	locking washer	St	00 014 112
3*	seal	LM	00 018 789
4	screw adapter, for pipe E 12, thread M 16 x 1.5	St	00 030 113
5	union nut	St	00 030 804
6	cutting ring	St	00 030 904
7	flat head screw	St	00 005 418
8*	sealing ring	KG	10 021 568
9	piston retainer	NSt	10 021 328
10*	O ring	KG	00 020 310
13*	O ring	KG	00 020 226
14	spring housing	LM	10 020 907
15*	O ring	KG	00 020 425
16	hexagonal collar nut	St	00 013 136
17	hexagonal screw	St	00 010 541
18	cover	LM	10 020 906
19*	sealing ring	LM	00 018 706
	screw adapter, optionally:		
20	screw adapter for pipe E 20, thread M 27 x 2	St	00 030 145
20	screw adapter for pipe E 25, thread M 27 x 2	St	00 030 181
	union nut, optionally:		
21	union nut for pipe E 20	St	00 030 809
21	union nut for pipe E 25	St	00 030 811
	cutting ring, optionally:		
22	cutting ring for pipe E 20	St	00 030 908
22	cutting ring for pipe E 25	St	00 030 910
23*	assembled piston with vent line	NSt	10 021 324
24*	flange shaped diaphragm	KG	10 027 471
25*	O ring	KG	00 021 037
26	pressure spring	St	10 028 892
27	sleeve	ALBz	10 020 910
28	guide piece	St	10 021 322
	pressure spring, optionally:		
29	pr. spring Wh 0.5 bar to 2 bar (F1)	FSt	10 000 139
29	pr. spring Wh 1 bar to 4 bar (F2)	FSt	10 000 063
29	pr. spring Wh 2 bar to 8 bar (F3)	FSt	10 000 115
29	pr. spring Wh 4 bar to 16 bar (F4)	FSt	10 000 064
29	pr. spring Wh 12 bar to 30 bar (F5)	FSt	10 000 149

Parts marked with * should be kept in stock for maintenance purposes.

Material key:

St	... steel	KG	... rubbery plastic	ALBz	... aluminium bronze
FSt	... spring steel	NSt	... stainless steel		
LM	... light alloy	FSt	... spring steel		

Spare part list HON 832

item no.	designation	material	part no.
	spring plate, optionally:		
30	spring plate Wh 0,5 bar to 2 bar (F1)	LM	10 000 114
30	spring plate Wh 1 bar to 4 bar (F2)	LM	10 000 114
30	spring plate Wh 2 bar to 8 bar (F3)	LM	10 000 114
30	spring plate Wh 4 bar to 16 bar (F4)	LM	10 000 148
30	spring plate Wh 12 bar to 30 bar (F5)	LM	10 000 148
31	base plate	LM	10 020 908
32	cylinder bolt (setting retension)	St	00 010 351
33	cap	LM	10 010 430
34	seal wire	St	00 026 184
	seal	Pb	00 005 225

Parts marked with * should be kept in stock for maintenance purposes.

Material key:

St ... steel
 LM ... light alloy
 Pb ... lead

3. Special maintenance notice

Sealing ring (8)

- The plastic sealing rings must be renewed at each maintenance interval.

Piston (23)

- The capillary pipe used in the piston ensures the venting of the spring chamber; the capillary bore must therefore always remain unobstructed.

Measuring diaphragms (24)

- When installing the measuring diaphragm the setpoint spring (29) should be screwed into the spring housing (14) until the diaphragm clamp is at the same level as the outer clamp, i.e. level with the sleeve (27).

3.1 Torques

item no.	tightening torque M _A in Nm
1	25
7	4
32	25

3.2 Lubricants

component (brush thinly)	lubricant	part no.
all O rings, all moving parts	silicon grease	00 027 081
setpoint adjustment screw (17)	assembly paste	00 027 091
all fastening screws and pipe connections	heavy duty grease	00 027 058

For More Information

To learn more about Honeywell's
Advanced Gas Solutions, visit
www.honeywellprocess.com or contact
your Honeywell account manager

GERMANY**Honeywell Process Solutions**

Honeywell Gas Technologies GmbH

Osterholzstrasse 45

34123 Kassel, Germany

Tel: +49 (0)561 5007-0

Fax: +49 (0)561 5007-107

HON 832.20
2017-01
© 2017 Honeywell International Inc.

Honeywell