

OPERATING AND MAINTENANCE INSTRUCTIONS/
SPARE PARTS

EDITION 01/2017

**Serving the Gas Industry
Worldwide**

Honeywell

Table of contents		Page
1.	General information	3
1.1	General information	3
1.2	Safety information	3
1.3	Applications and features	4
1.4	Structure and mode of operation	4
2.	Specific operating instructions	5
2.1	High frequency radiation exposure	5
2.2	Stepper motor control card	5
3.	Technical features	5
3.1	Technical features of the mixer	5
3.2	Dimensions and technical features of the stepper motor	5
3.3	Technical features of the proximity sensor (limit switch)	6
3.4	Dimensional drawing HON 985A-100/50-ZW-N-NI	7
4.	Specific maintenance instructions	8
4.1	Intervals for maintenance instructions	8
4.2	Tightening torques MA	8
4.3	Lubricants	8
4.4	Adhesives	8
5.	Maintenance	9
5.1	Dismantling the proximity sensors	9
5.2	Dismantling the drive unit	9
5.3	Dismantling the Venturi insert	10
5.4	Replacing the guide belts	10
5.5	Installing the Venturi insert	10
5.6	Mounting the induction elbow	10
5.7	Mounting the drive unit	11
5.8	Adjusting the proximity sensors	11
6.	Spare parts	
6.1	Spare parts drawing HON 985A-100/50-ZW-N-NI	12
6.2	Spare parts list HON 985A-100/50-ZW-N-NI	13
6.3	Parts for maintenance purposes	15

1. General

1.1 General information

All persons involved with the assembly, operation and/or maintenance of the gas mixer HON 985A -100/50-ZW-N-NI must attentively read and understand these operating and maintenance instructions in their entirety.

Inspection and maintenance intervals depend mostly on the operating conditions at the respective system. Amongst other factors, the type of gas used and the corresponding gas composition, and the existing gas contamination as well as any accumulating condensates must be taken into account. There are no general rules or recommendations for intervals. Therefore, it is advisable to include the devices in the gas engine maintenance intervals.

Note

If operational irregularities are discovered during the operation or during a functional test, unplanned maintenance work on the mixer is required. This must be performed immediately after the discovery of the deviation in operating behaviour.



During maintenance, components must be cleaned and then checked thoroughly. This is necessary even if there have not been any unusual observations during operation and/or functional testing. The check must include in particular seals, all moving parts such as parts with transmission thread and the venturi insert. Any and all defective parts must be replaced with new ones. The same applies to o-rings removed during dismantling.

Do not use any spare/wear parts and/or oils & lubricants not specifically recommended in the Honeywell operating and maintenance instructions. In the event spare/wear parts and/or oils & lubricants other than those specifically recommended are used, Honeywell shall not be held liable for any defects and/or consecutive damages attributable to such use of illegal parts, lubricants, oils etc.

Some parts in the lists and drawings are marked with a letter "W". We recommend to always have a reserve of those parts in stock for maintenance purposes. Those spare parts are put together in a separate table at the end of the spare parts list.

1.2 Safety information

In this manual, safety information is highlighted by means of the following signal words and eye catchers:

Eye catcher	Used for:
 Danger	Danger to life and limb
 Caution	Danger of damage to property and/or the environment
Note	Important additional information

1.3 Applications and features

- **Application**

- Variable mixing of air and fuel gas for gas engines (e.g. for λ -control, electronic spark control, combustion-chamber temperature control)
- Mixing gases for operating gas motors with multiple types of fuel gas (e.g. sewage gas, secondary operation with natural gas)
- In general, mixing all sorts of gases (e.g. boosting low calorific-value gases e.g. waste dump gas)
- Applicable for natural gas, sewage gas, dump gas, mine gas, propane, butane and neutral gases

- **Features**

- Simple construction
- Instantaneous carburetion (Venturi effect)
- Adjustable fuel-gas mixing gap provides for flexible mixing ratios
- Fine adjustment of mixing ratios possible
- Sensitive stepper motors provide for precise adjustment of mixing gap
- Turbulent mixing (homogenization)

1.4 Structure and mode of operation

This gas mixer has been designed on the principle of the Venturi effect. There is a gas-pressure control system that brings gas 2 (fuel gas) flowing in through an upstream gas pressure control section to the same pressure as gas 1 (air). With the reduction of the cross-section, there is an acceleration of gas 1 (air) flowing in. Acceleration means the pressure of the gas goes down. The result is a pressure difference at the mixing gap. The pressure difference and the mixing gap, as adjusted, make sure that gas 2 (fuel gas) is mixed with gas 1 (air) proportionally (Venturi effect).

For the mixture of the gases, a torpedo designed for maximum flow rates of the gas mixture is integrated in the device. The downstream flow edges of the torpedo support the turbulent mixing of the two types of gases (homogenization). For a more precise adjustment of the mixing ratio (λ -control, for instance), there are sensitive electronic control loops and motors that can adjust the gap according to operational requirements.

Air / fuel gas mixture

Ratio	not rich enough	too rich
Precautions	increase the mixing gap	reduce the mixing gap

HON 985A-100/50-ZW-N-NI

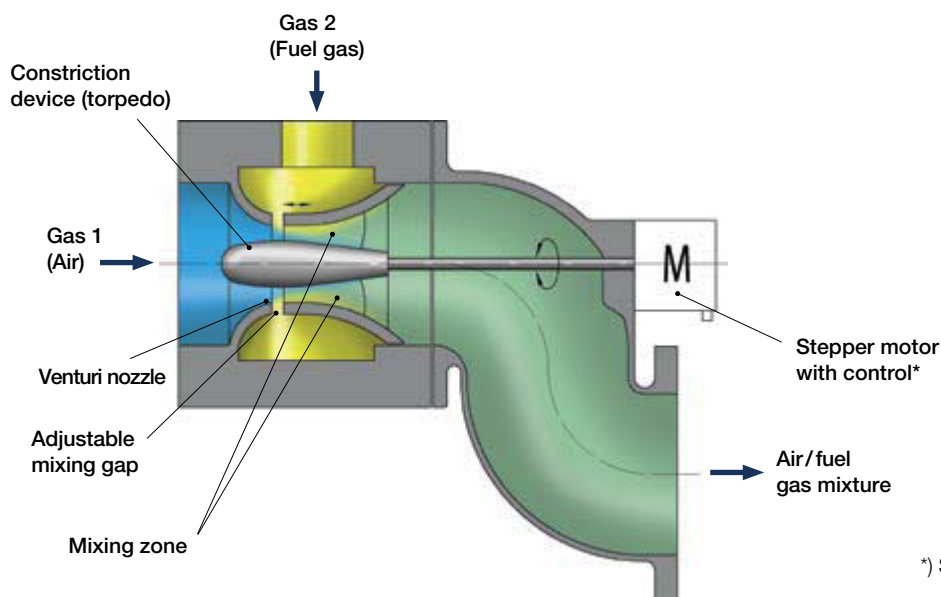

*) Stepper motor control, e.g. for
 – λ -control
 – Control of cylinder temperature
 – Electronic spark control

Fig 1: Functional principle

2. Specific operating instructions

2.1 High frequency radiation exposure (comment on application at gas engine)

Note

Possible faults due to high frequency radiation exposure (e.g. from the coil and its cable) must be prevented for the proper response of the proximity sensors and stepper motor, e.g. by routing the cables separately.

2.2 Stepper motor control card

A stepper motor control card is not included in the scope of delivery. When choosing a stepper motor control card, the following data for the stepper motor and the proximity sensors should be taken into account.

3. Technical data

3.1 Technical features of the mixer

Table 1: Technical features of the mixer

Max. permissible pressure load PS	0.5 bar
Mixing ratio Qn air/Qn fuel gas	3.5 : 1 to 25 : 1
Materials	Body: Aluminium alloy Internal parts: Al alloy/steel Seals: NBR
Max. operating and environmental temperature	-10 °C to +80 °C
SEP design in accordance with PED	

3.2 Dimensions and technical features of the stepper motor

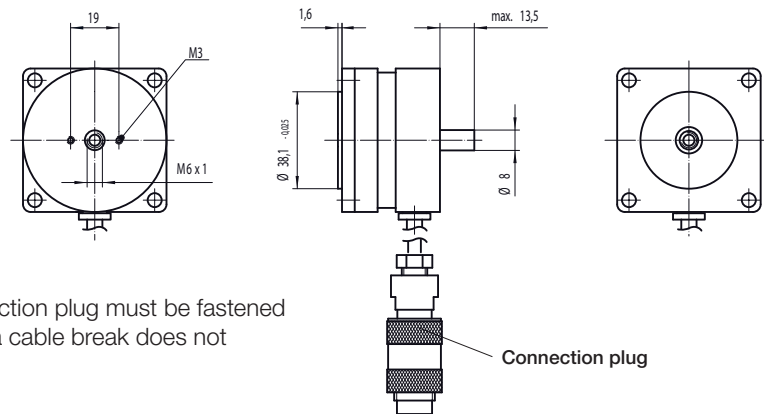

Cable and connection plug must be fastened properly so that a cable break does not occur.

Fig 2: Dimensional drawing of the stepper motor

Table 2: Technical features of the stepper motor

Design	Hybrid stepper motor
Coil type	Bipolar, parallel switching
Rotor moment of inertia	60 gcm ²
Holding torque	28.5 Ncm
Full steps per shaft rotation	200
Step angle (full step)	1.8 °
Resistance per coil	1.3 Ω
Max. current per phase	2 A
Inductivity per coil	2.8 mH
Length of the electrical supply line	approx. 0.3 m
Electrical connection	5-pin round plug and socket

Note

A socket compatible with the stepper motor is included in the delivery.

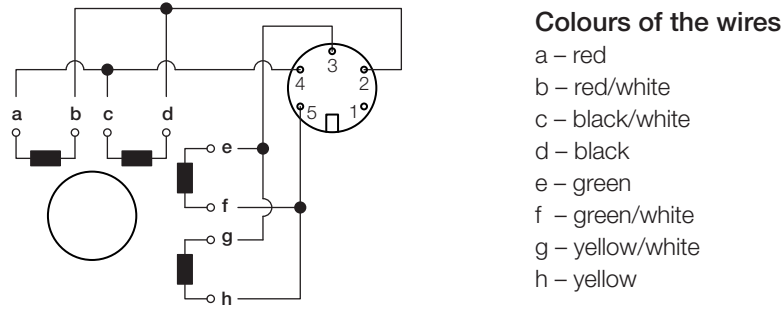

Fig 3: Connection diagram of the stepper motor

3.3 Technical features of the proximity sensor (limit switch) for Venturi position

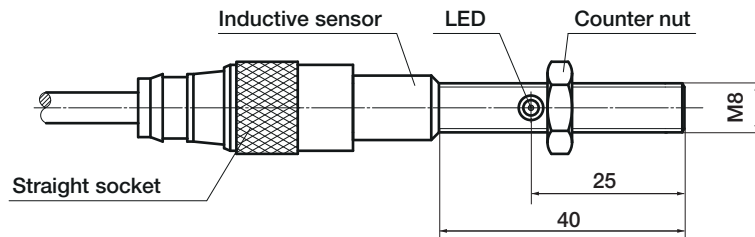

Fig 4: Proximity sensor

Table 3: Technical features of the proximity sensor

Connection	V1 device plug
Operating voltage	10 – 60 VDC
Ripple	≤ 10 %
Switching frequency	500 Hz
Operating current	100 mA
Idling power consumption	15mA
Output marking	ppn opener (positive switched)
Active surface free	Operating voltage – (max. 3 V at 100 mA)
Active surface covered	≤ 0.3 V
Interference voltage (permissible voltage peaks)	max. 1,000 V / 10 ms
Internal resistance	10 kΩ
Switching status LED	yellow light when active surface is free
Adjusting and counter nut	SW 13

Note

A straight socket compatible with the proximity sensor is included in the delivery.

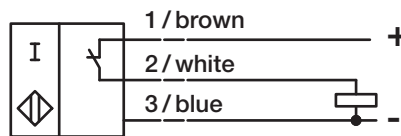
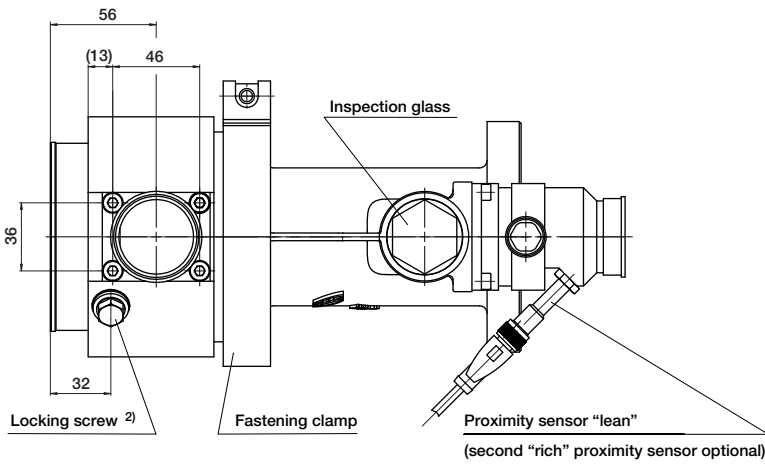
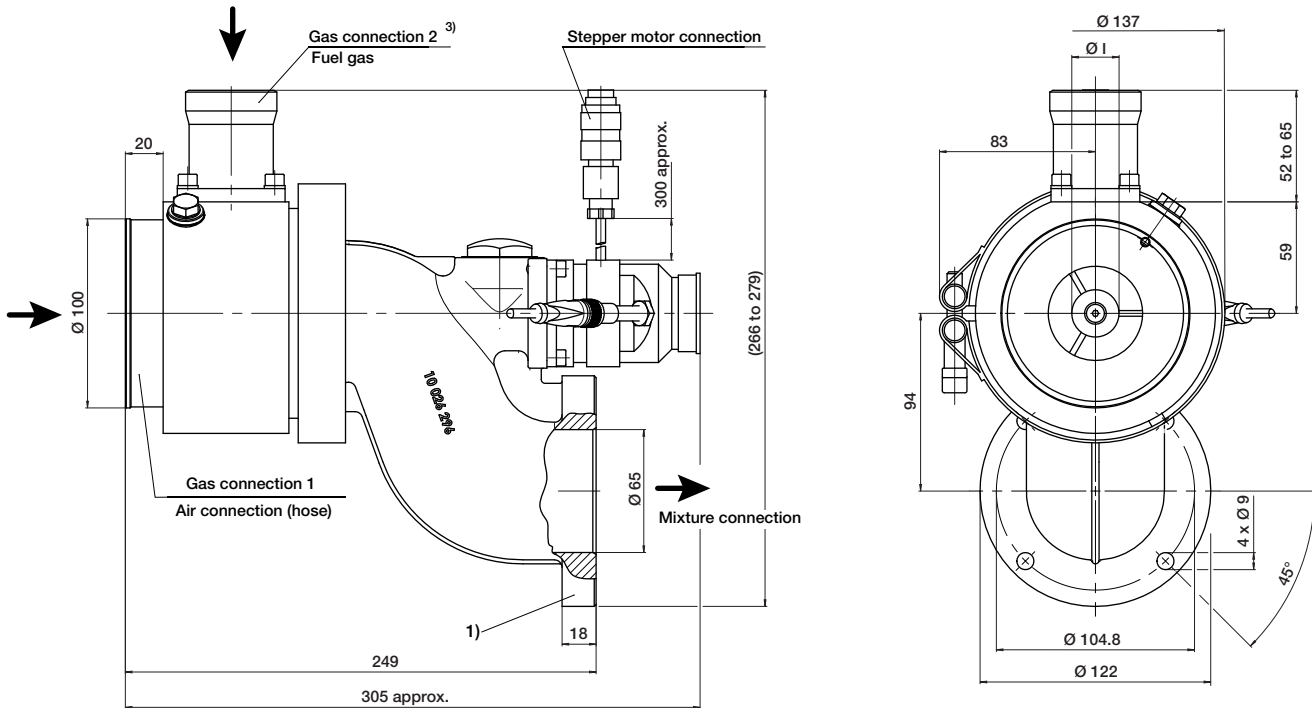

Fig 5: Proximity sensor connection diagram

3.4 Dimensional drawing HON 985A-100/50-ZW-N-NI



Comments:

- ➔ Flow direction
- Ø1 Variable torpedo diameter (see spare parts list)
- 1) Induction elbow can be installed at any angle position in relation to the driving axle
- 2) Pressure measurement M14 x 1.5 connection possibility
- 3) Variable fuel gas connection (for dimensions and type, see below)

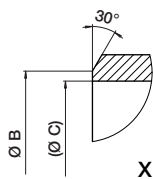
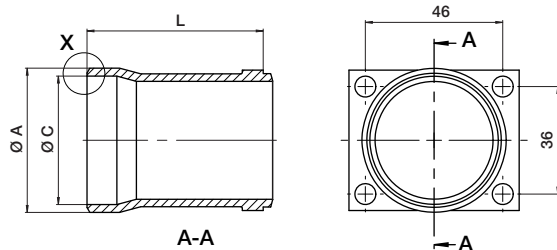

Flange type	Ø A	Ø B	Ø C	L
Type 1	44.5	41	39.5	64
Type 2	48.3	45	43	52
Type 3	48.3	45	43	59
Type 4	G1 A (Rp 1)	-	34	65

Fig 6: Mixer and gas connection dimensional drawing

4. Specific maintenance instructions



Do not carry out maintenance unless the system is safely de-energised and depressurised.

4.1 Intervals for maintenance purposes

The intervals between maintenance tasks depend largely on the operating conditions of the device. For this purpose, please observe chapter **1.1. General Information**.

Note

If operational irregularities are discovered during the operation or during functional tests, unplanned maintenance work on the mixer is required. This must be performed immediately after the discovery of the deviation in operating behaviour.

4.2 Tightening torques M_A

Screws and nuts without a specification of the tightening torques are tightened according to the commonly available tables for screw dimensions and qualities using an appropriate tool. Parts with an explicitly specified tightening torque (see spare parts drawing) are to be tightened to the specified value with a torque wrench (see Table 4).

Table 4: Tightening torques M_A

Pos. no.	112	120	123	132
Tightening torque in Nm	8	2.8	12	212

4.3. Lubricants

All O-rings which are replaced (see **1.1 General information**) must be lubricated with silicone grease before installation after the device maintenance.



Observe the notes regarding lubricants in chapter **1.1 General information**.

Table 5: Lubricants

Components	Lubricants	HON part no.
All O-rings	Silicone grease	27081
All fastening screws	Assembly paste	27091
Transmission thread and conical washer on the threaded rod	Slip agent	27704

4.4 Adhesives

The parts to be glued must be completely clean, dry and free of grease. Specifications for adhesive connections can be found in the spare parts drawing and the following maintenance instructions.

Table 6: Adhesives

Adhesive connections	Adhesive	HON part no.
Rod	Anaerobic adhesive	26690
Rod thread	Anaerobic adhesive	26690

5. Maintenance

With the description of the individual maintenance steps, the same position numbers are used here for the identification of the component as can be found in the spare parts drawing (page 12) and the spare parts list (page 13 and 14).

For simple, easy maintenance work, we recommend following the sequence of the individual steps. The device must be dismantled from the plant prior to maintenance work.

5.1 Dismantling the proximity sensors



Caution

Prior to the dismantling of the drive unit of the mixer and the maintenance work, we strongly recommend removing the proximity sensors (117) from the device in order to prevent damage. Prior to their removal, the proximity sensors should be disconnected from the power source. Unscrew the cable sockets (118) from the proximity sensors. Loosen the counter nuts and unscrew the proximity sensors from the receptacle (115).

5.2 Dismantling the drive unit

Remove the cap (121), unscrew the hexagon nut (120) and remove the washer (119) from the threaded rod (111). Unscrew both cylinder screws (116) located behind the conical washer (119) and remove the receptacle (115). By turning the motor spindle (Figure 7), the venturi insert (101) is first pushed to the mechanical stop on the mixer body (130) and then unscrewed from the threaded rod with additional rotation of spindle of the stepper motor (113).



Fig 7: Rotation direction of the motor spindle with removal of the drive unit

The next step is the removal of the threaded rod (111) from the device. For this purpose, unscrew the inspection glass (109) from the induction elbow (133) and loosen the clamp connection between the threaded rod and the pin (105) by loosening the threaded pin (110).

The threaded rod is an assembly including the following individual parts: Rod thread M6, rod thread M4 and fixing washer (see Figure 8 and Table 6) are adhered together. Check that all adhesive connections are firmly seated.

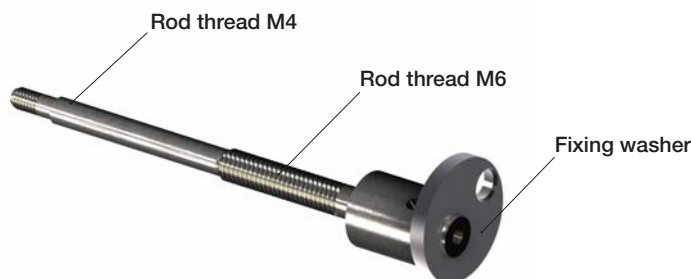

Fig 8: Threaded rod assembly (111)

Then carefully clean and dry all dismantled parts. Check the condition of the transmission thread (motor spindle interior and threaded rod exterior (111)).

Lightly spray the transmission thread (M6) on the threaded rod and the contact surfaces on the outer diameter of the washer (119) with slip agent (Table 5). The recommended coating thickness is 5 – 15 µm. Shake slip agent spray can well before use. We recommend coating the threaded surfaces in a crossing pattern. Allow sprayed surfaces to dry for 5 – 7 minutes at room temperature.

5.3 Dismantling the Venturi insert

Loosen the cylinder screw on the profile clip (132) and remove it. Separate the induction elbow (133) from the mixer body (130).



Carefully separate the parts from one another in order to prevent damage to the pin (105) by bending, etc.

Now the Venturi insert with the pin and torpedo unit (126) (Figure 9) can be pulled out of the mixer body.

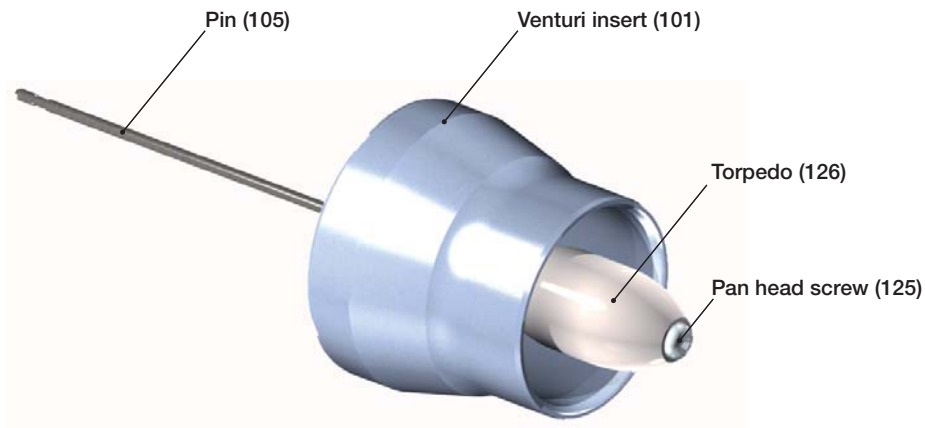

Fig 9: Unit with venturi insert and pin

The torpedo unit (126) is dismantled after unscrewing the pan head screw (125). The venturi insert (101) and the pin are adhered to one another and may not be separated from one another. If the parts can be easily separated by hand, the assembly must be repaired (adhered) or replaced. Clean and dry off the dismantled parts.

5.4 Replacing the guide belts

The next step is the removal of the guide body (102) from the mixer body (130). Remove and dispose of the used guide belts (129 and 131). Carefully clean the sliding surfaces on the venturi insert (101) and groove for the guide belts with adjacent surfaces and allow to dry. Fit new guide belts.



The guide belts (129 and 131) and sliding surfaces may not be lubricated. The lubrication of the parts can negatively influence the operating behaviour of the device.

5.5 Installing the venturi insert

Move the mixer body (130) up to the vertical position with the connection side facing the induction elbow (133). Mount the torpedo unit (126) on the venturi insert (101). In the process, the pan head screw must be secured with low-strength thread locker (e.g. LOCTITE 221). Slide the guide body (102) into the mixer body up to the mechanical stop. Insert the venturi insert with the small diameter forward into the guide body and check the ease of movement of the venturi insert.

If it is difficult to push the venturi insert in, the guide belts (129 and 131) must be adjusted by removing a thin layer, however, only to the extent that the venturi insert does not fall through under the force of its own weight. Otherwise, the play between the venturi insert and the guide belts is too great.

5.6 Mounting the induction elbow

After the adjustment of the guide belts (129 and 131), the induction elbow (133) is mounted on the mixer body (130). The mixer body remains vertically aligned. Prior to mounting the induction elbow, make sure that the O-ring (104) is greased and does not twist out of the groove. Carefully place the elbow on the mixer body so that the pin (105) goes in through the hole in the induction elbow provided for this purpose. Place the profile clip (132) on the angles of the two flanges (on the housing and the induction elbow) and connect the two parts in the correct spatial arrangement by tightening the cylinder screw. Observe the tightening torques in Table 4 (page 8).

5.7 Mounting the drive unit

With moderate pressure on the pin (105), push the venturi insert (101) into the vertically positioned mixer body (130) up to the mechanical stop. Then place the threaded rod (111) on the end of the pin up to the mechanical stop. In the process, it must be ensured that the threaded rod is positioned over its hole in the fixing washer of the cylinder pin (134). By tightening the threaded pin (110), the pin is fixed in the hold. Secure the threaded pin with a low-strength thread locker (e.g. LOCTITE 221).

Place the stepper motor (113) on the threaded pin and screw it on by rotating the stepper motor spindle up to the mechanical stop on the flange of the induction elbow (133). Fasten the stepper motor on the induction elbow with four cylinder screws (112); in the process, observe the tightening torque for the screws (Table 4).

Place the receptacle (115) on the stepper motor spindle and align it to the desired side with the sensor fastening thread (alignment in the direction of the output flange of the induction elbow is not possible due to the spatial constraints), and install the cylinder screws (116).

Slide the washer (119) on as shown under **6.1** until the mechanical stop of the threaded rod is reached and fasten with an M6 hexagon nut (120). Observe the tightening torque (Table 4, page 8).

Then fit the cap (121) and screw in the inspection glass (109) with seal in the induction elbow.

5.8 Adjusting the proximity sensors (limit switches)

Connect the stepper motor (113) of the mixer to the stepper motor control.

Adjust a mixing gap of $0.5 + 0.1$ mm by moving the stepper motor. An adjustment of 0.5 mm takes place with a control frequency of 20 Hz in full step operation in 5 seconds.

Note

With a change to the control frequency by a factor K, the adjusting time changes by the factor $1/K$.

With a change to the step precision by a factor $1/F$, the adjusting time changes by the factor F.
With an adjustment of both parameters, factors F and $1/K$ are multiplied.

Adjust the switching point of the "lean" position by screwing in the proximity sensor (117). Screw in the proximity sensor until the LED on the sensor goes out. Then lock the proximity sensor in its position by tightening the counter nut. Observe the tightening torque according to section **6.1 Spare parts drawing**.

If the device is equipped with two sensors, the switching point for the "rich" position is adjusted first (max. mixing gap width). For this purpose, increase the mixing gap an additional 4.5 mm from the "lean" switching point by moving the stepper motor (total gap width $5 + 0.1$ mm). In full step operation the additional adjustment at a 60 Hz step frequency takes place in 15 seconds. Observe the notice above.

The adjustment of the screw-in position of the proximity sensor, "rich" switching point, takes place analogously to the adjustment of the "lean" switching point. Then lock the sensor in place here as well by tightening the counter nut.

6 Spare parts

6.1 Spare Parts Drawing HON 985A -100/ 50-ZW-N-NI

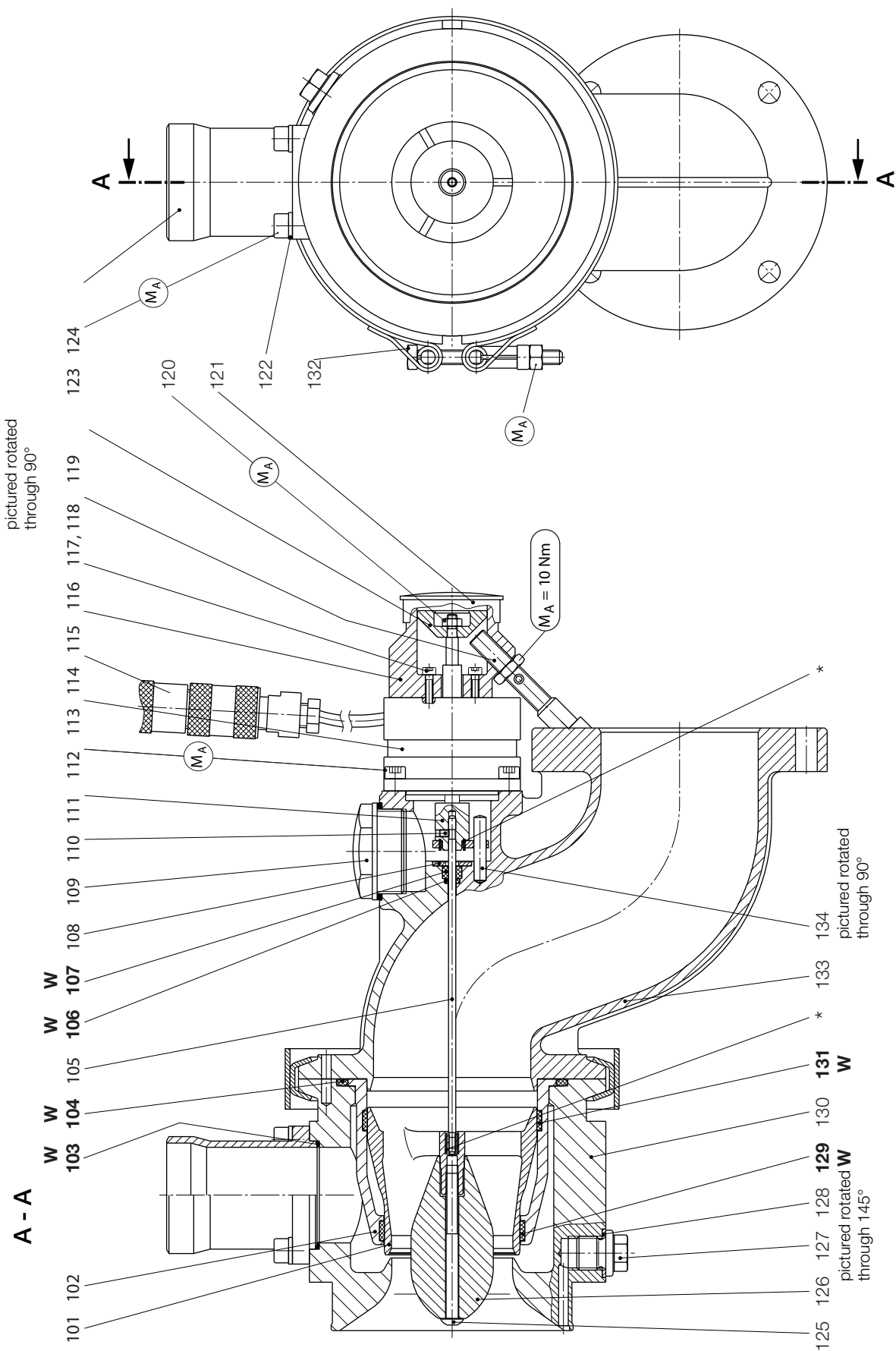

M_A Be sure to comply with torque figures in table 4 on page 8!

W Parts should be held in stock for maintenance purposes

* Use adhesive connection in accordance with table 6, page 8

6.2 Spare parts list HON 985A-100/50-ZW-N-NI

Item no.	Denomination	Number	W	Material	Part no.
101	Venturi insert	1		LM	10026263
102	Guide body	1		LM	10026262
103	O-Ring	1	W	KG	20706
104	O-Ring	1	W	KG	20257
105	Pin	1		NSt	10026264
106	O-Ring	1	W	KG	21096
107	Sliding contact bearing	1	W	K	28231
108	Washer	1		St	10004881
109	Inspection glass	1		K	27280
110	Threaded pin	1		St	12405
111	Threaded rod, complete	1		NSt	10026281
112	Cylinder screw	4		St	10318
113	Stepper motor linear actuator	1		LM/Bz	24534
114	Socket	1		K	24107
115	Receptacle, sensor	1		LM	10026287
116	Cylinder screw	2		St	10658
117	Proximity sensor	1		NSt	24122
118	Socket	1		K	24123
119	Washer, cone	1		LM	10026289
120	Hexagon nut	1		St	5414
121	Cap	1		K	26070
122	Washer	4		St	14156
123	Cylinder screw	4		St	10320
124	Flange DN 40, alternatively:				
124	Flange type 1	1		St	10020735
124	Flange type 2	1		St	10020734
124	Flange type 3	1		St	10020733
124	Flange type 4	1		St	10020827
125	Pan head screw	1		NSt	10659

W Parts should be held in stock for maintenance purposes

German abbreviations stand for the following materials:

St ... Steel	LM ... Light metal	GMs ... Cast brass
NSt ... Stainless steel	Ms ... Brass	GZn ... Cast zinc
FSt ... Spring steel	GS ... Cast steel	AlBz ... Aluminium bronze
NFSt ... Stainless spring steel	GGG ... Spheroidal graphite cast iron	K ... Plastic
Bz ... Bronze	GBz ... Cast bronze	KG ... Gummous synthetic materials
Cu ... Copper	GLM ... Cast light metal	SSt ... Foamed materials

Item no.	Denomination	Number	W	Materials	Part no.
126	Torpedo, optional:				
126	Torpedo ø 18	1		K	10026275
126	Torpedo ø 25	1		K	10031549
126	Torpedo ø 30	1		K	10030496
126	Torpedo ø 33	1		K	10031550
126	Torpedo ø 36	1		K	10030497
127	Locking screw	1		St	26175
128	Seal ring	1		LM	18842
129	Guide belt	1	W	K	10026256
130	Mixer body	1		LM	10026261
131	Guide belt	1	W	K	10026257
132	Profile clip	1		NSt	28227
133	Induction elbow	1		GLM	10026297
134	Cylinder pin	1		St	17277

6.3 Parts for maintenance purposes

Item no.	Denomination	Number	Part no.
103	O-Ring	1	20706
104	O-Ring	1	20257
106	O-Ring	1	21096
107	Sliding contact bearing	1	28231
129	Guide belt	1	10026256
131	Guide belt	1	10026257
	Thread locker	1	26688
	Silicone grease	1	27081
	Assembly paste	1	27091
	Slip agent	1	27704
	Adhesive	1	26690

For More Information

To learn more about Honeywell's
Advanced Gas Solutions, visit
www.honeywellprocess.com or contact
your Honeywell account manager

GERMANY**Honeywell Process Solutions**

Honeywell Gas Technologies GmbH

Osterholzstrasse 45

34123 Kassel, Germany

Tel: +49 (0)561 5007-0

Fax: +49 (0)561 5007-107

HON 985.29_2
2017-01

© 2017 Honeywell International Inc.

The Honeywell logo is displayed in a bold, red, sans-serif font.