

OPERATING AND MAINTENANCE INSTRUCTIONS/
SPARE PARTS

EDITION 01/2017

**Serving the Gas Industry
Worldwide**

Honeywell

Table of contents

Page

1.	General	3
1.1	General information	3
1.2	Safety information	3
1.3	Applications and features	4
1.4	Structure and mode of operation	4
2.	Specific operating instructions	5
2.1	High frequency radiation exposure	5
2.2	Stepper motor control card	5
3.	Technical data	5
3.1	Technical features of the mixer	5
3.2	Dimensions and technical features of the stepper motor	5
3.3	Technical features of the proximity sensor (limit switch)	6
3.4	Dimensional drawing HON 985B-70/35-ZW-N-NI	7
4.	Specific maintenance instructions	8
4.1	Intervals for maintenance instructions	8
4.2	Tightening torques M_A	8
4.3	Lubricants	8
4.4	Adhesives	8
5.	Maintenance	9
5.1	Dismantling the proximity sensors	9
5.2	Dismantling the drive unit	9
5.3	Dismantling the Venturi insert	9
5.4	Replacing the guide belts	10
5.5	Installing the Venturi insert	10
5.6	Mounting the induction elbow	10
5.7	Mounting the drive unit	10
5.8	Adjusting the proximity sensors	11
6.	Spare parts	12
6.1	Spare parts drawing HON 985B-70/35-ZW-N-NI	12
6.2	Spare parts list HON 985B-70/35-ZW-N-NI	13
6.3	Parts for maintenance purposes	14

1. General

1.1 General information

All persons involved with the assembly, operation and/or maintenance of the gas mixer HON 985A -70/35-ZW-N-NI must attentively read and understand these operating and maintenance instructions in their entirety.

Inspection and maintenance intervals depend heavily on the operating conditions at the respective system. Amongst other factors, the device used and the corresponding gas composition, and the existing gas contamination as well as any accumulating condensates must be taken into account. There are no general rules or recommendations for intervals. Therefore, it is advisable to include the devices in the gas engine maintenance intervals.

Note

If operational irregularities are discovered during the operation or during a functional test, unplanned maintenance work on the mixer is required. This must be performed immediately after the discovery of the deviation in operating behaviour.



During maintenance, components must be cleaned and then checked thoroughly. This is necessary even if there have not been any unusual observations during operation and/or functional testing. The check must include in particular seals, all moving parts such as parts with transmission thread and the venturi insert. Any and all defective parts must be replaced with new ones. The same applies to O rings removed during disassembly.

Do not use any spare/wear parts and/or oils & lubricants not specifically recommended in the Honeywell operating and maintenance instructions. In the event spare/wear parts and/or oils & lubricants other than those specifically recommended are used, Honeywell shall not be held liable for any defects and/or consecutive damages attributable to such use of illegal parts, lubricants, oils etc.

Some parts in the lists and drawings are marked with a letter "W" . We recommend to always have a reserve of those parts in stock for maintenance purposes. Those spare parts are put together in a separate table at the end of the spare parts list.

1.2 Safety information

In this manual, safety information is highlighted by means of the following signal words and eye catchers:

Eye catcher	Used for:
 Danger	Danger to life and limb
 Caution	Danger of damage to property and/or the environment
Note	Important additional information

1.3 Applications and features

- **Application**

- Variable mixing of air and fuel gas for gas engines (e.g. for λ -control, electronic spark control, combustion-chamber temperature control)
- Mixing gases for operating gas motors with multiple types of fuel gas (e.g. sewage gas, secondary operation with natural gas)
- In general, mixing all sorts of gases (e.g. boosting low calorific-value gases e.g. waste dump gas)
- Applicable for natural gas, sewage gas, dump gas, mine gas, propane, butane and neutral gases

- **Features**

- Simple construction
- Instantaneous carburetion (Venturi effect)
- Adjustable fuel-gas mixing gap provides for flexible mixing ratios
- Fine adjustment of mixing ratios possible
- Sensitive stepper motors provide for precise adjustment of mixing gap
- Turbulent mixing (homogenization)

1.4 Structure and mode of operation

This gas mixer has been designed on the principle of the Venturi effect. There is a gas-pressure control system that brings gas 2 (fuel gas) flowing in through an upstream gas pressure control section to the same pressure as gas 1 (air). With the reduction of the cross-section, there is an acceleration of gas 1 (air) flowing in. Acceleration means the pressure of the gas goes down. The result is a pressure difference at the mixing gap. Through the pressure difference and the mixing gap, as adjusted, make sure that gas 2 (fuel gas) is mixed with gas 1 (air) proportionally (Venturi effect).

For the mixture of the gases, a torpedo designed for maximum flow rates of the gas mixture is integrated in the device.

The downstream flow edges of the torpedo support the turbulent mixing of the two types of gases (homogenization).

For a more precise adjustment of the mixing ratio (λ -control, for instance), there are sensitive electronic control loops and motors that can adjust the gap according to operational requirements.

Air/fuel gas mixture

Ratio	not rich enough	too rich
Precautions	increase the mixing gap	reduce the mixing gap

HON 985B-70/35-ZW-N-NI

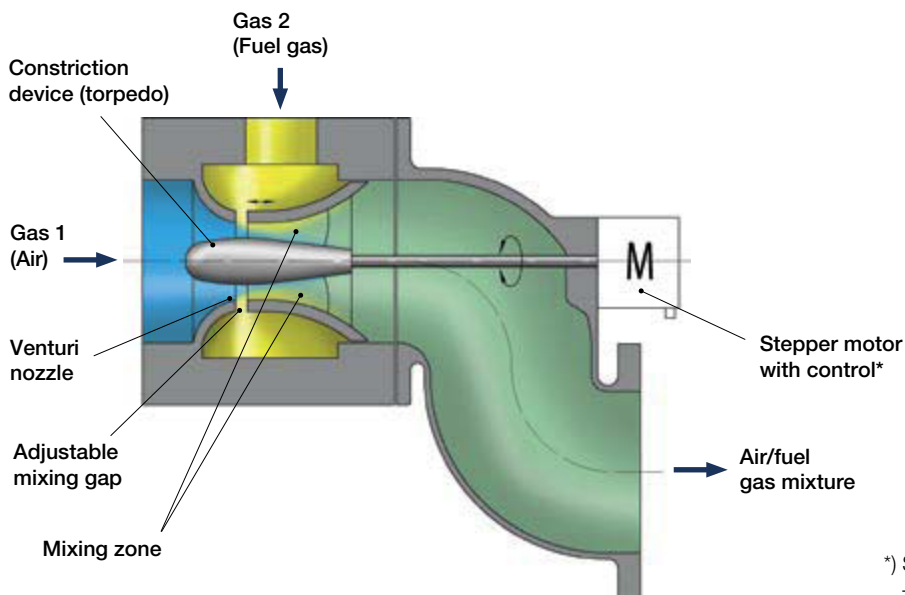

*) Stepper motor control, e.g. for
 – λ -control
 – Control of cylinder temperature
 – Electronic spark control

Fig 1: Functional principle

2. Specific operating instructions

2.1 High frequency radiation exposure (comment on application at gas engine)

Note

Possible faults due to high frequency radiation exposure (e.g. from the coil and its cable) must be prevented for the proper response of the proximity sensors and stepper motor, e.g. by routing the cables separately.

2.2 Stepper motor control card

A stepper motor control card is not included in the scope of delivery. When choosing a stepper motor control card, the following data for the stepper motor and the proximity sensors should be taken into account.

3. Technical data

3.1 Technical features of the mixer

Table 1: Technical features of the mixer

Max. permissible pressure load PS	0.5 bar	
Mixing ratio Qn air/Qn fuel gas	3.5 : 1 to 25 : 1	
Materials	Body: Internal parts: Seals:	Aluminium alloy Al alloy/steel NBR
Max. operating and environmental temperature	-10 °C to +80 °C	
SEP design in accordance with PED		

3.2 Dimensions and technical features of the stepper motor

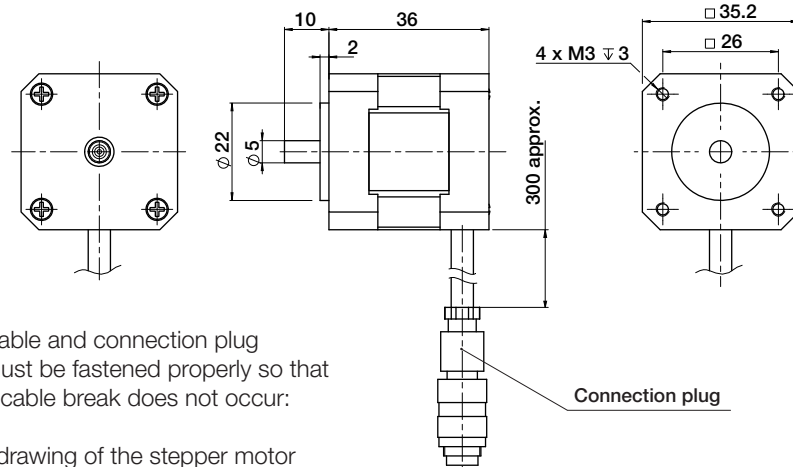

Cable and connection plug must be fastened properly so that a cable break does not occur:

Fig 2: Dimensional drawing of the stepper motor

Table 2: Technical features of the stepper motor

Design	Hybrid stepper motor
Coil type	Bipolar, switched in series
Rotor moment of inertia	14 gcm ²
Holding torque	14 Ncm
Full steps per shaft rotation	200
Step angle (full step)	1.8 °
Resistance per coil	2.7 Ω
Max. current per phase	1 A
Inductivity per coil	4.3 mH
Length of the electrical supply line	Approx. 0.3 m
Electrical connection	5-pin round plug and socket

Note

A socket compatible with the stepper motor is included in the delivery.

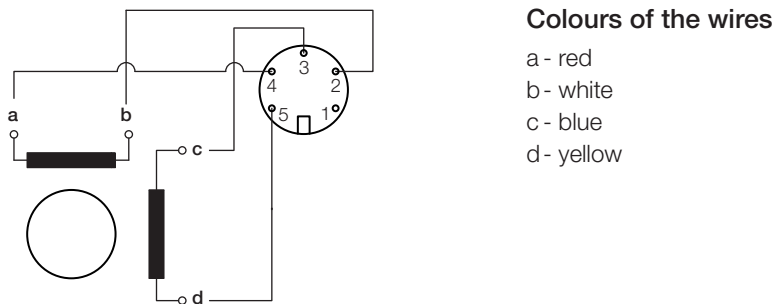

Fig 3: Connection diagram of the stepper motor

3.3 Technical features of the proximity sensor (limit switch) for venturi position

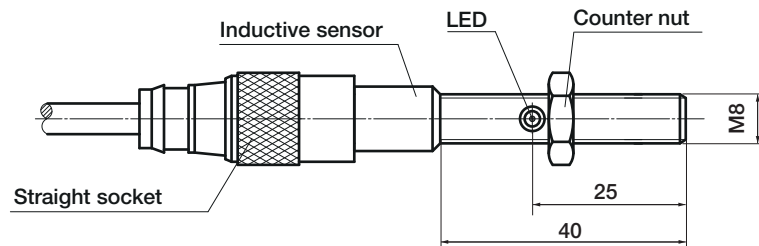

Fig 4: Proximity sensor

Table 3: Technical features of the proximity sensor

Connection	V1 device plug
Operating voltage	10–60 VDC
Ripple	≤ 10 %
Switching frequency	500 Hz
Operating current	100 mA
Idling power consumption	15 mA
Output marking	ppn opener (positive switched)
Active surface free	Operating voltage – (max. 3 V at 100 mA)
Active surface covered	≤ 0.3 V
Interference voltage (permissible voltage peaks)	Max. 1,000 V/10 ms
Internal resistance	10 kΩ
Switching status LED	Yellow light when active surface is free
Adjusting and counter nut	SW 13

Note

A straight socket compatible with the proximity sensor is included in the delivery.

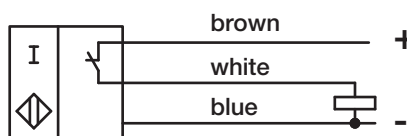

Fig 5: Proximity sensor connection diagram

4. Specific maintenance instructions



Do not carry out maintenance unless the system is safely de-energised and depressurised.

4.1 Intervals for maintenance purposes

The intervals between maintenance tasks depend largely on the operating conditions of the device. For this purpose, please observe chapter **1.1. General Information**.

Note

If operational irregularities are discovered during the operation or during functional tests, unplanned maintenance work on the mixer is required. This must be performed immediately after the discovery of the deviation in operating behaviour.

4.2 Tightening torques M_A

Screws and nuts without specification of the tightening torques are tightened according to the commonly available tables for screw dimensions and qualities using an appropriate tool. Parts with an explicitly specified tightening torque (see spare parts drawing) are to be tightened to the specified value with a torque wrench (see Table 4).

Table 4: Tightening torques M_A

Pos. no.	19
Tightening torque in Nm	8.5

4.3 Lubricants

All O-rings which are replaced (see **1.1 General information**) must be lubricated with silicone grease before installation after the device maintenance.



Observe the notes regarding lubricants in chapter **1.1 General information**.

Table 5: Lubricants

Components	Lubricants	HON part no.
All O-rings	Silicone grease	27081
All fastening screws	Assembly paste	27091
Transmission thread on the pin (21)	Slip agent	27704

4.4 Adhesives

The parts to be glued must be completely clean, dry and free of grease. Specifications for adhesive connections can be found in the spare parts drawing and the following maintenance instructions.

Table 6: Adhesives

Adhesive connections	Adhesive	HON part no.
Pin (21)	Anaerobic adhesive	26690

5. Maintenance

With the description of the individual maintenance steps, the same position numbers are used here for the identification of the component as can be found in the spare parts drawing (page 12) and the spare parts list (page 13).

In order to avoid problems during the maintenance work, we recommend following the sequence of the individual steps. The device must be dismantled from the plant prior to maintenance work.

5.1 Dismantling the proximity sensors



Caution

Prior to the dismantling of the drive unit of the mixer and prior to the maintenance work, we strongly recommend removing the proximity sensors (13) from the device in order to prevent damage.

Prior to their removal, the proximity sensors should be disconnected from the power source.

Unscrew the cable sockets (14) from the proximity sensors. Loosen the counter nuts and unscrew the proximity sensors from the mixer body (1).

5.2 Dismantling the drive unit



Danger

In this part of the maintenance work the stepper motor (10) must be supplied with electrical voltage (external). The maintenance work with electrical voltage must be performed outside of the Ex zone.

Unscrew four cylinder screws (8). Connect the stepper motor to the stepper motor control and move the venturi insert (4) to its mechanical stop in the mixer body (1) by moving the stepper motor in the “lean” direction (mixing gap becomes smaller). Unscrew the stepper motor with adjustable coupling (6) (Figure 7) by moving it further in the “lean” direction of the pin (21) while securing the stepper motor against rotating.

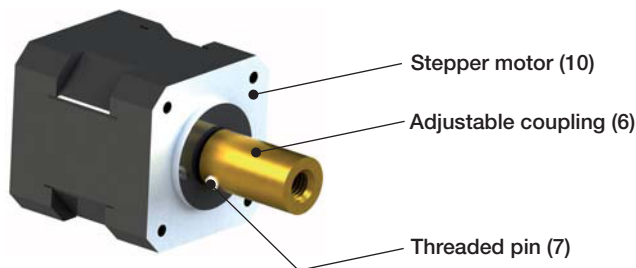

Fig 7: Stepper motor with adjustable coupling

Disassemble the adjustable coupling (6) from the shaft of the stepper motor (10). For this purpose, the threaded pin (7) (Figure 7) is loosened. Then carefully clean and dry all dismantled parts. Check the condition of the transmission thread of the adjustable coupling.

Lightly spray the transmission thread (M6) on the adjusting pin (21) with slip agent (Table 5). The recommended coating thickness is 5–15 µm. Shake slip agent spray can well before use. We recommend coating the threaded surfaces in a crossing pattern. Allow sprayed surfaces to dry for 5–7 minutes at room temperature.

5.3 Dismantling the venturi insert

Before the venturi insert (4) is removed from the device, the induction elbow (20) must be disconnected from the mixer body (1). For this purpose, unscrew the four cylinder screws (19) and disassemble the induction elbow.



Caution

Carefully separate the parts from one another in order to prevent damage to the transmission thread on the adjusting pin (21) and the adjusting pin itself as a result of bending, etc.

Then unscrew the inspection glass (15) from the mixer body. Unscrew the cylinder screw (16) and remove it from the mixer body together with the bush (17). Check the bush for wear and replace it if there is significant wear. Now the venturi insert with the pin and torpedo unit (Figure 8) can be pulled out of the mixer body.

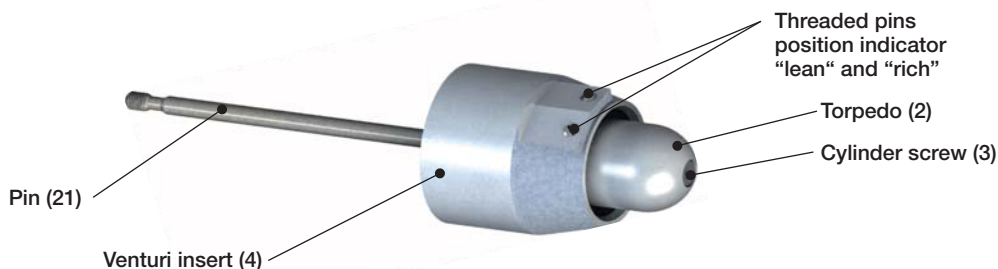

Fig 8: Venturi insert unit with adjusting pin and torpedo

The torpedo unit (2) is dismantled after unscrewing the cylinder screw (3). The venturi insert (4) and the pin (21) are adhered to one another and may not be separated from one another. If the parts can be easily separated by hand, the assembly must be repaired (adhered) or replaced. Clean and dry off the dismantled parts.

5.4 Replacing the guide belts

Now the used guide belts (18) must be removed from the mixer body (1) and disposed of. Carefully clean the sliding surfaces on the venturi insert (4) and groove for the guide belts with adjacent surfaces and allow to dry. Fit new guide belts.



The guide belts (18) and sliding surfaces may not be lubricated. The lubrication of the parts can negatively influence the operating behaviour of the device.

5.5 Installing the venturi insert

Move the mixer body (1) up to the vertical position (connection side facing up towards the induction elbow (20)). Mount the torpedo unit (2) on the venturi insert (4). In the process, the cylinder screw (3) must be secured with low-strength thread locker (e.g. LOCTITE 221). Insert the venturi insert with the small diameter forward into the mixer body and check the ease of movement of the venturi insert.

If it is difficult to push the venturi insert in, the guide belts (18) must be adjusted by removing a thin layer, however, only to the extent that the venturi insert does not fall through under the force of its own weight. Otherwise, the play between the venturi insert and the guide belts is too great.

5.6 Mounting the induction elbow

After the adjustment of the guide belts (18), the induction elbow (20) is mounted on the mixer body (1). The mixer body remains vertically aligned. Carefully place the elbow on the mixer body so that the pin (21) is inserted through the hole in the induction elbow provided for this purpose. Position the induction elbow using the holes in its flange and the two cylinder pins (5) in the mixer body and then fasten with the four cylinder screws (19). Observe the tightening torques in Table 4 (page 8).

5.7 Mounting the drive unit

Now the stepper motor (10) is fit together with the adjustable coupling (6). Slide the adjustable coupling with the \varnothing 5 mm hole on the shaft of the stepper motor and adjust the distance to approx. 1 mm to the stepper motor flange (see Figure 9).

Fix the position of the adjustable coupling on the shaft of the stepper motor by tightening the threaded pin (7). Secure the threaded pin with a low-strength thread locker (e.g. LOCTITE 221).



Observe the adjustment measurement!

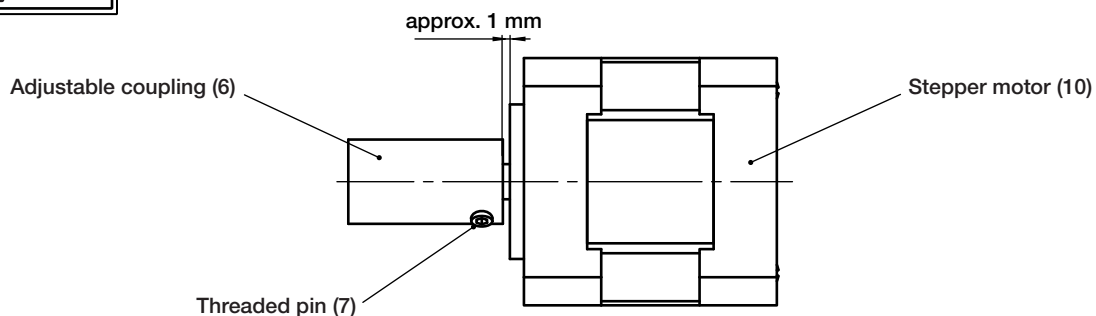

Fig 9: Adjustable coupling to stepper motor flange adjustment measurement

Now slide the venturi insert (4) to the mechanical stop of the mixer body (1) by applying moderate pressure on the pin (21). Screw the cylinder screw (16) with fitted bush (17) into the threaded hole in the venturi insert provided for this purpose and tighten (appropriately align the venturi insert beforehand).

In doing so, the venturi insert is secured against rotating in the mixer body.

Afterwards place the stepper motor (10) with fitted adjustable coupling (6) on the thread of the pin (21).

Then actuate the stepper motor control so that the shaft rotates anti-clockwise (as viewed from the stepper motor flange). In the process, hold the stepper motor to secure it against rotating. Now the stepper motor screws onto the pin. As soon as the stepper motor is against the flange of the induction elbow (20), discontinue the actuation of the control. By tightening the four cylinder screws (8), mount the stepper motor on the induction elbow.

Then screw in the inspection glass (15) with seal into the mixer body (1).

5.8 Adjusting the proximity sensors (limit switches)

Adjust the mixing gap to 0.4 ± 0.05 mm by moving the stepper motor (10) in the “rich” (larger gap) direction. An adjustment of 0.4 mm takes place with a control frequency of 20 Hz in full step operation in 4 seconds.

Note

- With a change to the control frequency by a factor K, the adjusting time changes by the factor $1/K$.
- With a change to the step precision by a factor $1/F$, the adjusting time changes by the factor F.
- With an adjustment of both parameters, factors F and $1/K$ are multiplied.

Adjust the switching point of the “lean” position by screwing in the proximity sensor (13). Screw in the proximity sensor until the LED on the proximity sensor goes out. Then lock the proximity sensor in its position by tightening the counter nut. Observe the tightening torque according to section **6.1 Spare parts drawing**.

If the device is equipped with two proximity sensors, the switching point for the “rich” position is adjusted first (max. mixing gap width). For this purpose, increase the mixing gap an additional 5 mm from the “lean” switching point by moving the stepper motor (total gap width 5.4 ± 0.05 mm). In full step operation the additional adjustment at a 50 Hz step frequency takes place in 20 seconds. Observe the notice above.

The adjustment of the screw-in position of the proximity sensor, “rich” switching point, takes place analogously to the adjustment of the “lean” switching point. Then lock the proximity sensor in place here as well by tightening the counter nut.

6. Spare parts

6.1 Spare parts drawing HON 985B-70/35-ZW-N-NI

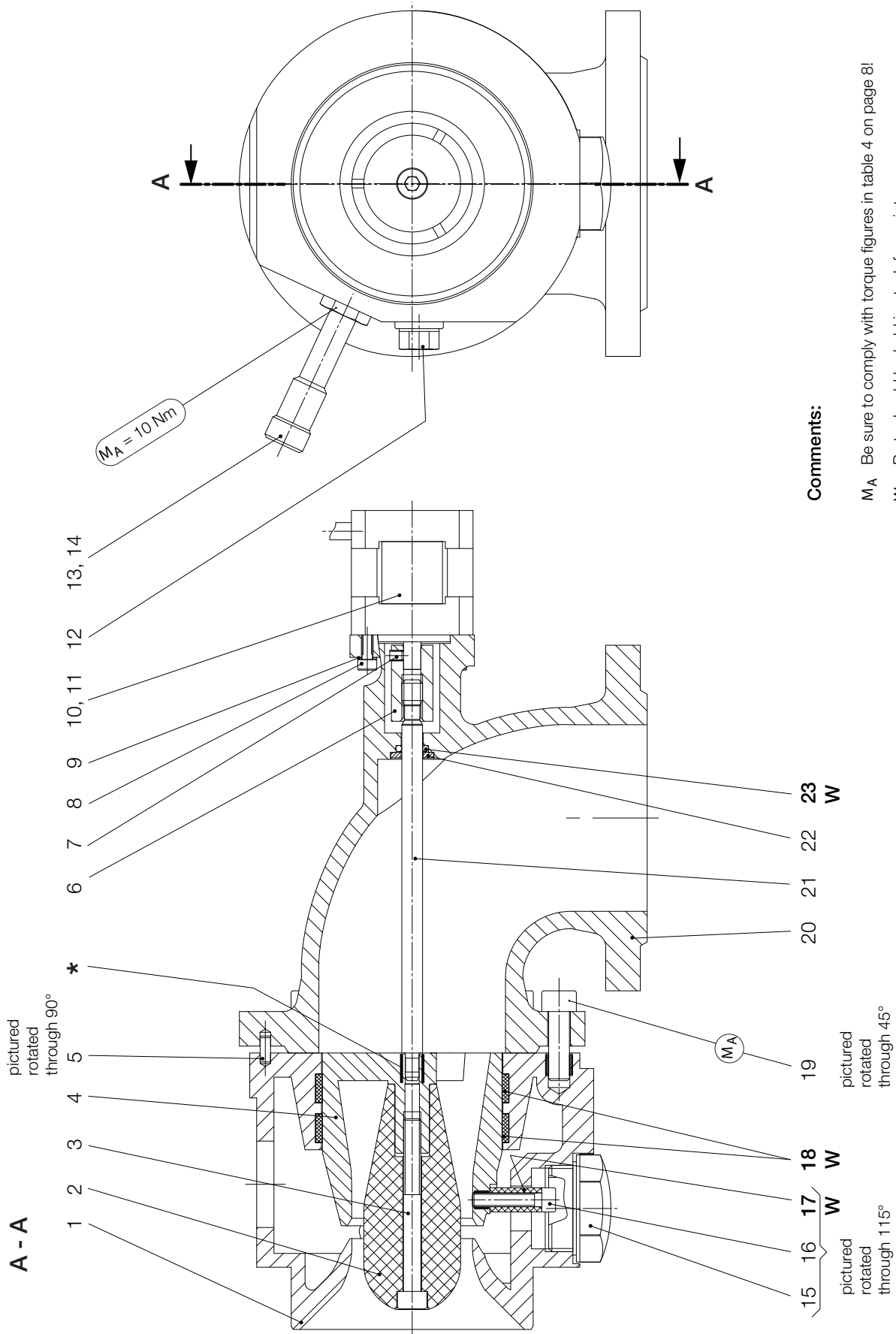

Comments:

M_A Be sure to comply with torque figures in table 4 on page 8!

W Parts should be held in stock for maintenance purposes

★ Use adhesive connection in accordance with table 6, page 8

6.2 Spare parts drawing HON 985B-70/35-ZW-N-NI

Item no.	Denomination	Number	W	Material	Part no.
1	Mixer body	1		GLM	10031360
2	Torpedo, optional:				
2	Torpedo Ø 14	1		LM	10031207
2	Torpedo Ø 19	1		LM	10031181
2	Torpedo Ø 22.5	1		LM	10031478
2	Torpedo Ø 25	1		LM	10031170
2	Torpedo Ø 27	1		LM	10031479
2	Torpedo Ø 28.5	1		LM	10031167
3	Cylinder screw	1		St	10660
4	Venturi insert	1		GLM	10031365
5	Cylinder pin	2		St	17086
6	Adjustable coupling	1		AIBz	10031370
7	Threaded pin	1		St	12405
8	Cylinder screw	4		St	101248
9	Washer	4		St	101249
10	Stepper motor	1		LM/Bz	101242
11	Socket	1		K	24107
12	Locking screw	1		St	27922
13	Proximity sensor	1		NSt	24122
14	Socket	1		K	24123
15	Inspection glass	1		K	101227
16	Cylinder screw	1		St	10602
17	Bush	1	W	K	10031368
18	Guide belt	2	W	K	10031463
19	Cylinder screw	4		St	10591
20	Induction elbow	1		GLM	10031363
21	Pin	1		NSt	10031369
22	Washer	1		St	8279
23	O-Ring	1	W	KG	20226

W Parts should be held in stock for maintenance purposes

German abbreviations stand for the following materials:

St ... Steel	LM ... Light metal	GMs ... Cast brass
NSt ... Stainless steel	Ms ... Brass	GZn ... Cast zinc
FSt ... Spring steel	GS ... Cast steel	AIBz ... Aluminium bronze
NFSt ... Stainless spring steel	GGG ... Spheroidal graphite cast iron	K ... Plastic
Bz ... Bronze	GBz ... Cast bronze	KG ... Gummos synthetic materials
Cu ... Copper	GLM ... Cast light metal	SSt ... Foamed materials

6.3 Parts for maintenance purposes

Item no.	Denomination	Number	Part no.
17	Bush	1	10031368
18	Guide belt	2	10031463
23	O-Ring	1	20226
	Slip agent	1	27704
	Adhesive	1	26690
	Assembly paste	1	27091
	Thread locker	1	26688
	Silicone grease	1	27081

For More Information

To learn more about Honeywell's
Advanced Gas Solutions, visit
www.honeywellprocess.com or contact
your Honeywell account manager

GERMANY**Honeywell Process Solutions**

Honeywell Gas Technologies GmbH

Osterholzstrasse 45

34123 Kassel, Germany

Tel: +49 (0)561 5007-0

Fax: +49 (0)561 5007-107

HON 985.29-3
2017-01
© 2017 Honeywell International Inc.

Honeywell