



## **HON HSV086 SERIES SAFETY SHUT-OFF VALVES**

Efficient, Sustainable and Safe Gas Distribution

# HON HSV086 and HON HSVS086 Series Valves

Designed to offer overpressure and under pressure protection, the HON HSV086 series from Honeywell (former Gortec brand) comprises safety shut-off valves for use in gas transmission systems, gas distribution networks and industrial gas pressure regulating systems. The HON HSV086 series is supported by Honeywell's global expertise and unmatched local support capabilities.



## HON HSV086

Honeywell's HSV086 series consists of a number of effective safety shut-off valves for use in gas transmission systems, gas distribution networks and industrial gas pressure regulating systems.

The HON HSV086 has demonstrated its quality and usability for more than 25 years. The HON HSV086 has been improved and modified according to current technology.

The HON HSV086 series consists of two types of safety shut-off valves:

- HON HSV086, the standard model with nominal diameters of 1"-12"
- HON HSVS086, with a two-stage release mechanism in nominal diameters >16."

Both types offer overpressure and underpressure protection. The HON HSV086 and HON HSVS086 feature modular construction and are supplied with a standard control mechanism and sensing element. Both are suitable for operating pressures up to 100 bar. Nominal diameters up to 12" are available in pressure classes up to ANSI 2500.

## HON HSVS086

In comparison with the standard model, the HON HSVS086 is equipped with a two-stage release mechanism and an extra valve bushing.

The two-stage release mechanism features the option of controlling greater capacities while maintaining accuracy by means of an extra reduction of disturbance forces on the control mechanism. Another advantage is the increase in the maximum closing member lift that uses the same standard control mechanism.

In addition, it is easier to commission and maintain because, in the closed position, the first stage can be activated independently from the second stage, thus making it possible to set the mechanism and carry out fine adjustments without activating the valve body assembly.



## Features

### Low Maintenance Costs

- Long maintenance interval because of:
  - minimal friction
  - minimal number of parts
- Easy to assemble/disassemble:
  - valve body remains in line during maintenance
  - seat ring is easy to inspect
- The use of economical materials

### Modular Construction

- separation between sensing element, control mechanism and valve body assembly
- sensing element(s) and control mechanism(s) are identical for every nominal diameter and pressure class

### Special Patented Valve Seat

- long maintenance interval due to the erosion-free enclosure of the seat ring
- bubble-tight even at low temperatures

### High Degree of Operational Safety

- not sensitive to vibration
- minor dynamic trip mechanism displacement
- single suspension closing member (HON HSV086)
- short safety circuit

### High Reproducibility/Accuracy

- minimal hysteresis

### Emergency Button Closes in Case of

- a break in the sensing line
- diaphragm rupture in combination with minimum pressure shut-off

### Double Construction

- one valve with two control mechanisms, for safeguarding two pressures

### Accessories

- various sensing elements/adjusting springs
- closing by remote control
- position indicator on closing member
- open/close sensors on closing member

### Clear and Complete Technical Documentation

- satisfies current requirements
- available in different languages

# Operation HON HSV086

The HON HSV086 safeguards against exceeding a maximum pressure and falling beneath a minimum pressure. The protection against underpressure serves also as a protection against a diaphragm rupture.

## Protection Against Overpressure

When the pressure to be safeguarded (1) in the sensing element (3) exceeds the maximum value set with the springs (5) and (6), the diaphragm (2) is pushed downwards and turns the lever (8) around the pivot (9). The pin (7) is pushed upwards, turning the balance (10) to the right side around the pivot (11).

This results in the downward aimed switch pin (18) eventually stops being supported by the balance (10), causing the switch lever (16) to turn on its shaft. This shaft (17) is the supporting point for the closing member with closing member stem (20). When the switch lever (16) has rotated a 90° turn, the closing member (20) closes due to the closing spring (19) located in the valve body.

In the closed position, the pressure behind the closing member will be reduced to the outlet pressure. The pressure difference between inlet and outlet pressure provides an additional closing force to the closing member (20). The safety device is now locked. The closing member will also remain shut even if the safeguarded pressure (1) drops below the maximum value.

## Protection Against Underpressure

When the safeguarded pressure (1) in the sensing element (3) is lower than the trip value set with the spring (6), the diaphragm (2) shifts upwards.

Using its spring cup (4), the top part of the adjusting spring (5) comes to rest against the housing of the control mechanism and no longer against the diaphragm (2), causing the pressure for switching to be determined by the spring (6) alone.

The lever (8) will now push the pin (12) downwards, causing the balance (10) to rotate to the right, just as when maximum pressure is exceeded. The actions of the switch lever (16) and the closing member (20) are similar to those when maximum pressure is exceeded.

The closing member shuts in the same way in the event of a diaphragm rupture.

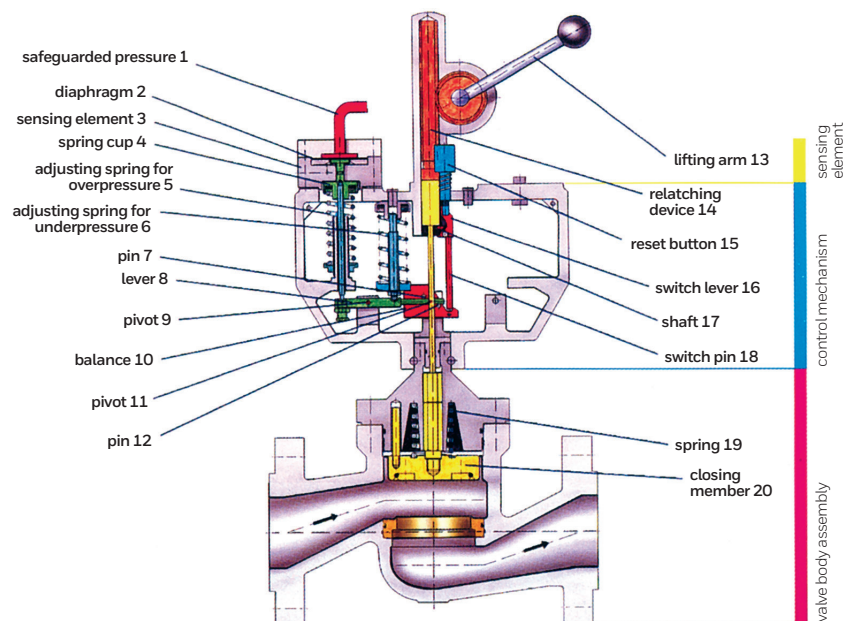

## Unlocking

After correcting the failure or malfunction and a pressure equalization across the closing member (20), the mechanism can only be opened manually. This is accomplished by pushing down the lifting arm (13), turning it to the right and simultaneously pushing the reset button (15). After the mechanism has been opened, a spring pushes the lifting arm back into starting position and the relatching device (14) is disengaged.

The release operation for the first stage is identical to that of the HON HSV086. The difference is the release of a second stage. If the standard control mechanism (8) releases, the lever (10) will rotate to the right around the pivot (4). A rotation of approximately  $15^\circ$  causes the closing member stem (5) to no longer be supported by shaft (2), causing the closing member (6) to shut. The closing member and the closing member stem are pushed into the seat ring by gravity and by the closing spring (11).

Unlocking the second stage after correcting the failure or malfunction and the pressure equalisation across the closing member, occurs after unlocking the standard control mechanism (8). The valve (6) is easy to open, using the hand wheel (1).

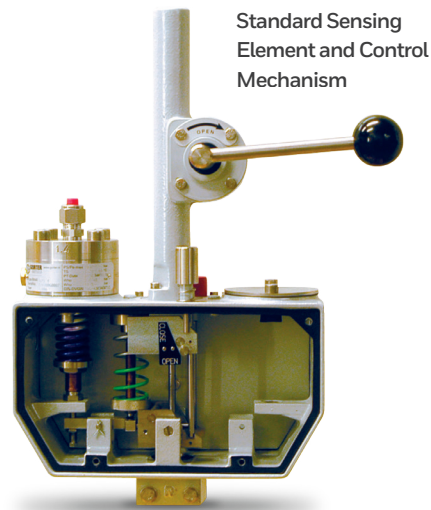

## Operating Scheme HON HSVS086

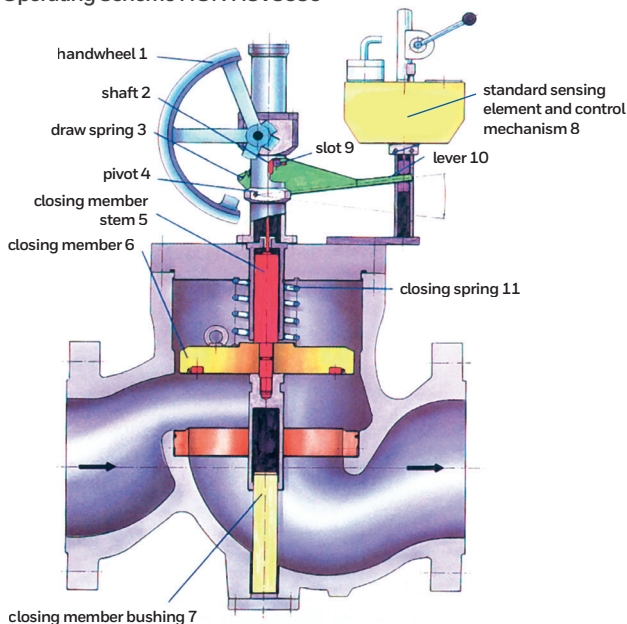

## Technical Specifications

General	
Type Indication	HON HSV086 (nominal sizes 1-12") HON HSVS086 (nominal sizes >16")
Pressure Class	ANSI 300 and ANSI 600 (**)
Maximum Pressure	50 bar ANSI 300, 100 bar ANSI 600
Operating Temperature	-20°C to +60°C (***)
Ambient Temperature	-30°C to +60°C (***)
Set Range for Overpressure	3-49.5 bar ANSI 300, 3-95 bar ANSI 600 (*)
Set Range for Underpressure	0.7-10 bar (*)

(\*) Higher set range for underpressure or overpressure protection upon request.

(\*\*) Other pressure classes up to ANSI 2500 are available.

(\*\*\*) Other temperature ranges on request

Flow Coefficient HON HSV086	
Nominal Size (inches/mm)	Cg Value
1"/25	480
2"/50	1,950
3"/80	4,300
4"/100	7,050
6"/150	15,100
8"/200	26,060
10"/250	40,800
12"/300	60,050
16"/400	95,300
20"/500	156,000

Flow coefficient HON HSVS086 upon request.

Classification Acc. DIN 3381/EN 14382	
Accuracy Group	AG 1: 20-95 bar
Overpressure Protection	AG 2.5: 3-21 bar
Underpressure Protection	AG 5: 0.7-10 bar (*)
4"/100	7,050

(\*) Note: All pressures listed in table are overpressures.

HON HSV086 Measurements (mm) and Weights (kg)						
Nominal Size		ANSI 300		ANSI 600		ANSI 300/600
Inches	mm	L	Weight	L	Weight	H
1"	26	203	30	216	30	619.5
2"	50	267	45	292	51	626
3"	80	318	70	356	80	661
4"	100	356	105	432	115	671
6"	150	444	195	559	210	726
8"	200	559	295	660	320	863
10"	250	787	690	787	760	963
12"	300	838	870	838	930	959
16"	400	990	1180	990	1290	1372
20"	500	1397	2310	1397	2460	1340

Measurements and weights for HON HSVS086 upon request.

Material Specifications (Standard)	
Part	Material
Valve Body	A352-LCC(QT) or Equal • 1"/DN25: S355 or Equal
Bonnet Flange	S355 or A352 or Equal
Valve Plug	S355 or Equal
Valve Plug Stem	SS
Seat Ring	SS
Control Mechanism	SS
Diaphragm	NBR with Nylon Reinforcement
Dynamic O-rings	Viton
Static O-rings	NBR
Sensing Element	S355 or Equal

Special materials upon request.

## Capacity Calculation

The following formulas can be used to approximate pressure losses of the slam shut valve with the valve plug in open position.

$$\Delta p = \frac{Q_n^2 \cdot d \cdot (T_e + 273)}{(13,94 \cdot C_g)^2 \cdot P_e}$$

$\Delta p$  = pressure loss in bar

$Q_n$  = capacity in  $m^3/h$

$P_e$  = inlet pressure in bar

$C_g$  = flow efficient

$d$  = relative density (air=1)

$T_e$  = temperature of the gas at the inlet of the safety valve

$\dot{U}_n$  = density of the gas in normal conditions  
(with  $T=273$  Kelvin)

For natural gas with  $\rho_n = 0.83 \text{ kg/m}^3$

$$d = 0.643$$

For gasses other than natural gas

$$d = \rho_n \text{ gas} / 1.29$$

$$Q_{\max} \leq K D \sqrt{P_e \min}$$

with  $D$  = nominal size (in mm)

$P_e \min$  = minimal inlet pressure in bar absolute

$Q_{\max}$  = maximum flow rate in  $m^3/h$

$K = 100$  for DN = 1" up to 6"

$K = 100$  for DN = 8" up to 12"

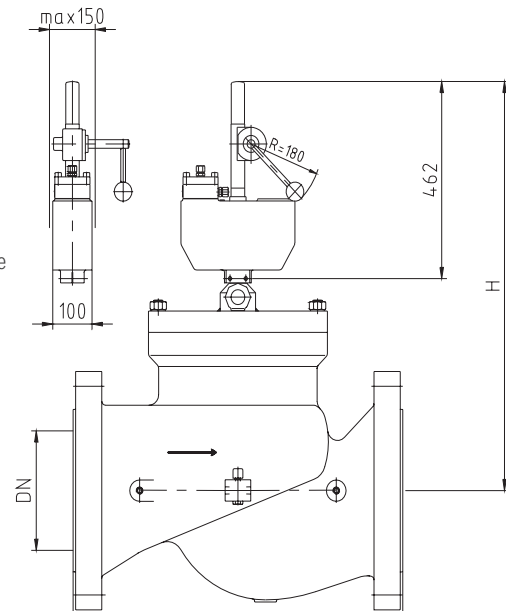

Dimensional sketch HON HSV086

**For more information**

To learn more about Honeywell's  
Advanced Gas Solutions, visit  
[www.honeywellprocess.com](http://www.honeywellprocess.com) or contact  
your Honeywell account manager.

**Honeywell Process Solutions**

Honeywell Gas Technologies GmbH  
Osterholzstrasse 45  
34123 Kassel, Germany  
Tel: +49 (0)561 5007-0  
Fax: +49 (0)561 5007-107  
[www.honeywellprocess.com](http://www.honeywellprocess.com)

BR-17-73-ENG | 12/22  
©2022 Honeywell International Inc.

**Honeywell**  
THE POWER OF **CONNECTED**